

| REV. | MODIFICATION.      | DATE     | DRN |
|------|--------------------|----------|-----|
| 01   | PRODUCTION RELEASE | 23/02/12 | SF  |
| 02   | 2011249            | 27/03/12 | NB  |

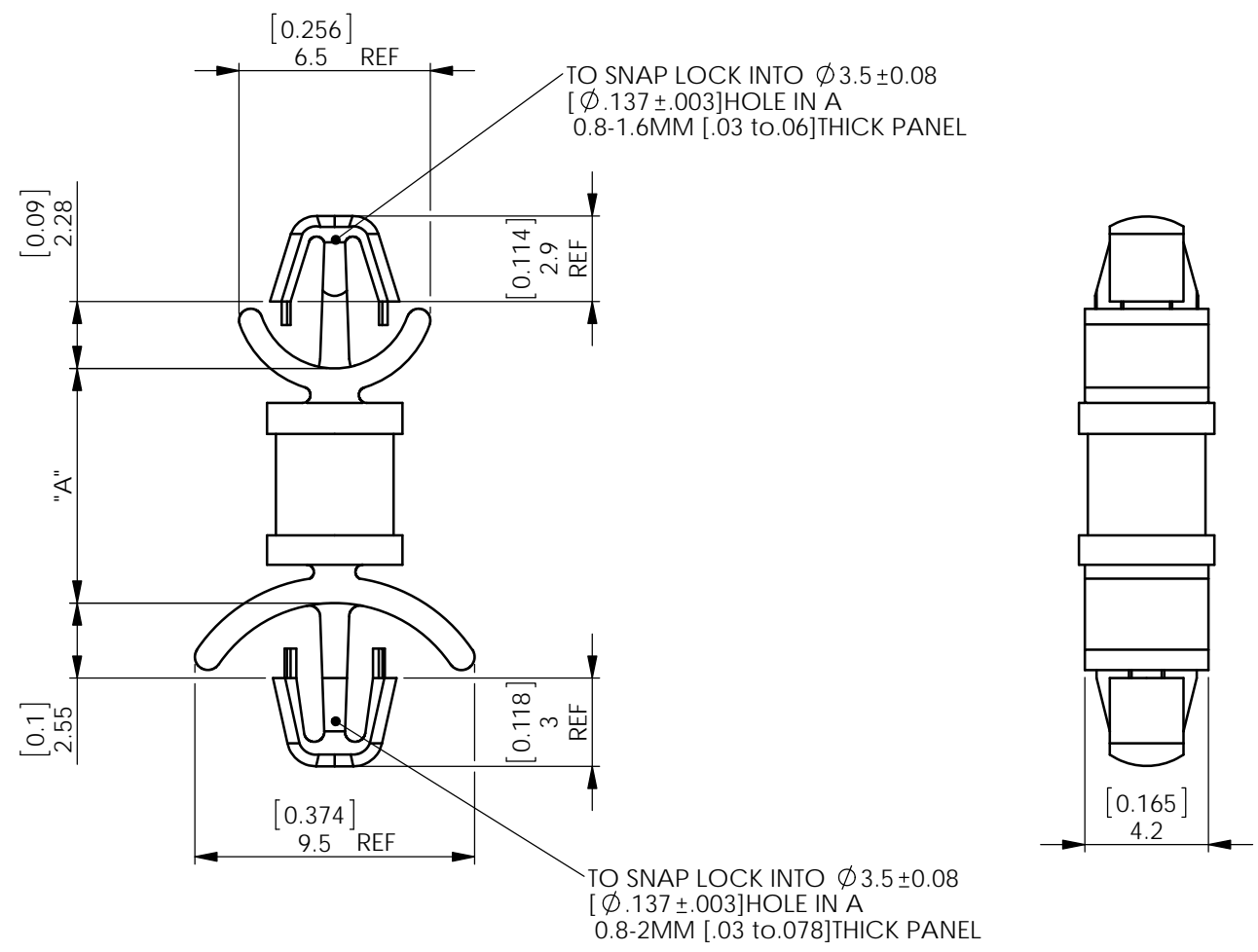
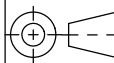

ALTERNATE UNITS FOR REFERENCE ONLY

INFORMATION CONTAINED IN THIS DOCUMENT IS CONFIDENTIAL TO RICHCO INTERNATIONAL Co. Ltd. AND MAY NOT BE DISCLOSED OR REPRODUCED IN WHOLE OR PART WITHOUT THEIR WRITTEN CONSENT.

|   |   |   |
|---|---|---|
| <b>RICHCO, INC.</b><br>WWW.RICHCO-INC.COM | ALL DIMENSIONS IN mm<br>GENERAL TOLERANCES ±0.25<br>UNLESS OTHERWISE STATED<br>1 DECIMAL PLACE ±<br>2 DECIMAL PLACES ±<br>ANGULAR ±1° | THIRD<br>ANGLE<br> |
|   | MATERIAL:<br>SEE TABLE  |   |

| NYLON 6/6 UL94 V-2 (RMS-01)                              | NYLON 6/6 UL94 V-0 (RMS-19) | "A" STANDOFF HEIGHT ±0.4 |
|--|-----------------------------|--------------------------|
| DLCBS8-3-01  | DLCBS8-3-19                 | 4.8[.19]                 |
| DLCBS8-4-01  | DLCBS8-4-19                 | 6.4[.25]                 |
| DLCBS8-5-01  | DLCBS8-5-19                 | 7.9[.31]                 |
| DLCBS8-6-01  | DLCBS8-6-19                 | 9.5[.37]                 |
| DLCBS8-7-01  | DLCBS8-7-19                 | 11.1[.44]                |
| DLCBS8-8-01  | DLCBS8-8-19                 | 12.7[.50]                |
| DLCBS8-9-01  | DLCBS8-9-19                 | 14.3[.56]                |
| DLCBS8-10-01   | DLCBS8-10-19                | 15.9[.63]                |
| COLOUR:NATURAL(OTHER COLOURS AVAILABLE BY SPECIAL ORDER) |                             |                          |

|  |                            |                                     |                         |
|--|----------------------------|-------------------------------------|-------------------------|
| DESCRIPTION: <b>DUAL LOCKING CIRCUIT BOARD SUPPORT</b> |                            | COLOUR:<br>SEE TABLE                |                         |
| DRG No:<br><b>012-015</b>                              |                            | PROJECT NUMBER:<br><b>EU11-0036</b> |                         |
| PART No:<br>SEE TABLE                                  |                            | SHEET SIZE <b>A4</b>                |                         |
| DRN<br><b>SF</b>                                       | DATE<br><b>23/02/12</b>    | CHKD<br><b>TC</b>                   | DATE<br><b>23/02/12</b> |
| SCALE<br><b>NTS</b>                                    | SHEET No.<br><b>1 OF 1</b> |                                     |                         |