

REV.	MODIFICATION.	DATE	DRN
01	PRODUCTION RELEASE	22/02/12	RA

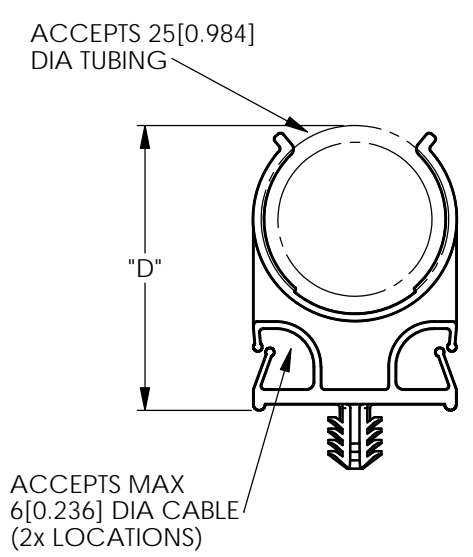
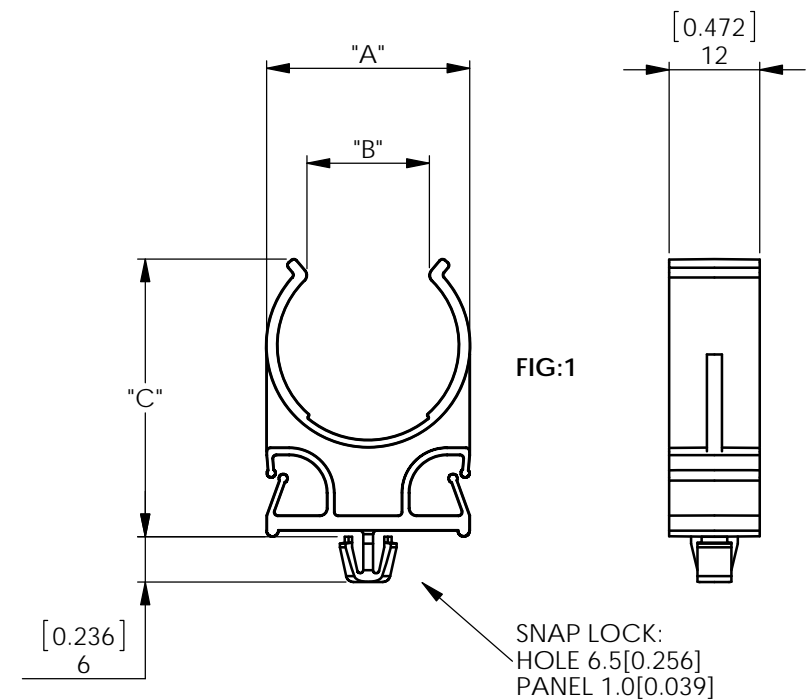
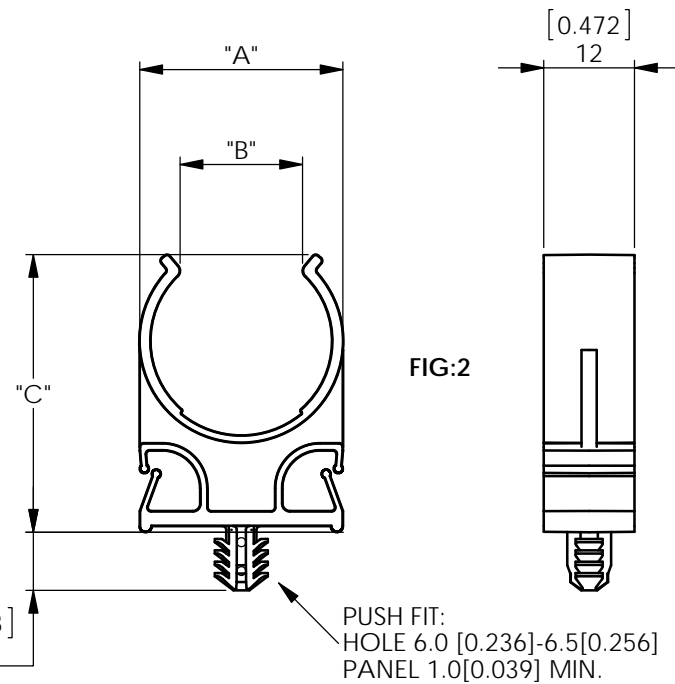

NOTE:
ALTERNATE UNITS FOR REFERENCE ONLY

INFORMATION CONTAINED IN THIS DOCUMENT IS CONFIDENTIAL TO RICHCO INTERNATIONAL Co. Ltd. AND MAY NOT BE DISCLOSED OR REPRODUCED IN WHOLE OR PART WITHOUT THEIR WRITTEN CONSENT.

PART No.	FIG	"A" REF	"B" REF	"C" REF	"D" REF
PDC-1-01	1	27 [1.06]	16 [0.64]	36.7 [1.45]	37.7 [1.484]
PDCBH-1-01	2				

RICHCO, INC. WWW.RICHCO-INC.COM		ALL DIMENSIONS IN mm GENERAL TOLERANCES ±0.25 UNLESS OTHERWISE STATED 1 DECIMAL PLACE ±0.25 2 DECIMAL PLACES ± 0.10 ANGULAR ±1°		THIRD ANGLE
MATERIAL: NYLON 6/6 UL94-V2(RMS-01)			COLOUR: NATURAL	
DESCRIPTION: PIPE AND DUAL CABLE CLIP			PART No: SEE TABLE	
DRG No: 012-026		PROJECT NUMBER: EU12-0016		Mass:(g) 3.2
DRN RA		DATE 22/03/12		CHKD TC
		DATE 23/03/12		SCALE NTS
			SHEET SIZE A4	SHEET No. 1 OF 1