

REV.	MODIFICATION.	DATE	DRN
01	C02010267	24/09/08	SF
02	C02010794	28/08/09	PH

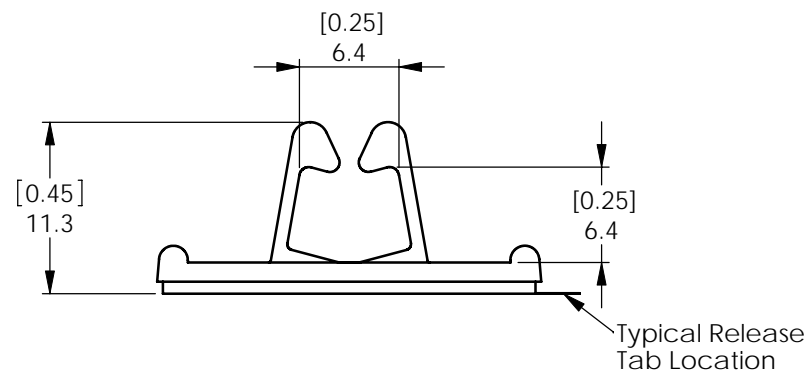
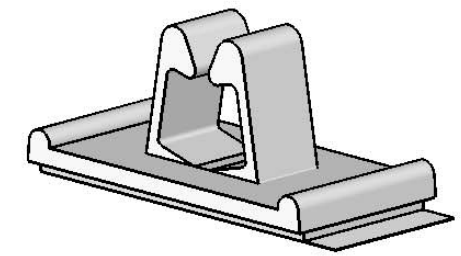
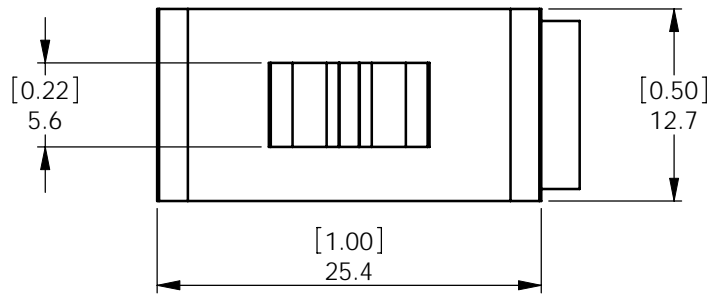

ALTERNATE UNITS FOR REFERENCE ONLY

INFORMATION CONTAINED IN THIS DOCUMENT IS CONFIDENTIAL TO RICHCO INTERNATIONAL Co. Ltd. AND MAY NOT BE DISCLOSED OR REPRODUCED IN WHOLE OR PART WITHOUT THEIR WRITTEN CONSENT.

RICHCO, INC.
WWW.RICHCO-INC.COM

ALL DIMENSIONS IN mm
GENERAL TOLERANCES ± 0.25
UNLESS OTHERWISE STATED
1 DECIMAL PLACE \pm
2 DECIMAL PLACES \pm
ANGULAR $\pm 1^\circ$

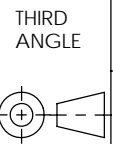

- NOTES:
 1. ALSO AVAILABLE IN NYLON 6/6 UL94 V-0 BY SPECIAL ORDER. TO ORDER REPLACE SUFFIX "01" WITH "19".
 2. ALSO AVAILABLE WITHOUT ADHESIVE BY SPECIAL ORDER. TO ORDER REMOVE SUFFIX "A4-RT".
 3. TAPE-1.0(0.04) THICK DOUBLE SIDED ACRYLIC ADHESIVE (RMS-324).

MATERIAL: Nylon 6/6 UL94 V-2 (RMS-01)		COLOUR: Natural	
DESCRIPTION: Wire Clip On Base		PART No: WCB-250-01A4-RT	
DRG No: 08-096	NPR No: XXXX-XXX	SHEET SIZE A4	
DRN SF	DATE 24/09/08	CHKD TC	DATE 24/09/08
SCALE NTS	SHEET No. 1 OF 1		