

REV.	MODIFICATION.	DATE	DRN
A	PROPOSAL DRAWING	08/11/04	TC
X	XXXXXX	XX/XX/XX	XXX
X	XXXXXX	XX/XX/XX	XXX

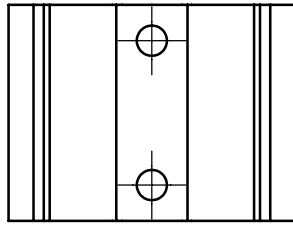

APPLY DOUBLE SIDED ADHESIVE TAPE IN 2 PLACES AS SHOWN

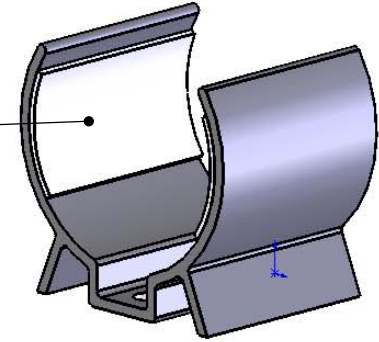

NOTES:

- 1) STANDARD PACK QUANTITY: 1000.
- 2) ALL DIMENSIONS IN mm.

R17.45 Ref

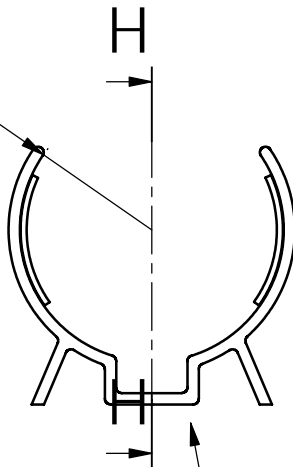

28.6

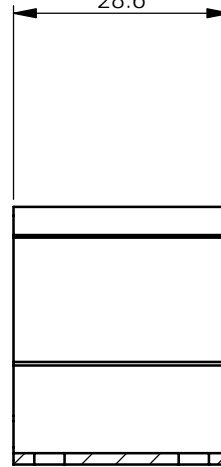

SECTION H-H

EXISTING CATALOGUE ITEM PART No V-1011

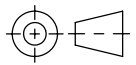
INFORMATION CONTAINED IN THIS DOCUMENT IS CONFIDENTIAL TO RICHCO INTERNATIONAL Co. Ltd. AND MAY NOT BE DISCLOSED OR REPRODUCED IN WHOLE OR PART WITHOUT THEIR WRITTEN CONSENT					
			GENERAL TOLERANCES ± 0.25 UNLESS OTHERWISE STATED 1 DECIMAL PLACE \pm 2 DECIMAL PLACES \pm ANGULAR $\pm 1^\circ$		
MATERIAL: EXISTING V-1011 - RMS-04 ADHESIVE TAPE - RMS-15A				COLOUR: Part - Black Tape - White	
TITLE: V-1011 With Adhesive Tape				PART No: XXXX-XXX	
DRG No: XXXX-XXX		NPR REF: 2004-352		 SIZE A4	
DRN TC	DATE 08/11/04	CHKD XXX	DATE XX/XX/XX	SCALE NTS	SHEET No 1 OF 1