

Generation 2 CAN Bus Keypads

Key Features

- Modern Flush Styling
- No-tool Snap-in Front Mounting
- LEDs on Ridges for Greater Viewing Angle
- Designed for ISO 13849 Safety Rated Vehicles
- Self-Diagnostics Include:
 - Supply Voltage Monitoring
 - Indicator “LED ON” Verification
 - Button Short Detection
- Low current sleep mode (<1.5 mA) with wake on:
 - CAN message
 - Button Press
 - Input Pin Signal
- CAN FD Tolerant
- 2 Configurable I/O Pins
- Dimmable LED indicators and legends
- Same Field-tested Reliability as Our Original Keypads - Over 1 Million in Operation



- Backward Compatible Firmware with Existing 3K Keypads

Custom Options

- Custom button top legends
- Up to 3 LED indicators per button

Ordering Information

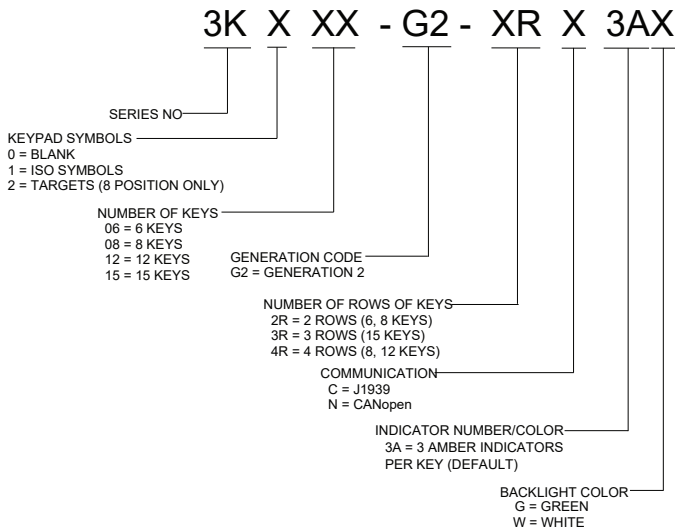

Indicator colors:

- Amber (Standard)
- Blue
- Green
- Red
- White
- Yellow

Backlight colors:

- Green (Standard)
- White (Standard)
- Amber
- Blue
- Pure Green
- Red
- Yellow

MIX & MATCH with Any Keypad and Symbol Form Factors Number of Keys

BLANK VERSIONS SHOWN

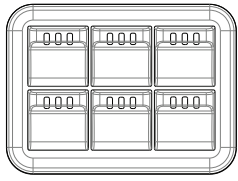

6 POSITION KEYPAD

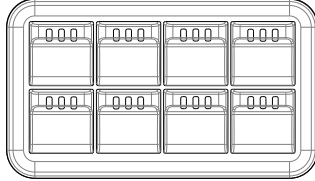

8 POSITION KEYPAD (HORIZONTAL)

ISO SYMBOLS

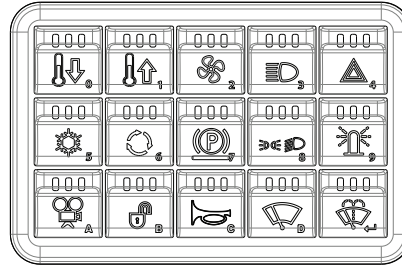

15 POSITION KEYPAD

TARGET LEGENDS SHOWN

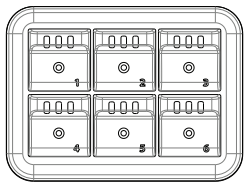

6 POSITION KEYPAD

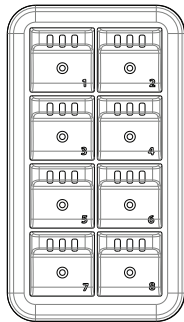

8 POSITION KEYPAD (VERTICAL)

CONNECTOR PINOUT

MATES WITH DEUTSCH #DT06-6S WITH W6S WEDGE LOCK.

PIN	SIGNAL
1	POWER
2	GROUND
3	I/O 1
4	I/O 2
5	CAN_H
6	CAN_L

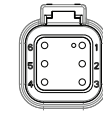

8, 12, 15 BUTTON KEYPAD CONNECTOR

MATES WITH DEUTSCH #DT06-4S WITH W6S WEDGE LOCK.

PIN	SIGNAL
1	POWER
2	GROUND
3	CAN_H
4	CAN_L



6 BUTTON KEYPAD CONNECTOR

Flexible I/O pins can be configured as

- Relay Driver
- 10mA Constant Current Push-Pull

DIMENSIONS in inches (and millimeters)

6 POSITION KEYPAD
3KX06-G2-2RX3AX

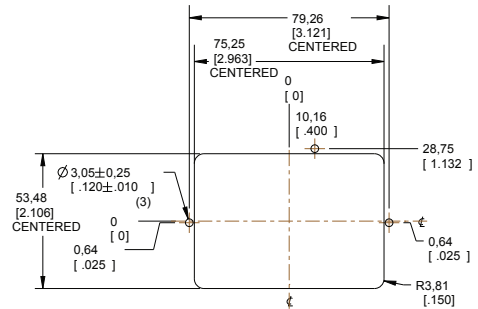
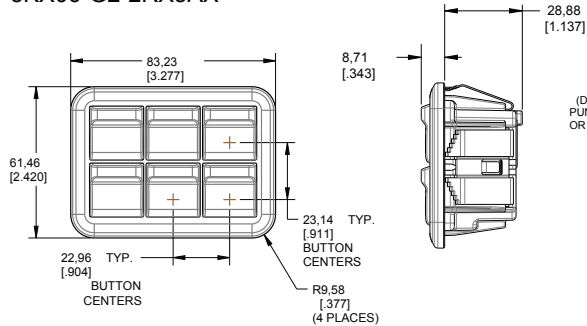

PANEL CUTOUT AND MOUNTING INFORMATION

ALL DIMENSIONS ARE ± 0.50mm
(PANEL THICKNESS TO BE 2.5 ± 1.0mm)

8 POSITION KEYPAD (HORIZONTAL)
3KX08-G2-2RX3AX

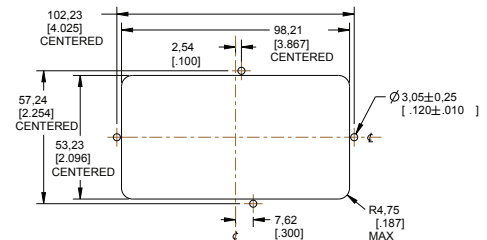
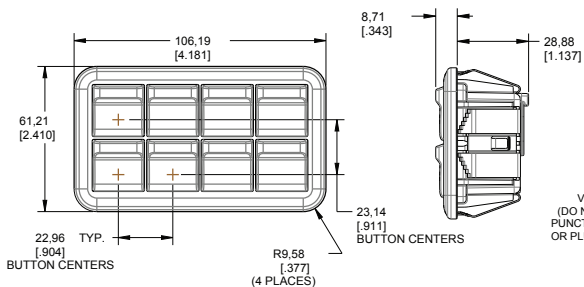

PANEL CUTOUT AND MOUNTING INFORMATION

ALL DIMENSIONS ARE ± 0.50mm
(PANEL THICKNESS TO BE 2.5 ± 1.0mm)

DIMENSIONS in inches (and millimeters)

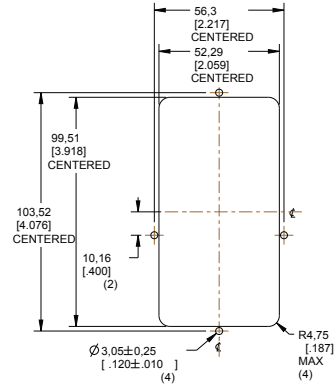
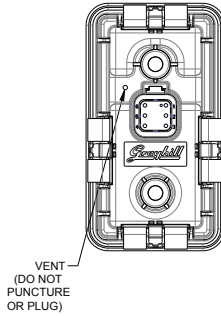
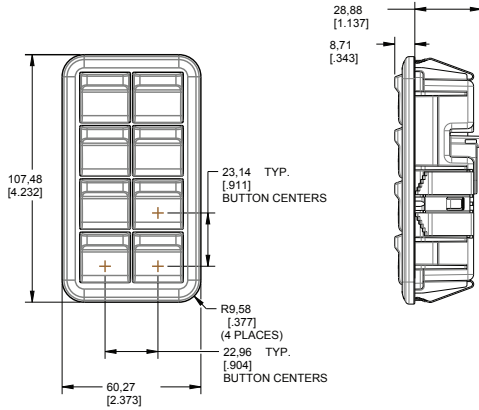
**8 POSITION KEYPAD
(VERTICAL)
3KX08-G2-4RX3AX**

PANEL CUTOUT AND MOUNTING INFORMATION
ALL DIMENSIONS ARE $\pm 0.50\text{mm}$
(PANEL THICKNESS TO BE $2.5 \pm 1.0\text{mm}$)

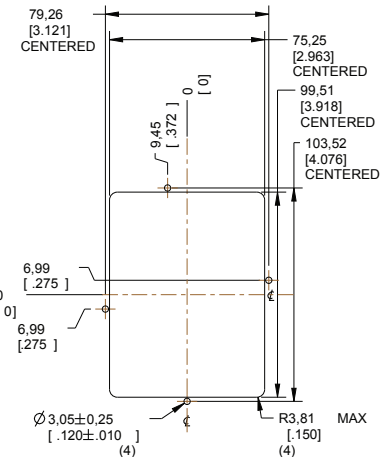
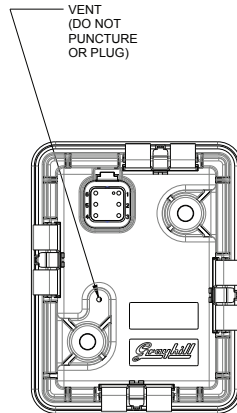
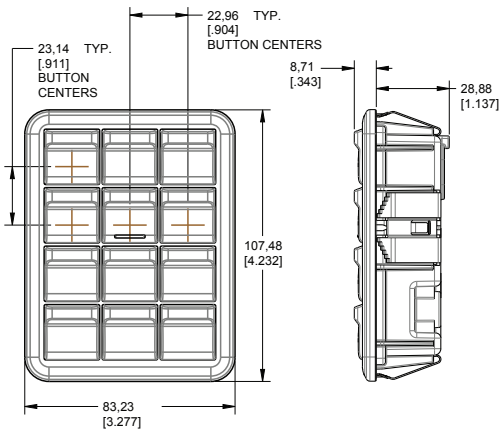
**12 POSITION KEYPAD
3KX12-G2-4RX3AX**

PANEL CUTOUT AND MOUNTING INFORMATION
ALL DIMENSIONS ARE $\pm 0.50\text{mm}$
(PANEL THICKNESS TO BE $2.5 \pm 1.0\text{mm}$)

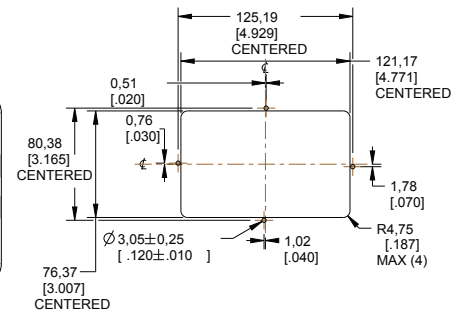
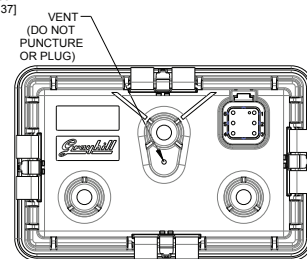
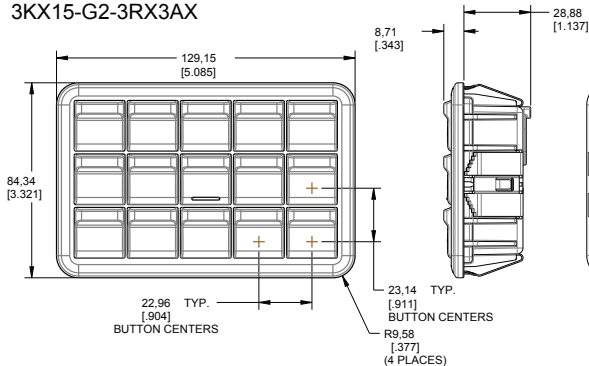
**15 POSITION KEYPAD
3KX15-G2-3RX3AX**

PANEL CUTOUT AND MOUNTING INFORMATION
ALL DIMENSIONS ARE $\pm 0.50\text{mm}$
(PANEL THICKNESS TO BE $2.5 \pm 1.0\text{mm}$)

ELECTRICAL SPECIFICATIONS

Maximum Load	ISO 16750-4 5.1	Low Temp = -40C, High Temp = +85C Duration: 4 hours at Low Temp, 11 hours at High Temp Maximum load applied
Over-voltage	ISO 16750-2 4.3.2	High Voltage: 36V, Duration: 60 min Tmax - 20°C
Superimposed alternating voltage	ISO 16750-2 4.4	Severity 2 and 3 Ri = 50mΩ Frequency Range: 50Hz to 25kHz Sweep Duration: 120s Number of sweeps: 5 (continuously)
Slow decrease and increase of supply voltage	ISO 16750-2 4.5	
Momentary drop in supply voltage	ISO 16750-2 4.6.1	Class B No Reset
Reset behavior at voltage drop	ISO 16750-2 4.6.2	Class C
Starting Profile	ISO 16750-2 Sec. 4.6.3 Formerly known as pulse 4	12V, Level II Class B and Level IV Class A 24V, Level II Class A and Level III Class A
Load Dump	ISO16750-2 sec 4.6.4.2.2 Test A Formerly known as ISO7637-2 pulse 5	12V: Us = 101V, 12V case Ri = 4 ohm, td=400ms 24V: Us = 202V, 24V case Ri = 8 ohm, td=350ms
Reverse Polarity	ISO 16750-2 4.7.2.3	Voltage: -28V, Duration: 60s
Open Circuit tests	ISO 16750-2 4.9.1.2	Relay and signal outputs to be connected to load
Short-circuit Protection	ISO 16750-2 4.10.2 Signal Circuits	Connect all signal inputs and outputs to Vmax and GND for 60s. One circuit tested at a time.
Short-circuit Protection	ISO 16750-2 4.10.3 for load circuits	ISO 8820 operating time rating +10% Minimum Class C
Parallel inductive load	ISO7637-2 Pulse 1	Us = -600V
Wire Harness Inductance	ISO 7637-2 Pulse 2a	Wire Harness Inductance
Switching Spikes	ISO 7637-2 Pulse 3a	Pulse 3a: Us = -300V Pulse 3b: Us = +300V
Fast transients mutual coupling	ISO 7637-2 Pulse 3b	Pulse a: 24V class IV Us = -80 Pulse b: 24V class IV Us = +80
Slow transients mutual coupling	ISO7637-3 4.3.2	DCC Slow + = +30 DCC Slow - = -30 ICC slow + = +6 ICC slow - = -6

PHYSICAL SPECIFICATIONS

Vibration, Random	ISO 16750-3 4.1.2.7	Commercial vehicle, Sprung Masses
Vibration, Sinusoidal	MIL-STD-202G, Method 204D, Test Condition C	Logarithmic Sweep from 10 Hz - 2000 Hz - 10 Hz over a period of 20 minutes Duration: 4 hours duration (12 cycles) in each of 3 orthogonal axes. Maximum displacement for 10Hz - 55Hz: 0.06". Peak acceleration for 55Hz - 2000 Hz: 5G.
Shock/Crash Safety	ISO 16750-3 4.2.2	Pulse shape: half-sinusoidal Acceleration: 500 m/s ² Duration: 6 ms Number of shocks: 10 per test direction.
Drop	ISO 16750-3 4.3	Height: 400 mm Repeat for all practical edges and faces
Chemical Resistance	ISO 16750-5	All agents on Table 1 except Battery Fluid

ENVIRONMENTAL SPECIFICATIONS

Operating temperature	ISO 16750-4 5.1.1.2 ISO 16750-4 5.1.2.2	Low temperature -40°C for 24hrs High temperature +85°C for 96hrs
Storage Temperature	ISO 16750-4 5.1.1.1 ISO 16750-4 5.1.2.1	Low temperature -55°C High temperature +105°C
Thermal Shock	ISO 16750-4 5.4.3	High temperature +85 °C Water temperature: 2±2 ° C
Altitude (Barometric Pressure)	IEC60068-2-13	Sea level to 15240m (101.3 kPa to 11.6 kPa), Exposure Time: 2 hours
Shipping Integrity	ISTA procedure 3A	
Solar Radiation	ISO 4892-2 Method B 1000 hours SAE J2527 1000 hours	No change in color or appearance of protective hardcoat layer.
Ingress Protection (IP6K7/9K)	IIEC 60529 - IP6KX/IPX9K ISO 20653 8.3.3 - IPX7	
Humidity	ISO 16750-4 5.7 (Damp Heat) ISO 16750-4 5.6.2.2 (Humidity Cycling)	Damp Heat: Duration: 21 days Temperature: 40 ° C Humidity: 85% Humidity Cycling: Test Db, Variant 1. Thigh = 55 ° C Number of cycles: 6 Duration of cycle: 24 hours
Salt Fog	ISO 16750-4 5.5.1	5% aqueous solution of NaCl @ 35°C and a pH between 6.5 and 7.2
Extended Duration temperature and humidity cycling	Custom temperature/humidity profile	Temperature Cycle: Dwell at -40 ° C for 15 minutes Ramp to 85 ° C over 45 minutes Dwell at 85 ° C for 15 minutes Ramp to -40 ° C over 45 minutes Humidity Cycle: 70% when temperature is 85 ° C Humidity uncontrolled while temperature < 0 ° C during ramp-up and during ramp-down. Voltage cycle: 12VDC from the beginning of the temperature ramp-up to the beginning of the temperature ramp-down OVDC everywhere else Total number of cycles: 343 (620 hours / 29 days total)

ELECTROMAGNETIC COMPATIBILITY SPECIFICATIONS

Radiated Immunity	ISO 11452-2 ALSE	80 MHz - 1000 MHz, 200V/m
	ISO 11452-2 ALSE	1000 - 2500 MHz, 200V/m, 3-axis
	ISO 11452-3 TEM cell	0.01 - 200 MHz, 300V/m
	ISO 11452-4 Bulk current injection	0.5 MHz - 400MHz, 300mA
	ISO 11452-5 150 mm Stripline	0.01 MHz - 400MHz, 300V/m
Electrostatic Discharge	ISO 10605 8 powered-up test	ESD Capacitor Network 330pF, 330Ω Conductive Surfaces Contact Discharge +/-15kV Non-Conductive Surfaces Air Discharge +/-25kV Indirect Discharge +/-20kV
Electrostatic Discharge	ISO 10605 9 unpowered test	ESD Capacitor Network 150pF / 2kΩ Conductive Surfaces Contact Discharge +/-15kV Non-Conductive Surfaces Air Discharge +/-25kV Indirect Discharge +/-20kV
Radiated Emissions Broadband	ISO14982 CISPR 25 where frequency bands are specified	CISPR 25 Class 5 where specified CLASS 3 - Average, Peak and Quasi Peak (where specified), on remaining CISPR 25 defined bands
Radiated Emissions Narrowband	ISO14982 CISPR 25 where frequency bands are specified	CISPR 25 Class 5 where specified CLASS 3 - Average, Peak and Quasi Peak (where specified), on remaining CISPR 25 defined bands
Conducted Emissions	CISPR 25 6.2	Class 5