

# Measurement and Sensor Systems with conception

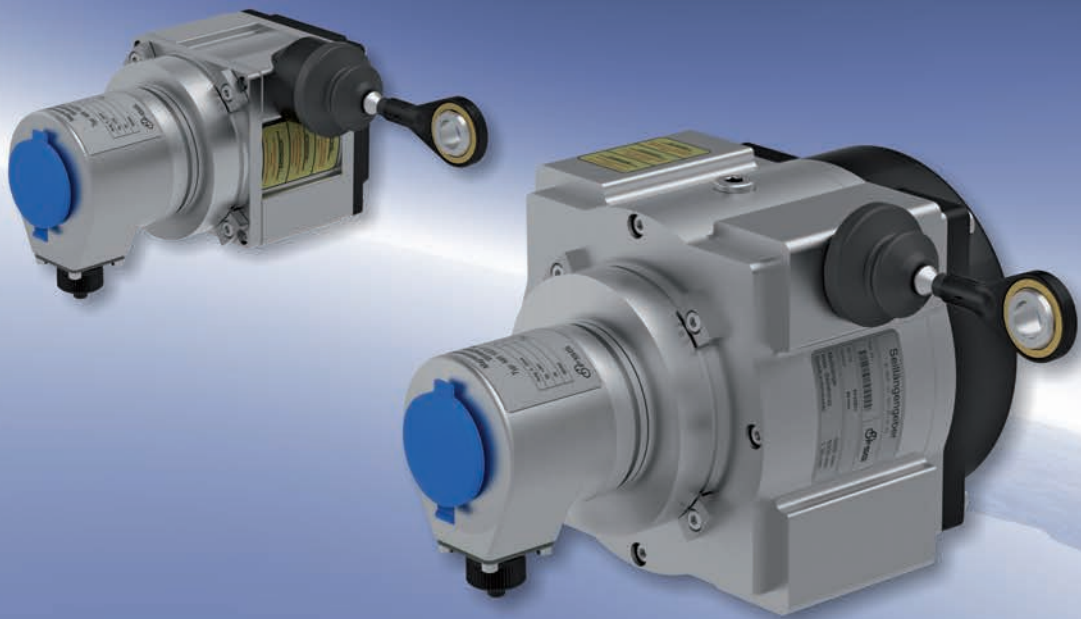

Rope Length Transmitter



# Rope Length Transmitter

Rope Length Transmitters were used for length and speed measurements of linear movement operations in several applications. Particularly they are easy to mount and have flexible designs.

Besides a number of customized solutions we have three standard designs which can be used in different applications for length measurements.

All three designs contain in a flat plastic or robust aluminium casing a low-mass high-precise measuring drum with extremely solid spring-return. The winding of the robust high-flexible steel rope will be on one layer.

All standard designs have a flange, coupling or gear adaptation and were suitable for adaptation of an own encoder systems or for customary in trade encoder systems.

## Application range

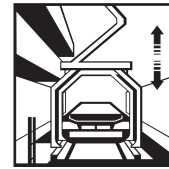

## Measuring systems

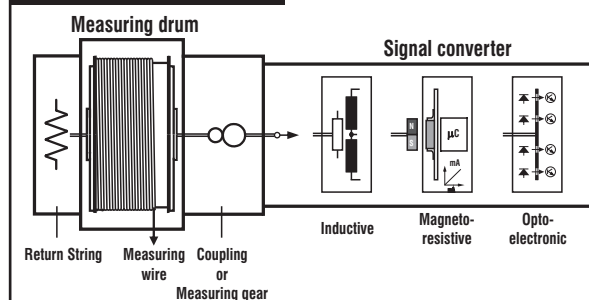

# Series

## Series SL00



### Low-cost versions for measuring ranges up to max. 5.000 mm

- flat design
- light-weight plastic design
- drum bearing carried out by the shaft of the flanged encoder
- various mounting possibilities
- possibility to attach all encoding systems customary in trade with servo mount sizes 13 and 23

## Series SLO

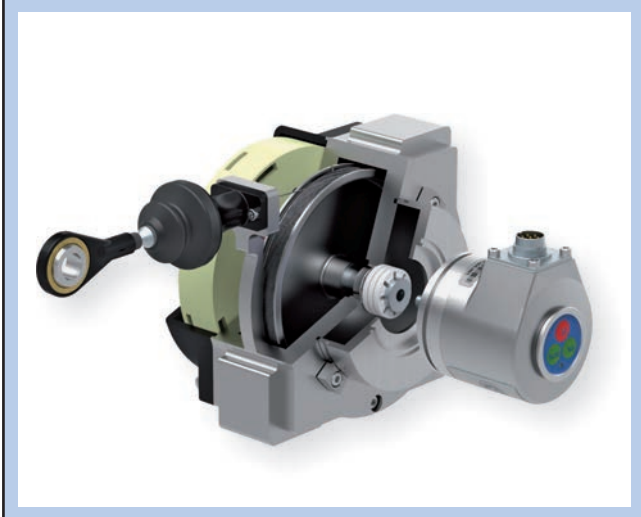

### Low-priced metal design for measuring ranges up to max. 15.000 mm

- robust drum casing, material: aluminium
- low-priced option to SL-series
- possibility to attach all encoding systems customary in trade with servo mount sizes 13 and 23 via backlash compensated coupling or backlash compensated gearing
- axial fixed wire drum with forced winding of measuring wire

## Series SL



### Robust, industrial version for large measuring length up to max. 60.000 mm

- patented drum drive with regard to wire withdrawal via threaded spindle
- advanced working reliability and measuring accuracy
- robust drum casing, material: aluminium
- possibility to attach all encoding systems customary in trade with servo mount sizes 13 and 23 by means of backlash compensated coupling or backlash compensated gearing
- flexible mounting of all accessory parts possible

# Rope Length Transmitter of series SL00

## Characteristics of series SL00

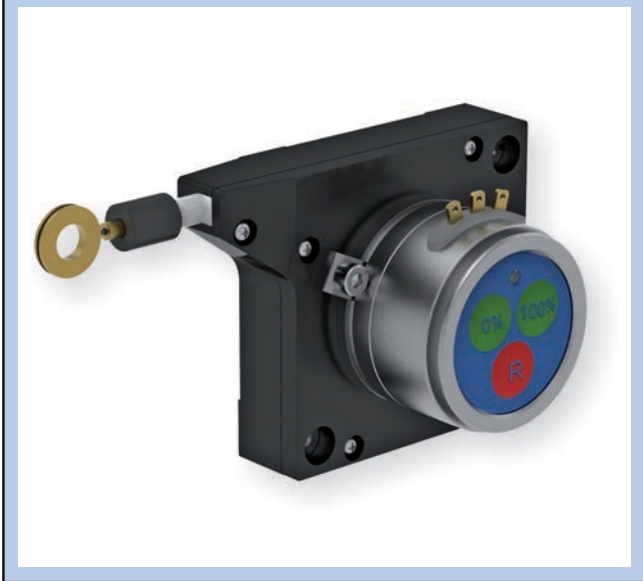

- measuring length up to 5.000 mm
- low-cost version
- flat design
- light-weight plastic design
- manifold fastening possibilities
- drum bearing will be carried out by shaft of flanged encoder, encoder is available in potentiometric, magnetic or optic system
- possibility to attach all encoding systems customary in trade
- with stainless-steel measuring wire
- measuring drum made of aluminium with forced winding of measuring wire

Technical data	SL00 125 GS 55	SL00 1250 GS 55	SL00 200 GS 80	SL00 3000 GS 80	SL00 350 GS 130	SL00 5000 GS 130
Measuring length up to	0,125 m	1,25 m	0,2 m	3 m	0,35 m	5 m
Casing material	plastic, Noryl					
Circumference of drum (incl. wire)	150 mm	150 mm	230 mm	230 mm	385 mm	385 mm
Measuring wire Ø	0,81 mm	0,45 mm	0,81 mm	0,55 mm	0,81 mm	0,55 mm
Material of measuring wire	1.4401					
Linearity *	± 0,01 %					
Reproducibility	0,005 %					
Hysteresis	0,1 %					
Speed adjustment	8 m / s	6 m / s	8 m / s	6 m / s	4 m / s	3 m / s
Spring return strength	1,4 N	1 - 1,4 N	6,3 N	5 - 6,3 N	7 N	4,5 - 7 N
Life cycle (typical) **	up to 1 million complete reversal cycle					
Temperature range	– 30° C up to +70° C					
IP code	IP 50					
Weight (without encoder)	80 g	80 g	250 g	250 g	800 g	800 g

Please see for technical data of FSG encoder the chart on page 10.

\* referring to measuring value of Rope Length Mechanic without encoder system

\*\* The life cycle is dependent to the type of load. Factors of influence are: environmental conditions, mounting conditions, used measuring range, traverse speed as well as acceleration.

SL00 / GS 55

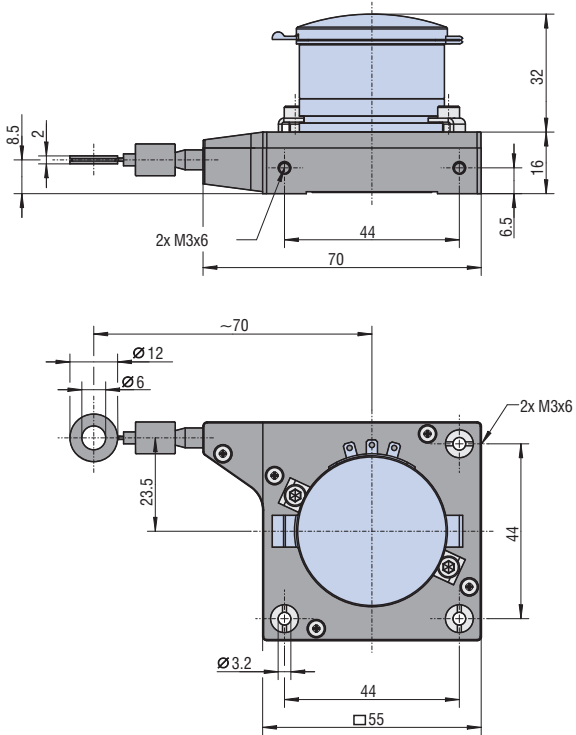

SL00 / GS 80

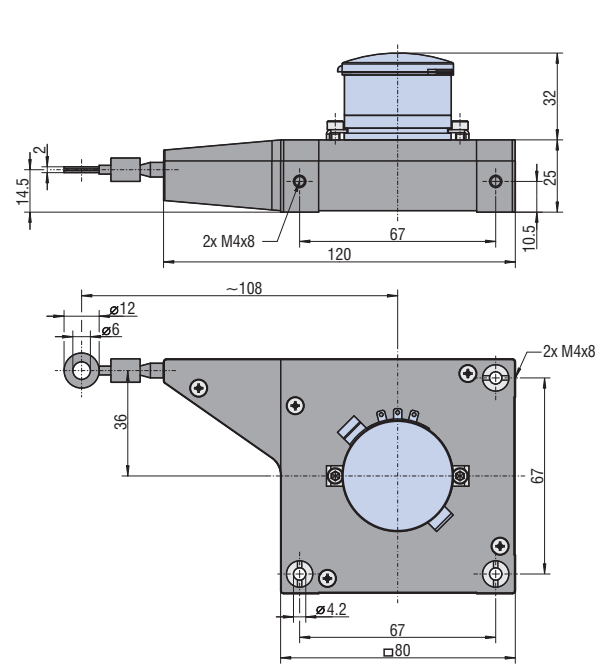

SL00 / GS 130

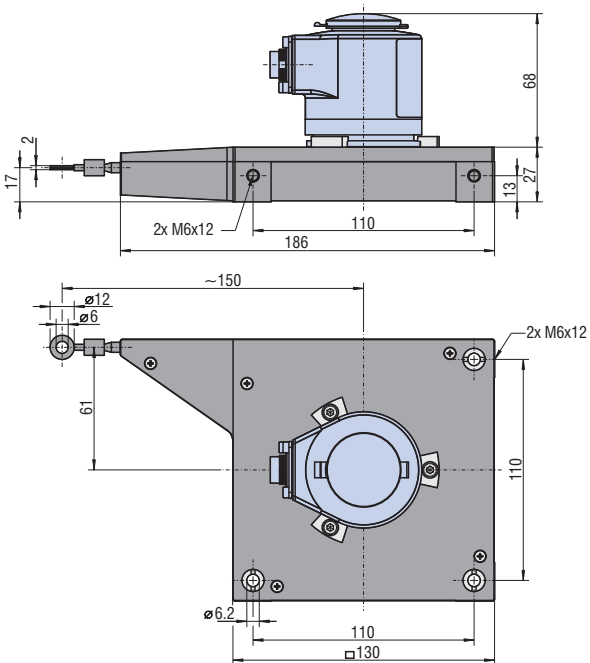

# Rope Length Transmitter of series SLO

## Characteristics of series SLO



- measuring length up to 5.000 mm
- in special design max. measuring length up to 15.000 mm possible
- robust drum casing, material: aluminium
- low-priced option to SL-series
- forced winding of measuring wire on axial fixed anodised aluminium drum will be made via an upstream inlet point which is secured by a bellow

Technical data	SLO 1 GS 55	SLO 2...3 GS 80		SLO 5 GS 130
Measuring length up to	1,25 m	2 m	3 m	5 m
Casing material	aluminium, anodized			
Circumference of drum (incl. wire)	125 mm	200 mm	200 mm	333,3 mm
Measuring wire Ø	0,55 mm			
Material of measuring wire	1.4401			
Linearity *	± 0,1 %			
Reproducibility *	0,1 %			
Hysteresis *	0,1 %			
Speed adjustment	8 m / s			
Spring-return strength	4 - 6 N	5 - 15 N		15 - 20 N
Life cycle (typical) **	up to 1 million complete reversal cycle			
Temperature range	– 30° C up to +70° C			
IP code	IP 64			
Weight (without encoder)	0,5 kg	1 kg	1,1 kg	2 kg
<b>Dimensions (in mm)</b>				
A	32	35	45	59
B	47	58	68	86

Please see for technical data of FSG encoder the chart on page 10.

\* referring to measuring value of Rope Length Mechanic without encoder system

\*\* The life cycle is dependent to the type of load. Factors of influence are: environmental conditions, mounting conditions, used measuring range, traverse speed as well as acceleration.

SLO / GS 55

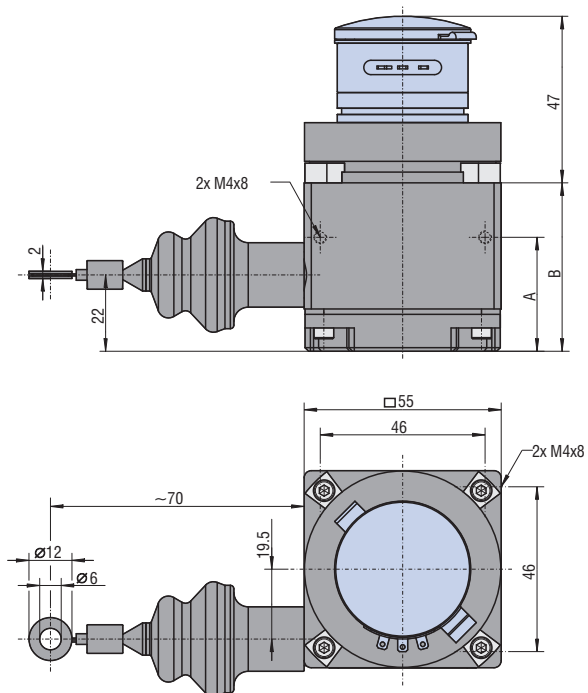

SLO / GS 80

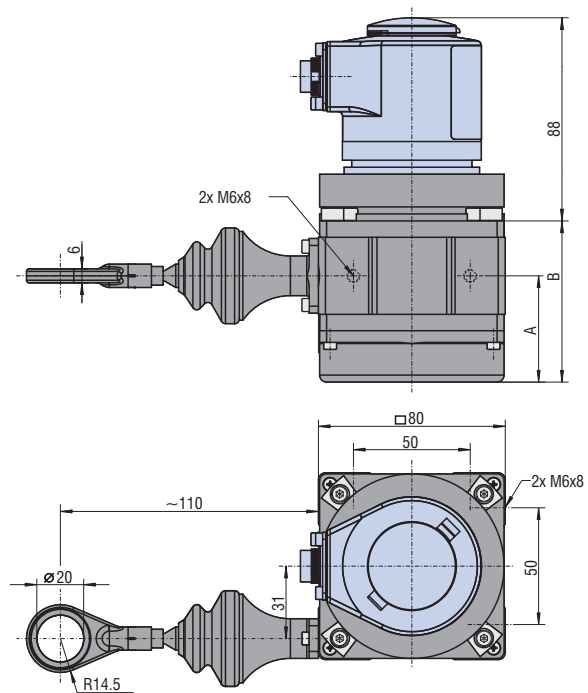

SLO / GS 130

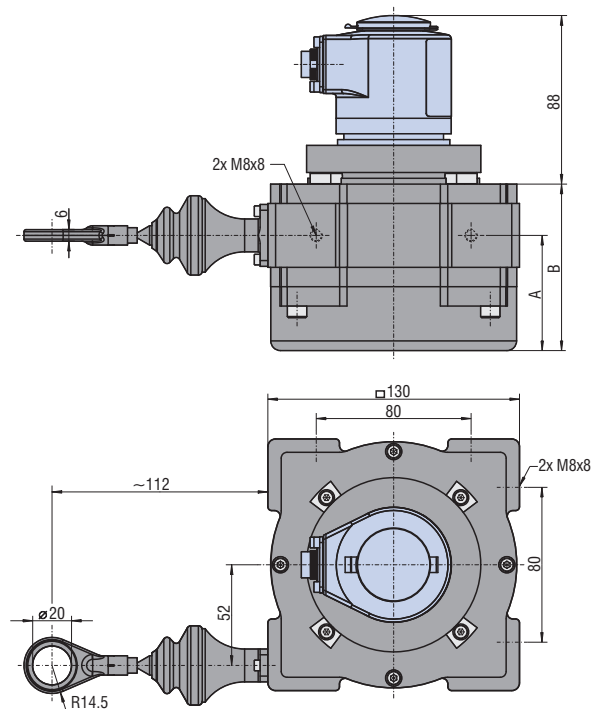

# Rope Length Transmitter of series SL

## Characteristics of series SL



- measuring length up to 60.000 mm
- patented wire drum mechanic:  
A high-flexible measuring wire, made of rust- and acid-proofed stainless steel, will be wound on a precise measuring drum which will be powered by a spiral spring. During this winding operation, the measuring drum will be staggered via a threaded spindle in axial direction, so that the measuring wire will be wound parallel always in a constant pitch.
- robust drum casing, material: aluminium
- high reliability and accuracy of measurement
- possibility to mount all accessories to improve the use; guide pulley, compressed air attachment etc.
- possibility to attach all encoding systems customary in trade
- Ex-approval available 

Technical data	SL 3002 GS 55		SL 3001...3003 GS 80				SL 3005...3030 GS 130						SL 3030...3060 GS 190				
	2 m	1 m	2 m	3 m	5 m	10 m	15 m	20 m	25 m	30 m	30 m	35 m	40 m	50 m	60 m		
Measuring length up to	2 m	1 m	2 m	3 m	5 m	10 m	15 m	20 m	25 m	30 m	30 m	35 m	40 m	50 m	60 m		
Casing material	aluminium, anodized																
Circumference of drum (incl. wire)	125 mm	200 mm			334,1 mm / 332,4 mm ***						491,5 mm						
Measuring wire Ø	0,55 mm	1,35 mm			1,35 mm / 0,81 mm ***						1,35 mm						
Material of measuring wire	1.4401																
Linearity *	± 0,1 %																
Reproducibility *	0,1 %																
Hysteresis *	0,05 %																
Speed adjustment	8 m / s	8 m / s			8 m / s	6 m / s	3 m / s			4 m / s							
Spring-return strength	4 - 8 N	5 - 15 N			10 - 21 N						18 - 37 N						
Life cycle (typical) **	up to 1 million complete reversal cycle																
Temperature range	– 30° C up to +70° C																
IP code	IP 64																
Weight (without encoder)	0,6 kg	0,9 kg	1,1 kg	1,5 kg	2,5 kg	3,5 kg	5 kg	6 kg	7,5 kg	8,5 kg	14,2 kg	16 kg	20 kg	14,5 kg	15,5 kg		
<b>Dimensions (in mm)</b>																	
A ***	45	34	42	60	77	100	147	169	216	238	173	188	203	195	210		
B ***	65	57	72	98	122	167	236	281	350	395	285	315	346	292	322		

Please see for technical data of FSG encoder the chart on page 10.

\* referring to measuring value of Rope Length Mechanic without encoder system

\*\* The life cycle is dependent to the type of load. Factors of influence are: environmental conditions, mounting conditions, used measuring range, traverse speed as well as acceleration.

\*\*\* While using a measuring wire with Ø 0.81 mm the model is shortened.



SL / GS 55

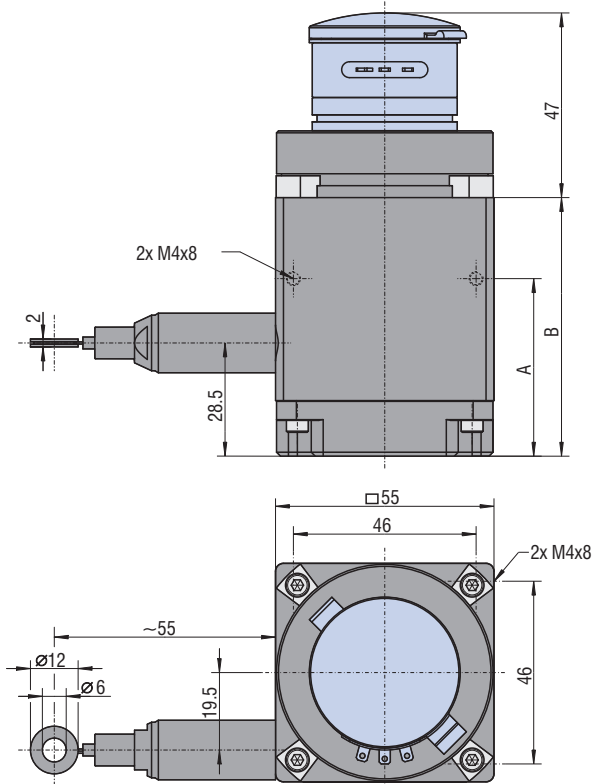

SL / GS 80

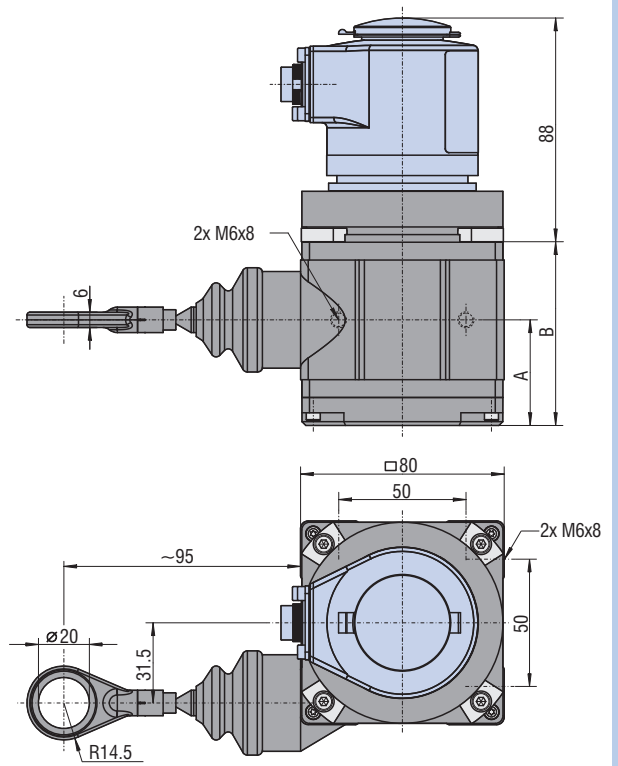



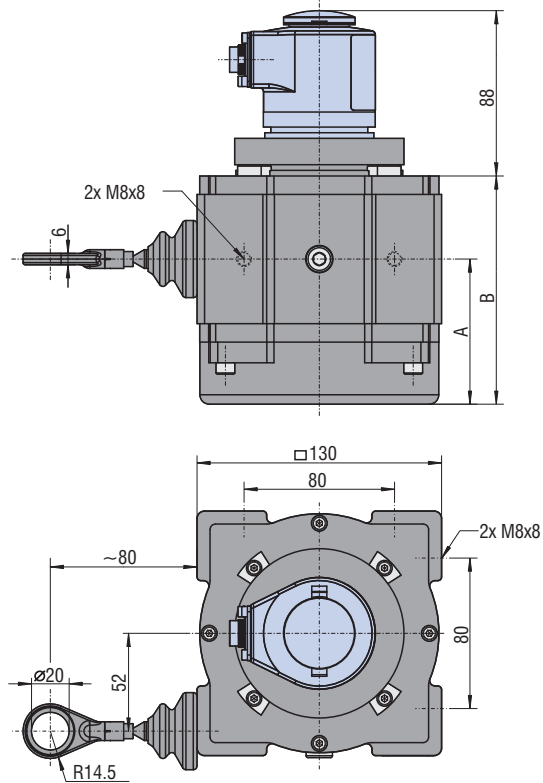

SL / GS 130

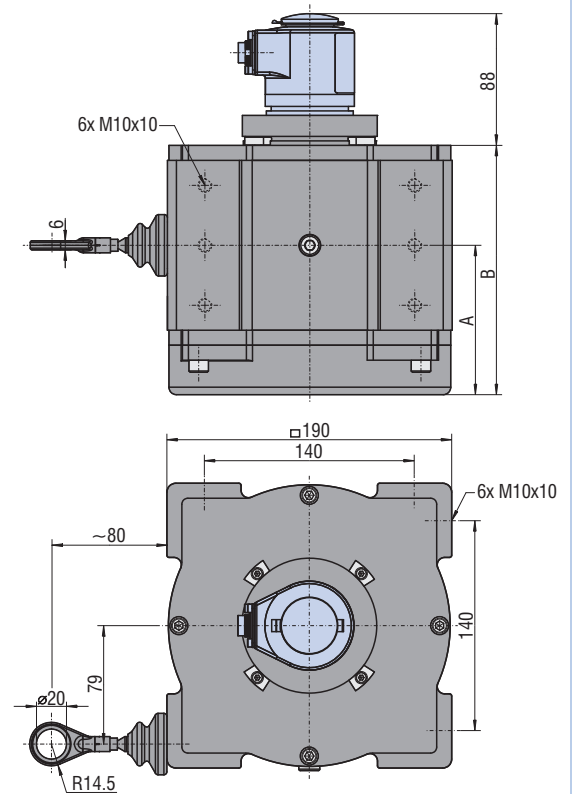

SL / GS 190



# Characteristics of FSG-encoders

Systems	Potentiometric systems				Magnetic systems			
Models								
Type	PK 613		PK 1023		MH 613		MH 1023	
Singleturn / Multiturn	singleturn	multiturn	singleturn		singleturn	multiturn	singleturn	multiturn
Servo size	13		23		13		23	
Casing Ø	36,5 mm		60 mm		36,5 mm		60 mm	
Shaft Ø	6 mm		6 / 10 mm		6 mm		6 / 10 mm	
Rotary angle max.	352°	5632°	355°		360°	5760°	360°	23040°
Rotation max.	1	16	1		1	16	1	64
Voltage output	–		0 - 10 V		0 - 10 V		0 - 10 V	
Current output	–		4 - 20 mA		4 - 20 mA		4 - 20 mA	
R-output	1, 2, 5, 10 kΩ		1, 2, 5, 10 kΩ		–		–	
Bus output	–		–		–		CAN / CANopen	
Redundant electronic	–		1, 2, 5, 10 kΩ		–		4 - 20 mA / CAN	
Signal trim via	–		trimmer		buttons		buttons or CAN-Bus	
Linearity	± 0,2 %		± 0,2 %		± 0,3 %		± 0,2 %	
Resolution	∞		∞		12 bit	16 bit	14 bit	
Supply	–		18 - 33 V DC		18 - 33 V DC		18 - 33 V DC	
Current input	–		< 80 mA		< 80 mA		< 80 mA	
IP code up to	IP 40		IP 65		IP 65		IP 65	
Gender	strand / faston		plug / cable		solder connection / cable		plug / cable	
Weight	100 g		400 g		100 g		400 g	
<b>SL00</b>	GS 55	<input checked="" type="checkbox"/>		<input checked="" type="checkbox"/>	<input checked="" type="checkbox"/>			<input checked="" type="checkbox"/>
	GS 80	<input checked="" type="checkbox"/>		<input checked="" type="checkbox"/>	<input checked="" type="checkbox"/>			<input checked="" type="checkbox"/>
	GS 130			<input checked="" type="checkbox"/>				<input checked="" type="checkbox"/>
<b>SLO</b>	GS 55	<input checked="" type="checkbox"/>		<input checked="" type="checkbox"/>	<input checked="" type="checkbox"/>			<input checked="" type="checkbox"/>
	GS 80			<input checked="" type="checkbox"/>				<input checked="" type="checkbox"/>
	GS 130			<input checked="" type="checkbox"/>				<input checked="" type="checkbox"/>
<b>SL 3000</b>	GS 55	<input checked="" type="checkbox"/>		<input checked="" type="checkbox"/>	<input checked="" type="checkbox"/>			<input checked="" type="checkbox"/>
	GS 80			<input checked="" type="checkbox"/>				<input checked="" type="checkbox"/>
	GS 130			<input checked="" type="checkbox"/>				<input checked="" type="checkbox"/>
	GS 190			<input checked="" type="checkbox"/>				<input checked="" type="checkbox"/>

The complete assortment of encoder types can be found in FSG catalogue Precision Rotary Transducer.

General data	
Casing material	aluminium, anodised, partly coated, special version: salt-water proofed hart-coated
Temperature range	– 30°C up to +80°C, different ranges on request
Testing voltage	500 V, 50 Hz, 1 min
EMC	EN 50 082-2 / EN 50 081-1
Shock / Vibration	50 g, 6 ms / 4 g Sinus 5 - 100 Hz
Current output	$R_L \leq 600\Omega$ 3-wire system, 2- and 4-wire systems on request
Voltage output	$R_L \geq 10\text{ k}\Omega$ 4-wire system
Supply voltage	18 - 33 V DC, different supplies on request

# Mounting of Encoders

The signal output of length measurement is carried out via an mounted single or multiturn encoder. For a length measurement with more than one drum rotation the mounting of the singleturn encoder is carried out via a gear. For the adaptation of the multiturn encoder a multitude of couplings for the different shaft diameters are available.

## Gear

For this purpose a modular build-up is available, which allows reductions of 1 : 2 up to 1 : 128. Also it is free of backlash and suitable for encoders customary in trade of **servo sizes 13 and 23**.

### Gear shifting

1 : 2	1 : 4	1 : 8	1 : 16	1 : 32	1 : 64	1 : 128
-------	-------	-------	--------	--------	--------	---------

Operating mode: The high-precision fit arranged cog wheels will be free of backlash by a feathered primary shaft combination. For this purpose a primary cog wheel as well as a feather unit, which is under tension, will be mounted on the shaft of the encoder.

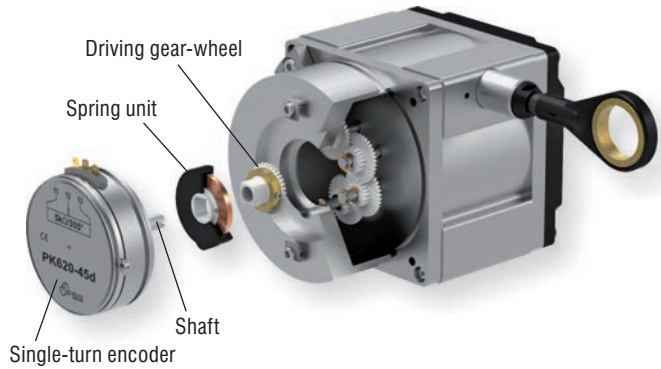

## Coupling

The available plastic couplings allow connections of every encoder system customary in trade without any problem. By default all encoder systems with **servo size 13 and 23** with shaft diameter of 6 mm, 10 mm and 12 mm can be adapted free of backlash.

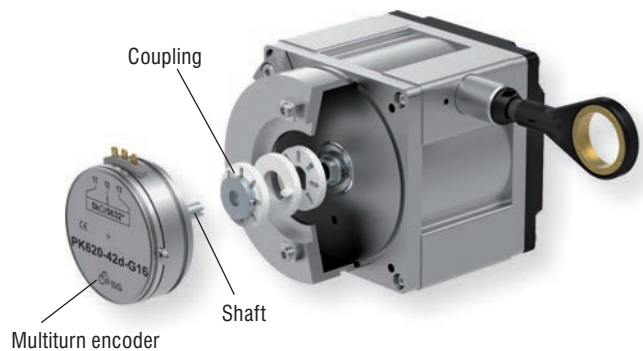

## Easy signal adjustment

The encoders are factory-provided with a nominal length of 4 - 20 mA aligned. Signal adjustments by different length can be made via press buttons.

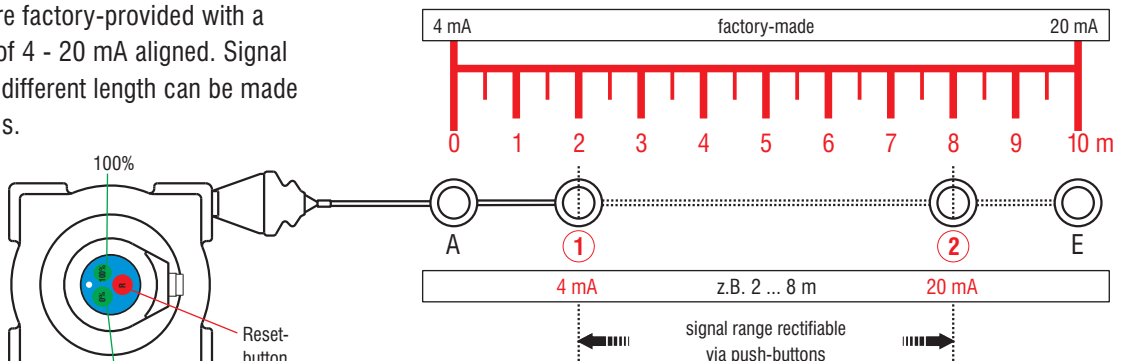

# Accessories

With the extensive accessories, almost every length measuring requirement can be solved – also under most difficult application and environmental conditions. Couplings and measuring gears with adapter flange are designable for all encoder systems customary in trade.

## Wire hooks



**Wire hooks**  
for several fastening possibilities



**Ball joint**  
avoid the break off of the measuring wire

## Attachments



**Wire outlet**  
with bellowed steel head as ice and water wiper

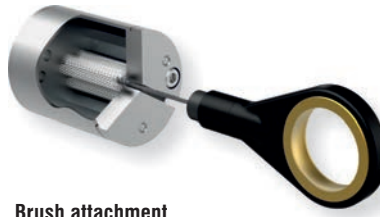

**Brush attachment**  
for extremely dusty and scaled environmental conditions



**Compressed air attachment**  
attachment to avoid dust and dirt entry

## Guide pulley



**Guide pulley**  
for straight wire withdrawal to wire hook



**Double guide pulley**  
for measuring objects with direction change of wire withdrawal



EC-prototype test certificate (optional)  
TÜV 03 ATEX 7131 X Ex II 2G cT5

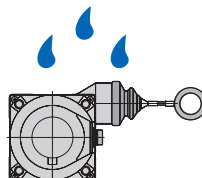

**Standard surfaces aluminium anodised**  
Option: seawater-resistant hart-coated or seawater-resistant protective lacquer

## User-defined designs

### SL3001-... / GS 55

- measuring length max. 1.250 mm
- compact Rope Length Transducer with integrated encoder system
- signal outputs: incremental, potentiometric, analogue, digital
- applications: automation, wood industry

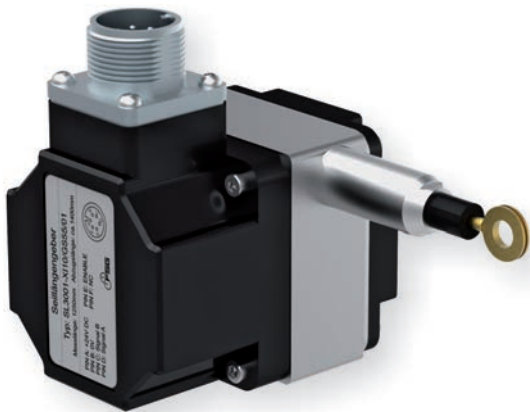

### SL04-... / GS 160

- measuring length max. 4.000 mm
- robust Rope Length Transmitter with integrated encoder system
- measuring wire Ø 3 mm
- application: drill trucks



### SL010-... / GS 125

- measuring length max. 10.000 mm
- space saving Rope Length Transmitter with integrated encoder system
- outer outline matched to installation condition
- application: road/rail tower vehicle



### SL20-... / GS 190

- measuring length max. 20.000 mm
- open Rope Length Transmitter with attached encoder system
- measuring wire Ø 2 mm, drum with screwed-in flute
- application: casting bay





# Applications



## Construction and special-purpose vehicles

- for measurement of
  - length of extension arm
  - position of support beam
  - position of trolley
- positioning of
  - moveable tools
  - drilling rigs



## Drilling platforms and other offshore applications

- positioning of mounting robots for drilling facility
- jib positioning of loading cranes
- determination of gear position of marine propeller



## Industrial facilities

- fill level for
  - grain stores
  - biogas generation
- position recording of weir and dam gates
- length recording at machine tools

### **Mobile elevating working platforms as well as conveying systems**

- height recording of working platforms
- detection of extension arm length
- positioning of theatre stages
- height determination of conveying systems at assembly lines



### **Medical engineering**

- lifting mechanism and moving apparatus for examination tables
- positioning of medical equipment
- length recording for rehabilitation and sports equipment



### **Elevators and lifting systems**

- height recording for elevators
- positioning of storage robots at high-bay rackings
- mobile lifting systems for container traffic







Headquarter in Berlin

## Berlin

---

### Fernsteuergeräte

#### Kurt Oelsch GmbH

Jahnstraße 68 + 70

D-12347 Berlin

Phone +49 (0 30) 62 91 - 1

Fax +49 (0 30) 62 91 - 277



Factory in Kablow

## Kablow

---

### FSG Fernsteuergeräte

#### Meß- und Regeltechnik GmbH

OT Kablow

Mühlenweg 2-3

D-15712 Königs Wusterhausen

Phone +49 (0 33 75) 269 - 0

Fax +49 (0 33 75) 269 - 277



Factory in Heppenheim

## Heppenheim

---

### Fernsteuergeräte

#### Kurt Oelsch GmbH & Co.KG

Weierhausstraße 10

D-64646 Heppenheim

Phone +49 (0 62 52) 99 50 - 0

Fax +49 (0 62 52) 72 05 - 3



info@fernsteuergeraete.de  
www.fernsteuergeraete.de