

RA554VF ST558VF

Acier zingué	Inox	Super Extension	 Français	2
Zinc plated steel	Stainless steel	Over Extension	 English	3
Stahl silbern verzinkt	Edelstahl	Überauszüge	 Deutsch	4
Pozinkovaná ocel	Nerezová ocel	Extra výsuv	 Český	5
Acero zincado	Acero inoxidable	Super Extension	 Español	6
Acciaio zincato	Acciaio inox	Super Estensione	 Italiano	7
Verzinkt staal	Roestvrij staal	Over uittrekbaar	 Nederlands	8
Оцинковка	Нержавеющая сталь	Сверхвыдвижение	 Русский	9
Stal ocynkowana	Stal nierdzewna	Wysuw powyżej pełnego	 Polski	10

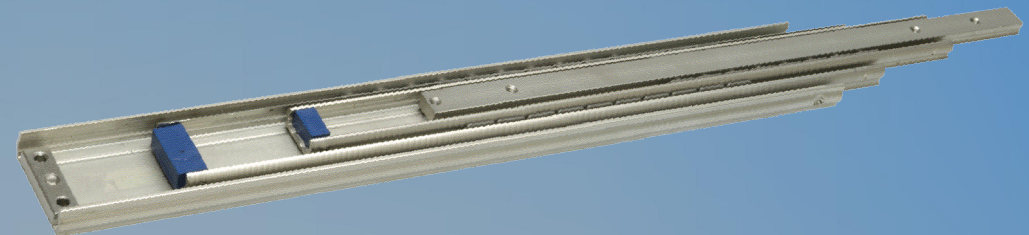

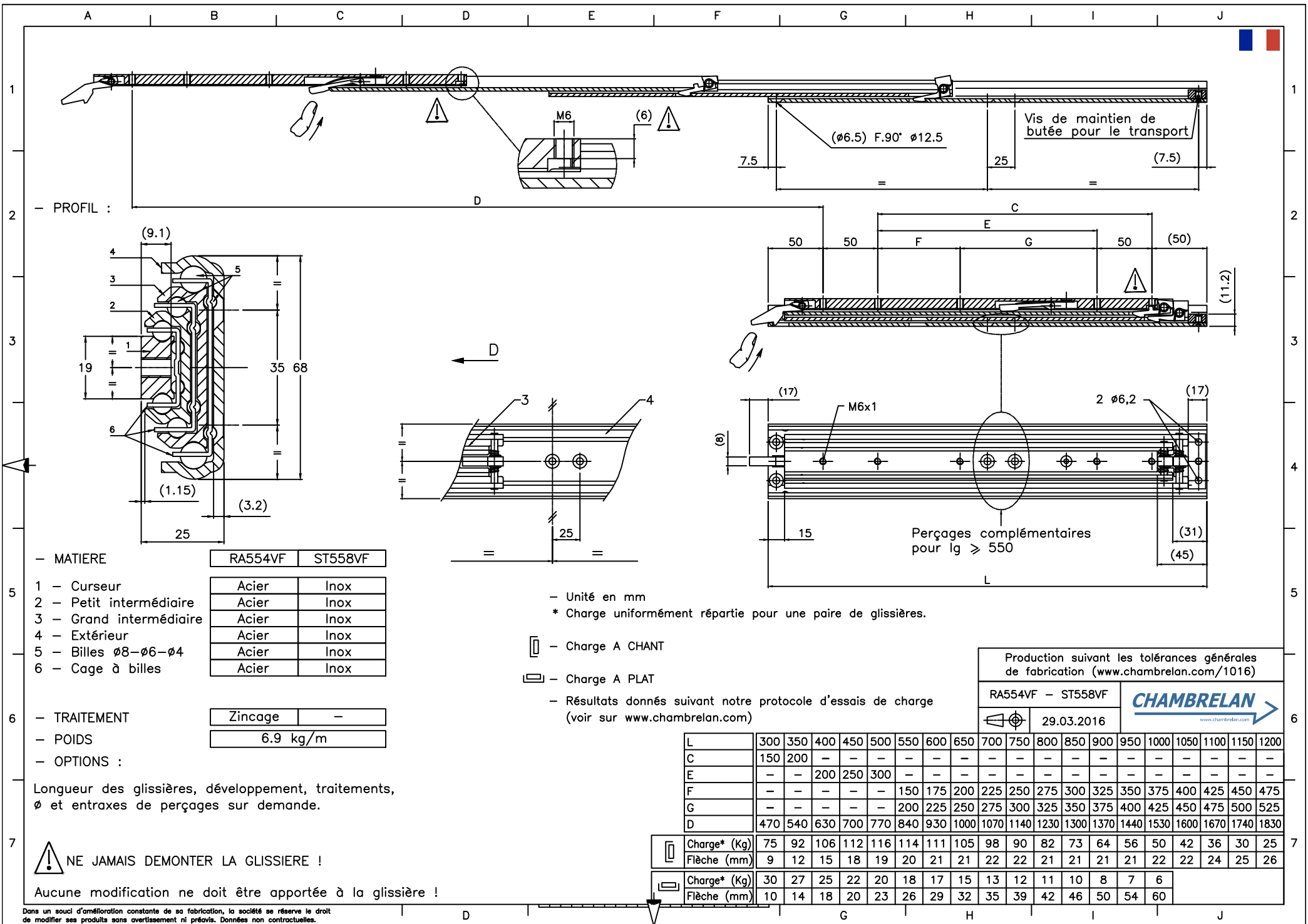

PROFIL :

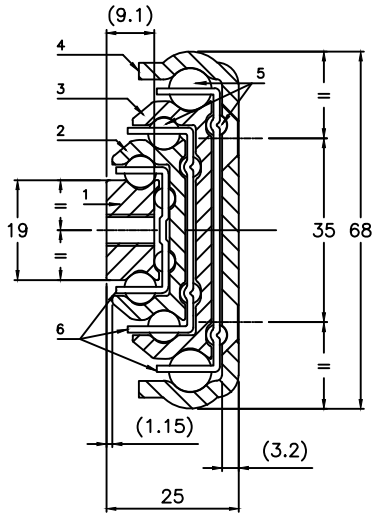

MATIERE

	RA554VF	ST558VF
1 - Curseur	Acier	Inox
2 - Petit intermédiaire	Acier	Inox
3 - Grand intermédiaire	Acier	Inox
4 - Extérieur	Acier	Inox
5 - Billes Ø8-Ø6-Ø4	Acier	Inox
6 - Cage à billes	Acier	Inox

TRAITEMENT

Zincage	-
POIDS	6.9 kg/m

OPTIONS :

Longueur des glissières, développement, traitements, Ø et entraxes de perçages sur demande.

NE JAMAIS DEMONTER LA GLISSIERE !

Aucune modification ne doit être apportée à la glissière !

- Unité en mm
* Charge uniformément répartie pour une paire de glissières.

☐ - Charge A CHANT
▭ - Charge A PLAT

- Résultats donnés suivant notre protocole d'essais de charge (voir sur www.chambrelan.com)

Production suivant les tolérances générales de fabrication (www.chambrelan.com/1016)

RA554VF - ST558VF		CHAMBRELAN www.chambrelan.com
29.03.2016		

L	300	350	400	450	500	550	600	650	700	750	800	850	900	950	1000	1050	1100	1150	1200	
C	150	200	-	-	-	-	-	-	-	-	-	-	-	-	-	-	-	-	-	-
E	-	-	200	250	300	-	-	-	-	-	-	-	-	-	-	-	-	-	-	-
F	-	-	-	-	-	150	175	200	225	250	275	300	325	350	375	400	425	450	475	500
G	-	-	-	-	-	200	225	250	275	300	325	350	375	400	425	450	475	500	525	550
D	470	540	630	700	770	840	930	1000	1070	1140	1230	1300	1370	1440	1530	1600	1670	1740	1830	1920

☐	Charge* (Kg)	75	92	106	112	116	114	111	105	98	90	82	73	64	56	50	42	36	30	25
☐	Flèche (mm)	9	12	15	18	19	20	21	22	22	22	21	21	21	21	22	22	24	25	26
▭	Charge* (Kg)	30	27	25	22	20	18	17	15	13	12	11	10	8	7	6	-	-	-	-
▭	Flèche (mm)	10	14	18	20	23	26	29	32	35	39	42	46	50	54	60	-	-	-	-

Dans un souci d'amélioration constante de sa fabrication, la société se réserve le droit de modifier ses produits sans avertissement ni préavis. Données non contractuelles.

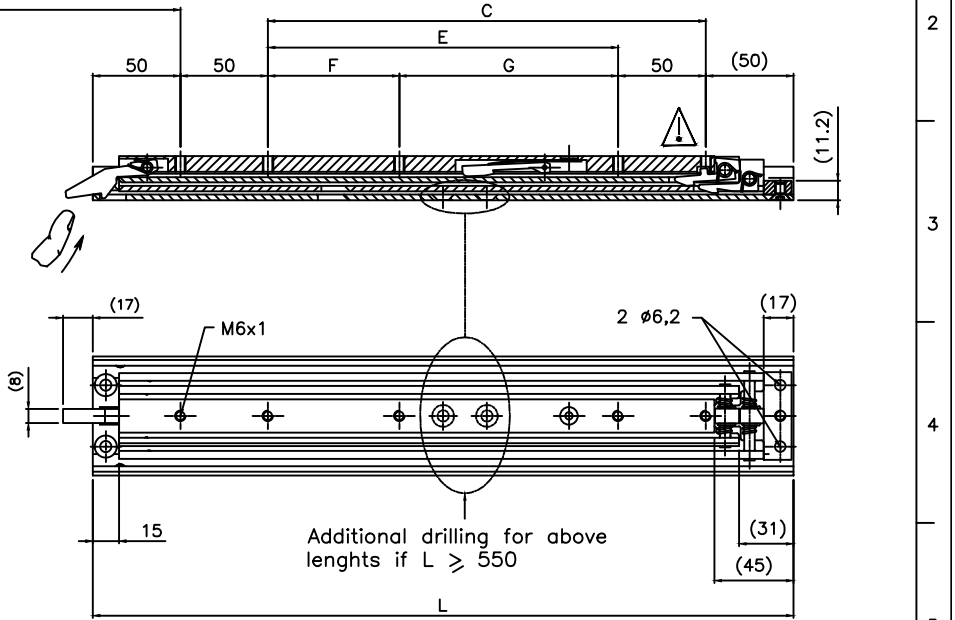
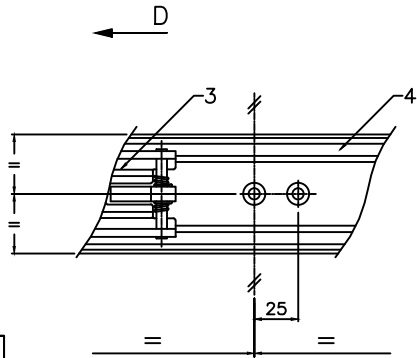
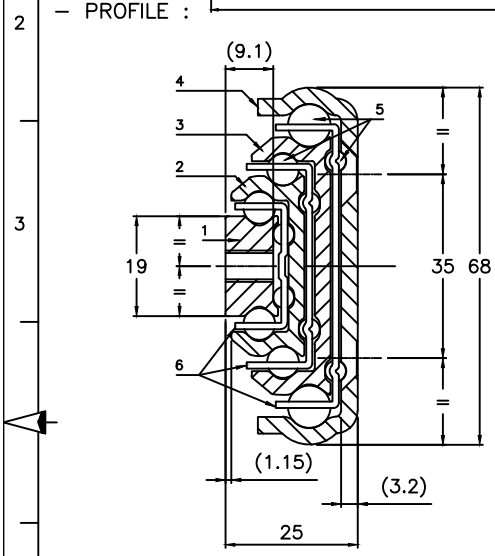
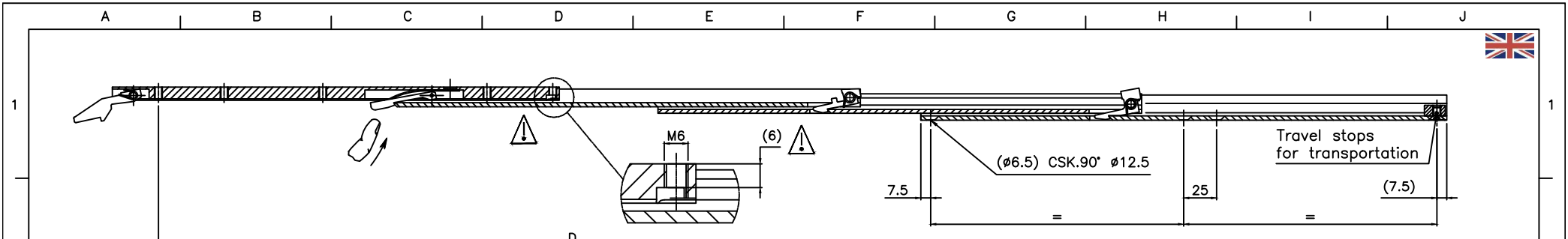

MATERIAL

	RA554VF	ST558VF
1 - Inner beam	Steel	Stainless steel
2 - Intermediate beam	Steel	Stainless steel
3 - Intermediate beam	Steel	Stainless steel
4 - Outer beam	Steel	Stainless steel
5 - Bearing $\phi 8-\phi 6-\phi 4$	Steel	Stainless steel
6 - Ball cages	Steel	Stainless steel

SURFACE FINISH

Zinc plating	-
--------------	---

WEIGHT

6.9 kg/m

OPTIONS :

Different slide lengths, extension, surface finish, ϕ and holes centres to customer's requirement.

! DO NOT DISMOUNT THE SLIDE !

Do not modify the slides !

- Dimensions in mm
* Loads indicated for a pair of slides

- Load in a major axis
 - Load in a minor axis

- Results given according to our load testing protocol
(www.chambreilan.com)

Production according our general manufacturing tolerances (www.chambreilan.com/1016)

RA554VF - ST558VF	CHAMBREILAN
29.03.2016	www.chambreilan.com

L	300	350	400	450	500	550	600	650	700	750	800	850	900	950	1000	1050	1100	1150	1200	
C	150	200	-	-	-	-	-	-	-	-	-	-	-	-	-	-	-	-	-	-
E	-	-	200	250	300	-	-	-	-	-	-	-	-	-	-	-	-	-	-	-
F	-	-	-	-	-	150	175	200	225	250	275	300	325	350	375	400	425	450	475	500
G	-	-	-	-	-	200	225	250	275	300	325	350	375	400	425	450	475	500	525	550
D	470	540	630	700	770	840	930	1000	1070	1140	1230	1300	1370	1440	1530	1600	1670	1740	1830	1920

	Load* (Kg)	75	92	106	112	116	114	111	105	98	90	82	73	64	56	50	42	36	30	25
	Deflexion (mm)	9	12	15	18	19	20	21	21	22	22	21	21	21	21	22	22	24	25	26
	Load* (Kg)	30	27	25	22	20	18	17	15	13	12	11	10	8	7	6	-	-	-	-
	Deflexion (mm)	10	14	18	20	23	26	29	32	35	39	42	46	50	54	60	-	-	-	-

In a constant effort of improvement, the company reserves the right to modify its products without notice. No contractual information.

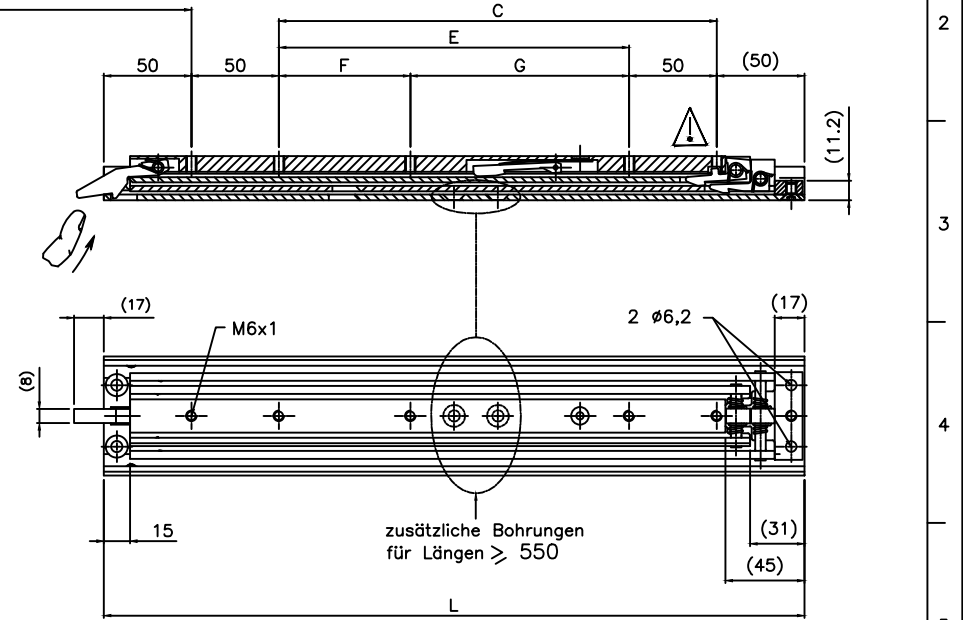
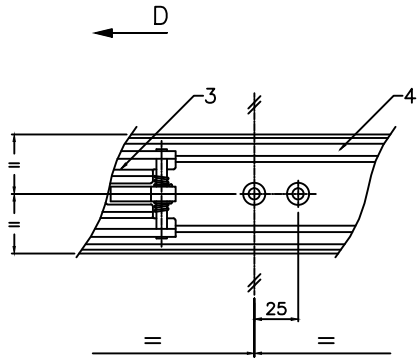
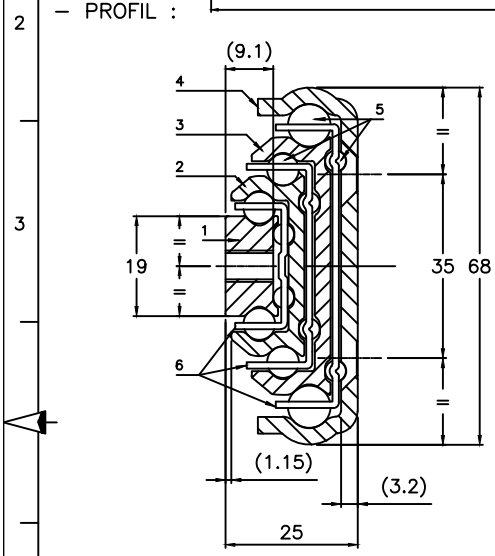
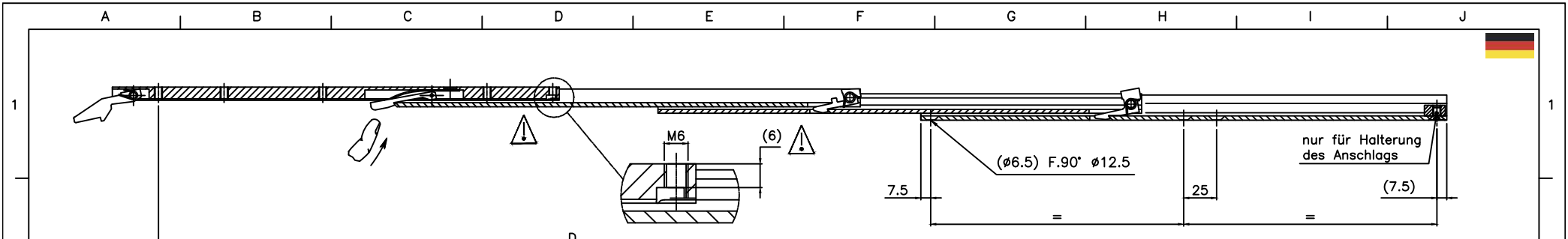

Material	RA554VF	ST558VF
1 - Kleine innenschiene	Stahl	Edelstahl
2 - Mittelschiene	Stahl	Edelstahl
3 - große Mittelschiene	Stahl	Edelstahl
4 - Außenschiene	Stahl	Edelstahl
5 - Kugeln $\phi 8-\phi 6-\phi 4$	Stahl	Edelstahl
6 - Kugelleisten	Stahl	Edelstahl

Oberflächenbehandlung	silbern verzinkt	-
Gewicht	6.9 kg/m	

mögliche Sonderanfertigungen :
Sonderlängen, Oberflächenbehandlungen,
 ϕ Bohrungen und Lochabstände.

- Maße in mm
* Belastungsangaben gelten pro Paar

- Tragfähigkeit radial
 - Tragfähigkeit axial

- Resultate nach unserem üblichen Testverfahren
(siehe unter www.chambrelan.com)

Herstellung nach unseren allgemeinen
Herstellungstoleranzen (siehe www.chambrelan.com/1016)

RA554VF - ST558VF	
29.03.2016	

L	300	350	400	450	500	550	600	650	700	750	800	850	900	950	1000	1050	1100	1150	1200
C	150	200	-	-	-	-	-	-	-	-	-	-	-	-	-	-	-	-	-
E	-	-	200	250	300	-	-	-	-	-	-	-	-	-	-	-	-	-	-
F	-	-	-	-	-	150	175	200	225	250	275	300	325	350	375	400	425	450	475
G	-	-	-	-	-	200	225	250	275	300	325	350	375	400	425	450	475	500	525
D	470	540	630	700	770	840	930	1000	1070	1140	1230	1300	1370	1440	1530	1600	1670	1740	1830

	Belastung*(Kg)	75	92	106	112	116	114	111	105	98	90	82	73	64	56	50	42	36	30	25
	Durchbiegung	9	12	15	18	19	20	21	21	22	22	21	21	21	21	22	22	24	25	26
	Belastung*(Kg)	30	27	25	22	20	18	17	15	13	12	11	10	8	7	6	-	-	-	-
	Durchbiegung	10	14	18	20	23	26	29	32	35	39	42	46	50	54	60	-	-	-	-

DIE SCHIENEN NICHT DEMONTIEREN !

DIE TELESKOPSCHIENE DARF NICHT VERÄNDERT WERDEN!

Um die ständige Verbesserung unserer Schienen zu gewährleisten, behalten wir uns ohne Voranmeldung technische Änderungen vor. Keine vertragmäßigen Informationen.