



General-Purpose AC Servo

MITSUBISHI SERVO AMPLIFIERS & MOTORS
MELSERVO-JE

General-Purpose Interface AC Servo

MODEL

MR-JE- A

SERVO AMPLIFIER

INSTRUCTION MANUAL

(Modbus RTU Protocol)

● Safety Instructions ●

Please read the instructions carefully before using the equipment.

To use the equipment correctly, do not attempt to install, operate, maintain, or inspect the equipment until you have read through this Instruction Manual, Installation guide, and appended documents carefully. Do not use the equipment until you have a full knowledge of the equipment, safety information and instructions. In this Instruction Manual, the safety instruction levels are classified into "WARNING" and "CAUTION".



Indicates that incorrect handling may cause hazardous conditions, resulting in death or severe injury.



Indicates that incorrect handling may cause hazardous conditions, resulting in medium or slight injury to personnel or may cause physical damage.

Note that the  CAUTION level may lead to a serious consequence according to conditions.

Please follow the instructions of both levels because they are important to personnel safety.

What must not be done and what must be done are indicated by the following diagrammatic symbols.



Indicates what must not be done. For example, "No Fire" is indicated by .



Indicates what must be done. For example, grounding is indicated by .

In this Instruction Manual, instructions at a lower level than the above, instructions for other functions, and so on are classified into "POINT".

After reading this Instruction Manual, keep it accessible to the operator.

1. To prevent electric shock, note the following

WARNING

- Before wiring and inspections, turn off the power and wait for 15 minutes or more until the charge lamp turns off. Otherwise, an electric shock may occur. In addition, when confirming whether the charge lamp is off or not, always confirm it from the front of the servo amplifier.
- Ground the servo amplifier and servo motor securely.
- Any person who is involved in wiring and inspection should be fully competent to do the work.
- Do not attempt to wire the servo amplifier and servo motor until they have been installed. Otherwise, it may cause an electric shock.
- Do not operate switches with wet hands. Otherwise, it may cause an electric shock.
- The cables should not be damaged, stressed, loaded, or pinched. Otherwise, it may cause an electric shock.
- To prevent an electric shock, always connect the protective earth (PE) terminal (marked \oplus) of the servo amplifier to the protective earth (PE) of the cabinet.
- To avoid an electric shock, insulate the connections of the power supply terminals.

2. To prevent fire, note the following

CAUTION

- Install the servo amplifier, servo motor, and regenerative resistor on incombustible material. Installing them directly or close to combustibles will lead to smoke or a fire.
- Always connect a magnetic contactor between the power supply and the power supply (L1/L2/L3) of the servo amplifier, in order to configure a circuit that shuts down the power supply on the side of the servo amplifier's power supply. If a magnetic contactor is not connected, continuous flow of a large current may cause smoke or a fire when the servo amplifier malfunctions.
- Always connect a molded-case circuit breaker, or a fuse to each servo amplifier between the power supply and the power supply (L1/L2/L3) of the servo amplifier, in order to configure a circuit that shuts down the power supply on the side of the servo amplifier's power supply. If a molded-case circuit breaker or fuse is not connected, continuous flow of a large current may cause smoke or a fire when the servo amplifier malfunctions.
- When using the regenerative resistor, switch power off with the alarm signal. Otherwise, a regenerative transistor malfunction or the like may overheat the regenerative resistor, causing smoke or a fire.
- When you use a regenerative option with an MR-JE-40A to MR-JE-100A, remove the built-in regenerative resistor and wiring from the servo amplifier.
- Provide adequate protection to prevent screws and other conductive matter, oil and other combustible matter from entering the servo amplifier and servo motor.

3. To prevent injury, note the following

CAUTION

- Only the power/signal specified in the Instruction Manual must be supplied/applied to each terminal. Otherwise, an electric shock, fire, injury, etc. may occur.
- Connect cables to the correct terminals. Otherwise, a burst, damage, etc. may occur.
- Ensure that polarity (+/-) is correct. Otherwise, a burst, damage, etc. may occur.
- The servo amplifier heat sink, regenerative resistor, servo motor, etc., may be hot while the power is on and for some time after power-off. Take safety measures such as providing covers to avoid accidentally touching them by hands and parts such as cables.

4. Additional instructions

The following instructions should also be fully noted. Incorrect handling may cause a malfunction, injury, electric shock, fire, etc.

(1) Transportation and installation

CAUTION

- Transport the products correctly according to their mass.
- Stacking in excess of the specified number of product packages is not allowed.
- Do not hold the lead of the built-in regenerative resistor, cables, or connectors when carrying the servo amplifier. Otherwise, it may drop.
- Install the servo amplifier and the servo motor in a load-bearing place in accordance with the Instruction Manual.
- Do not get on or put heavy load on the equipment. Otherwise, it may cause injury.
- The equipment must be installed in the specified direction.
- Leave specified clearances between the servo amplifier and the cabinet walls or other equipment.
- Do not install or operate the servo amplifier and servo motor which have been damaged or have any parts missing.
- Do not block the intake and exhaust areas of the servo amplifier. Otherwise, it may cause a malfunction.
- Do not drop or apply heavy impact on the servo amplifiers and the servo motors. Otherwise, injury, malfunction, etc. may occur.
- Do not strike the connector. Otherwise, a connection failure, malfunction, etc. may occur.
- When you keep or use the equipment, please fulfill the following environment.

Item		Environment
Ambient temperature	Operation	0 °C to 55 °C (non-freezing)
	Storage	-20 °C to 65 °C (non-freezing)
Ambient humidity	Operation	5 %RH to 90 %RH (non-condensing)
	Storage	
Ambience		Indoors (no direct sunlight), free from corrosive gas, flammable gas, oil mist, dust, and dirt
Altitude		2000 m or less above sea level (Contact your local sales office for the altitude for options.)
Vibration resistance		5.9 m/s ² , at 10 Hz to 55 Hz (directions of X, Y and Z axes)

- When the product has been stored for an extended period of time, contact your local sales office.
- When handling the servo amplifier, be careful about the edged parts such as corners of the servo amplifier.
- The servo amplifier must be installed in a metal cabinet.
- When fumigants that contain halogen materials such as fluorine, chlorine, bromine, and iodine are used for disinfecting and protecting wooden packaging from insects, they cause malfunction when entering our products. Please take necessary precautions to ensure that remaining materials from fumigant do not enter our products, or treat packaging with methods other than fumigation (heat method). Additionally, disinfect and protect wood from insects before packing products.
- To prevent a fire or injury from occurring in case of an earthquake or other natural disasters, securely install, mount, and wire the servo motor in accordance with the Instruction Manual.

(2) Wiring

⚠ CAUTION

- Before removing the CNP1 connector of MR-JE-40A to MR-JE-100A, disconnect the lead wires of the regenerative resistor from the CNP1 connector.
- Wire the equipment correctly and securely. Otherwise, the servo motor may operate unexpectedly.
- Make sure to connect the cables and connectors by using the fixing screws and the locking mechanism. Otherwise, the cables and connectors may be disconnected during operation.
- Do not install a power capacitor, surge killer, or radio noise filter (optional FR-BIF) on the servo amplifier output side.
- To avoid a malfunction, connect the wires to the correct phase terminals (U/V/W) of the servo amplifier and servo motor.
- Connect the servo amplifier power output (U/V/W) to the servo motor power input (U/V/W) directly. Do not let a magnetic contactor, etc. intervene. Otherwise, it may cause a malfunction.

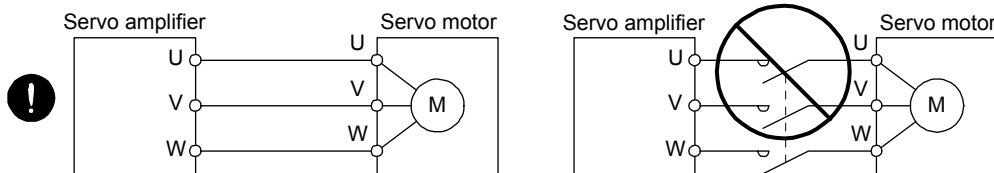

- The connection diagrams in this instruction manual are shown for sink interfaces, unless stated otherwise.
- The surge absorbing diode installed to the DC relay for control output should be fitted in the specified direction. Otherwise, the emergency stop and other protective circuits may not operate.

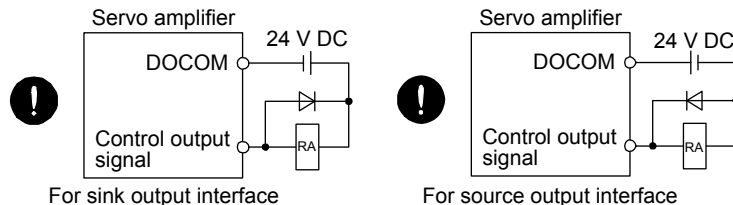

- When the cable is not tightened enough to the terminal block, the cable or terminal block may generate heat because of the poor contact. Be sure to tighten the cable with specified torque.
- Connecting a servo motor of the wrong axis to U, V, W, or CN2 of the servo amplifier may cause a malfunction.
- Configure a circuit to turn off EM2 or EM1 when the power supply is turned off to prevent an unexpected restart of the servo amplifier.
- To prevent malfunction, avoid bundling power lines (input/output) and signal cables together or running them in parallel to each other. Separate the power lines from the signal cables.

(3) Test run and adjustment

⚠ CAUTION

- When executing a test run, follow the notice and procedures in this instruction manual. Otherwise, it may cause a malfunction, damage to the machine, or injury.
- Before operation, check the parameter settings. Improper settings may cause some machines to operate unexpectedly.

CAUTION

- Never adjust or change the parameter values extremely as it will make operation unstable.
- Do not get close to moving parts during the servo-on status.

(4) Usage

CAUTION

- When it is assumed that a hazardous condition may occur due to a power failure or product malfunction, use a servo motor with an external brake to prevent the condition.
- For equipment in which the moving part of the machine may collide against the load side, install a limit switch or stopper to the end of the moving part. The machine may be damaged due to a collision.
- Do not disassemble, repair, or modify the product. Otherwise, an electric shock, fire, injury, etc. may occur. Disassembled, repaired, and/or modified products are not covered under warranty.
- Before resetting an alarm, make sure that the run signal of the servo amplifier is off in order to prevent a sudden restart. Otherwise, it may cause an accident.
- Use a noise filter, etc. to minimize the influence of electromagnetic interference. Electromagnetic interference may be given to the electronic equipment used near the servo amplifier.
- Burning or breaking a servo amplifier may cause a toxic gas. Do not burn or break it.
- Use the servo amplifier with the specified servo motor.
- Correctly wire options and peripheral equipment, etc. in the correct combination. Otherwise, an electric shock, fire, injury, etc. may occur.
- The electromagnetic brake on the servo motor is designed to hold the motor shaft and should not be used for ordinary braking.
- For such reasons as incorrect wiring, service life, and mechanical structure (e.g. where a ball screw and the servo motor are coupled via a timing belt), the electromagnetic brake may not hold the motor shaft. To ensure safety, install a stopper on the machine side.
- If the dynamic brake is activated at power-off, alarm occurrence, etc., do not rotate the servo motor by an external force. Otherwise, it may cause a fire.

(5) Corrective actions

CAUTION

- Ensure safety by confirming the power off, etc. before performing corrective actions. Otherwise, it may cause an accident.
- If it is assumed that a power failure, machine stoppage, or product malfunction may result in a hazardous situation, use a servo motor with an electromagnetic brake or provide an external brake system for holding purpose to prevent such hazard.
- When any alarm has occurred, eliminate its cause, ensure safety, and deactivate the alarm before restarting operation.
- If the molded-case circuit breaker or fuse is activated, be sure to remove the cause and secure safety before switching the power on. If necessary, replace the servo amplifier and recheck the wiring. Otherwise, it may cause smoke, fire, or an electric shock.
- Provide an adequate protection to prevent unexpected restart after an instantaneous power failure.

⚠ CAUTION

- Configure an electromagnetic brake circuit which is interlocked with an external emergency stop switch.

Contacts must be opened when ALM (Malfunction) or MBR (Electromagnetic brake interlock) turns off.

Contacts must be opened with the emergency stop switch.

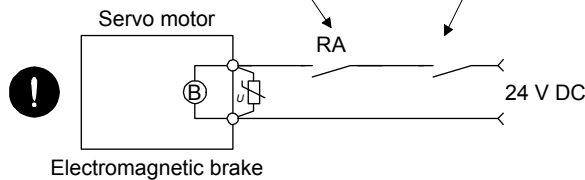

- To prevent an electric shock, injury, or fire from occurring after an earthquake or other natural disasters, ensure safety by checking conditions, such as the installation, mounting, wiring, and equipment before switching the power on.

(6) Maintenance, inspection and parts replacement

⚠ CAUTION

- Make sure that the emergency stop circuit operates properly such that an operation can be stopped immediately and a power is shut off by the emergency stop switch.
- It is recommended that the servo amplifier be replaced every 10 years when it is used in general environment.
- When using a servo amplifier whose power has not been turned on for a long time, contact your local sales office.

(7) General instruction

- To illustrate details, the equipment in the diagrams of this Instruction Manual may have been drawn without covers and safety guards. When the equipment is operated, the covers and safety guards must be installed as specified. Operation must be performed in accordance with this Instruction Manual.

● DISPOSAL OF WASTE ●

Please dispose a servo amplifier and other options according to your local laws and regulations.

EEPROM life

The number of write times to the EEPROM, which stores parameter settings, etc., is limited to 100,000. If the total number of the following operations exceeds 100,000, the servo amplifier may malfunction when the EEPROM reaches the end of its useful life.

- Write to the EEPROM due to parameter setting changes
- Write to the EEPROM due to device changes
- Write to the EEPROM due to point table setting changes
- Write to the EEPROM due to program setting changes

Compliance with global standards

For the compliance with global standards, refer to app. 2 of "MELSERVO-JE-_A Servo Amplifier Instruction Manual".

«About the manual»

You must have this Instruction Manual and the following manuals to use this servo. Ensure to prepare them to use the servo safely.

Relevant manuals

Manual name	Manual number
MELSERVO MR-JE-_A Servo Amplifier Instruction Manual	SH(NA)030128ENG
MELSERVO MR-JE-_A Servo Amplifier Instruction Manual (Positioning Mode)	SH(NA)030150ENG
MELSERVO-JE Servo Amplifier Instruction Manual (Troubleshooting)	SH(NA)030166ENG
MELSERVO HG-KN_/HG-SN_ Servo Motor Instruction Manual	SH(NA)030135ENG
MELSERVO EMC Installation Guidelines	IB(NA)67310ENG

«U.S. customary units»

U.S. customary units are not shown in this manual. Convert the values if necessary according to the following table.

Quantity	SI (metric) unit	U.S. customary unit
Mass	1 [kg]	2.2046 [lb]
Length	1 [mm]	0.03937 [inch]
Torque	1 [N·m]	141.6 [oz·inch]
Moment of inertia	1 [(× 10 ⁻⁴ kg·m ²)]	5.4675 [oz·inch ²]
Load (thrust load/axial load)	1 [N]	0.2248 [lbf]
Temperature	N [°C] × 9/5 + 32	N [°F]

CONTENTS

1. FUNCTIONS AND CONFIGURATION	1- 1 to 1- 4
1.1 Summary.....	1- 1
1.2 Function List.....	1- 2
1.3 Communication Specifications.....	1- 2
1.4 System Configuration	1- 3
1.4.1 Diagrammatic sketch.....	1- 3
1.4.2 Cable connection diagram	1- 4
2. PARAMETER	2- 1 to 2- 6
2.1 Detailed list of parameters	2- 2
2.2 Restrictions on using Modbus RTU communication.....	2- 5
3. MODBUS PROTOCOL	3- 1 to 3-10
3.1 Modbus RTU Message Format.....	3- 1
3.2 Broadcast Communication.....	3- 1
3.3 Modbus RTU Communication Message Frame	3- 2
3.4 Function Codes.....	3- 3
3.4.1 List of function codes	3- 3
3.4.2 Read Holding Registers (Reading data in holding registers: 03h).....	3- 4
3.4.3 Diagnostics (Function diagnostics: 08h)	3- 6
3.4.4 Preset Multiple Registers (Writing data in multiple holding registers: 10h)	3- 8
3.4.5 Processing at occurrence of an error.....	3-10
4. MODBUS REGISTERS	4- 1 to 4-22
4.1 List of Available Registers	4- 1
4.2 Monitor (Address: 2B01h to 2B7Fh)	4- 2
4.2.1 List of registers	4- 2
4.2.2 Directions for use	4- 3
4.3 Parameter Setting (Address: 2001h to 27FFh).....	4- 4
4.3.1 List of registers	4- 4
4.3.2 Directions for use	4- 4
4.4 Point Table Setting (Address: 2801h to 281Fh)	4- 5
4.4.1 List of registers	4- 5
4.4.2 Directions for use	4- 5
4.5 Writing Command to EEP-ROM (Address: 1010h)	4- 5
4.5.1 List of registers	4- 5
4.5.2 Directions for use	4- 6
4.6 Alarm Information (Address: 1001h).....	4- 7
4.6.1 List of registers	4- 7
4.6.2 Directions for use	4- 7
4.7 Alarm Number (Address: 2A41h)	4- 7
4.7.1 List of registers	4- 7
4.7.2 Directions for use	4- 7
4.8 Alarm Occurrence Monitor (Address: 2B81h to 2BFFh).....	4- 8
4.8.1 List of registers	4- 8

4.8.2	Directions for use	4- 9
4.9	Alarm History (Address: 2A00h to 2A0Fh)	4-10
4.9.1	List of registers	4-10
4.9.2	Directions for use	4-10
4.10	Alarm History Clear (Address: 2A40h)	4-10
4.10.1	List of registers	4-10
4.10.2	Directions for use	4-10
4.11	Parameter Error Count (Address: 2A44h)	4-11
4.11.1	List of registers	4-11
4.11.2	Directions for use	4-11
4.12	Parameter Error List (Address: 2A45h)	4-11
4.12.1	List of registers	4-11
4.12.2	Directions for use	4-11
4.13	Point Table Error (Address: 2A43h)	4-12
4.13.1	List of registers	4-12
4.13.2	Directions for use	4-12
4.14	External Input Pin Status (Address: 2C10h).....	4-13
4.14.1	List of registers	4-13
4.14.2	Directions for use	4-13
4.15	External Output Pin Status (Address: 2C11h).....	4-14
4.15.1	List of registers	4-14
4.15.2	Directions for use	4-14
4.16	Input Device Status (Address: 2C12h)	4-14
4.16.1	List of registers	4-14
4.16.2	Directions for use	4-15
4.17	Output Device Status (Address: 2C13h)	4-16
4.17.1	List of registers	4-16
4.17.2	Directions for use	4-17
4.18	Servo Amplifier Model (Address: 1008h).....	4-18
4.18.1	List of registers	4-18
4.18.2	Directions for use	4-18
4.19	Servo Amplifier Software Version (Address: 100Ah).....	4-18
4.19.1	List of registers	4-18
4.19.2	Directions for use	4-18
4.20	Broadcast Setting (Address: 2D98h).....	4-19
4.20.1	List of registers	4-19
4.20.2	Directions for use	4-19
4.21	Servo Motor Rated Speed (Address: 2D28h).....	4-19
4.21.1	List of registers	4-19
4.21.2	Directions for use	4-19
4.22	Servo Motor Maximum Speed (Address: 2D29h).....	4-19
4.22.1	List of registers	4-19
4.22.2	Directions for use	4-19
4.23	SDO Abort Code (Address: 2A60h).....	4-20
4.23.1	List of registers	4-20
4.23.2	Directions for use	4-20
4.24	Access Log 1 (Address: 2A64h)	4-20
4.24.1	List of registers	4-20
4.24.2	Directions for use	4-20
4.25	Access Log 2 (Address: 2A65h)	4-21

4.25.1	List of registers	4-21
4.25.2	Directions for use	4-21
4.26	Communication Error Count (Address: 2A68h).....	4-21
4.26.1	List of registers	4-21
4.26.2	Directions for use	4-21
4.27	Supported Profile Information (Address: 1000h).....	4-22
4.27.1	List of registers	4-22
4.27.2	Directions for use	4-22
4.28	Device Information (Address: 1018h).....	4-22
4.28.1	List of registers	4-22
4.28.2	Directions for use	4-22

5. DRIVING MOTOR	5- 1 to 5-46
-------------------------	---------------------

5.1	Device Control	5- 2
5.1.1	Function description	5- 2
5.1.2	Related registers	5- 3
5.1.3	Details of registers	5- 3
5.1.4	Directions for use	5- 4
5.2	Control Mode	5- 5
5.2.1	Function description	5- 5
5.2.2	Related registers	5- 5
5.2.3	Details of registers	5- 5
5.2.4	Directions for use	5- 7
5.3	Home Position Return Mode.....	5- 7
5.3.1	Function description	5- 7
5.3.2	Related registers	5- 8
5.3.3	Details of registers	5- 8
5.3.4	Directions for use	5-12
5.4	JOG Operation Mode.....	5-13
5.4.1	Function description	5-13
5.4.2	Related registers	5-13
5.4.3	Details of registers	5-14
5.4.4	Directions for use	5-17
5.5	Point Table Operation Mode.....	5-18
5.5.1	Function description	5-18
5.5.2	Related registers	5-18
5.5.3	Details of registers	5-19
5.5.4	Directions for use	5-22
5.6	Program Operation Mode	5-24
5.6.1	Function description	5-24
5.6.2	Related registers	5-24
5.6.3	Details of registers	5-25
5.6.4	Directions for use	5-27
5.7	Touch Probe (Address: 60B8h to 60BBh)	5-28
5.7.1	Function description	5-28
5.7.2	List of registers	5-28
5.7.3	Details of registers	5-29
5.7.4	Directions for use	5-31
5.8	Function common to the modes	5-33
5.8.1	List of registers	5-33

5.8.2	Control input (2D01h to 2D09h)	5-33
5.8.3	Control output (2D11h to 2D19h).....	5-38
5.8.4	Simultaneous start bit setting (2D9Ah)	5-43
5.8.5	Controller force stop (2D9Bh)	5-43
5.8.6	Override (2DB0h).....	5-44
5.8.7	Forward torque limit value (60E0h).....	5-44
5.8.8	Reverse torque limit value (60E1h).....	5-44
5.8.9	Current position (6064h)	5-44
5.8.10	Current speed (606Ch)	5-44
5.8.11	Current torque (6077h)	5-45
5.8.12	Cam number setting (2D80h).....	5-45
5.8.13	Current cam number (2D82h).....	5-45
5.8.14	Cam axis one-cycle length setting (2D84h)	5-45
5.8.15	Cam stroke length setting (2D85h)	5-46
5.8.16	Request store CAM (2D88h).....	5-46
5.8.17	CAM area (2D89h).....	5-46
5.8.18	CAM data in CAM area (2D8Bh).....	5-46

6. LIST OF MODBUS REGISTERS	6- 1 to 6- 4
-----------------------------	--------------

7. APPLICATION OF FUNCTIONS	7- 1 to 7- 4
-----------------------------	--------------

7.1	Connection with GOT2000 series.....	7- 1
7.1.1	Access to Modbus registers	7- 1

1. FUNCTIONS AND CONFIGURATION

1. FUNCTIONS AND CONFIGURATION

This instruction manual describes the communication with the MR-JE-_A servo amplifiers using the Modbus RTU communication protocol. Refer to "MELSERVO-JE-_A Servo Amplifier Instruction Manual" and "MELSERVO-JE-_A Servo Amplifier Instruction Manual (Positioning Mode)" for the items not given in this manual.

1.1 Summary

POINT
●The Modbus RTU communication function is supported by servo amplifiers manufactured in May 2015 or later.
●Note that using the Modbus RTU communication function prevents the RS-422/RS-485 communication function (Mitsubishi Electric general-purpose AC servo protocol) from being used, and vice versa. They cannot be used together.

The Modbus protocol developed for programmable controllers is provided by Modicon Inc.

The Modbus protocol uses dedicated message frames for the serial communication between a master and slaves. Using the functions in the message frames enables to read or write data from/to parameters, write input commands, and check operation status of servo amplifiers.

For MR-JE-_A servo amplifier, Modbus registers are assigned like the address assignment of CiA 402 drive profile.

A Modbus-compatible controller, the master, can communicate with the MR-JE-_A servo amplifiers that are slaves by accessing assigned holding registers.

The ASCII (American Standard Code for Information Interchange) mode and the RTU (Remote Terminal Unit) mode are provided as the serial transmission modes of the Modbus protocol. The MR-JE-_A servo amplifiers support only the RTU mode.

1. FUNCTIONS AND CONFIGURATION

1.2 Function List

The following table lists the functions that can be used in the Modbus RTU communication.

Function	Description	Detailed explanation
Status monitor	Reads the items in "Display all", the monitor function of MR Configurator2, such as the servo motor speed and droop pulses.	Section 4.2
Parameter setting	Reads and writes data from/to parameters.	Section 4.3
Point table setting	Reads and writes point table data.	Section 4.4
Current alarm read	Reads alarm numbers that currently exist.	Section 4.7
Alarm history read	Reads the history of up to 16 alarms.	Section 4.9
Parameter error number read	Reads the parameter number at occurrence of a parameter error.	Section 4.11
Point table error number read	Reads the point table number at occurrence of a point table error.	Section 4.13
I/O monitor	Reads the ON/OFF state of external I/O signals and the status of the I/O devices	Section 4.14 Section 4.15 Section 4.16 Section 4.17
Servo amplifier information read	Reads the servo amplifier model and software version.	Section 4.18 Section 4.19
Motor drive	By accessing to holding registers which are assigned like the address assignment of CiA 402 drive profile, the servo motors are driven.	Chapter 5

1.3 Communication Specifications

The following table shows the communication specifications. For parameters, refer to chapter 2.

Item	Description	Remark	
Communication protocol	Modbus RTU protocol	When using, select the protocol with [Pr. PC71].	
Conformed standard	EIA-485 (RS-485)		
Number of connectable modules	1: n (up to 32 modules), Setting: Station 1 to station 247 (Station 0: Station number for the broadcast communication) Up to 32 modules including other slave devices such as inverters can be connected.	Set station numbers with [Pr. PC70].	
Communication baud rate [bps]	4800/9600/19200/38400/57600/115200	Select this item with [Pr. PC71].	
Control procedure	Asynchronous serial communication		
Communication method	Half duplex/Full duplex		
Communication specifications	Character method	Binary (fixed to 8 bits)	
	Start bit	1 bit	
	Stop bit length	Select from the following three types.	
	Parity check	<ul style="list-style-type: none"> • Even parity, stop bit length of 1 bit (Initial setting) • Odd parity, stop bit length of 1 bit • No parity, stop bit length of 2 bits 	Select this item with [Pr. PC71].
	Error check	CRC-16 method	
Terminator	None		
Waiting time setting	None		
Master/slave type	Slave		

The following shows a communication data format of 1 frame for Modbus RTU communication.

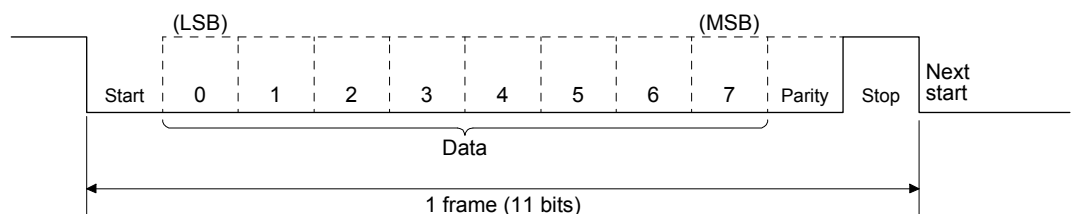

1. FUNCTIONS AND CONFIGURATION

1.4 System Configuration

1.4.1 Diagrammatic sketch

Up to 32 axes of servo amplifiers can be operated and controlled on one bus.

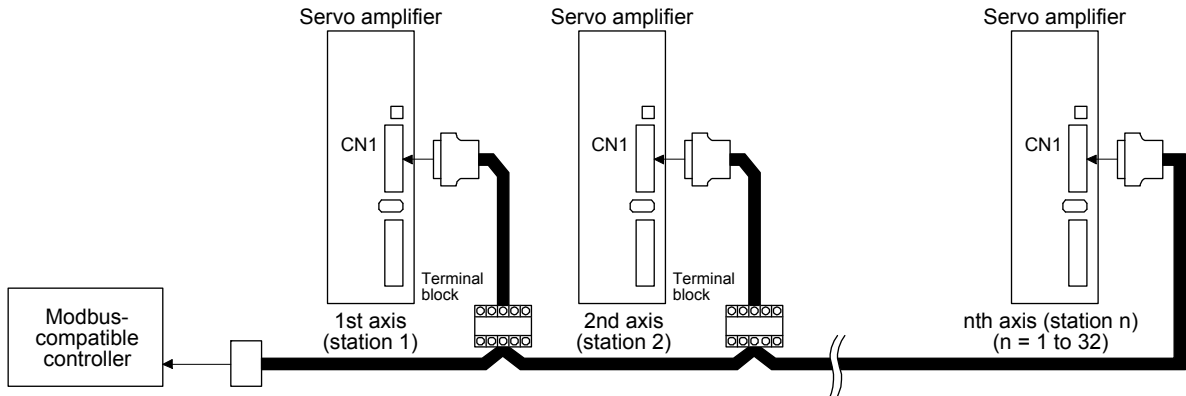

1. FUNCTIONS AND CONFIGURATION

1.4.2 Cable connection diagram

(1) Half duplex wiring

Wire the system as shown below.

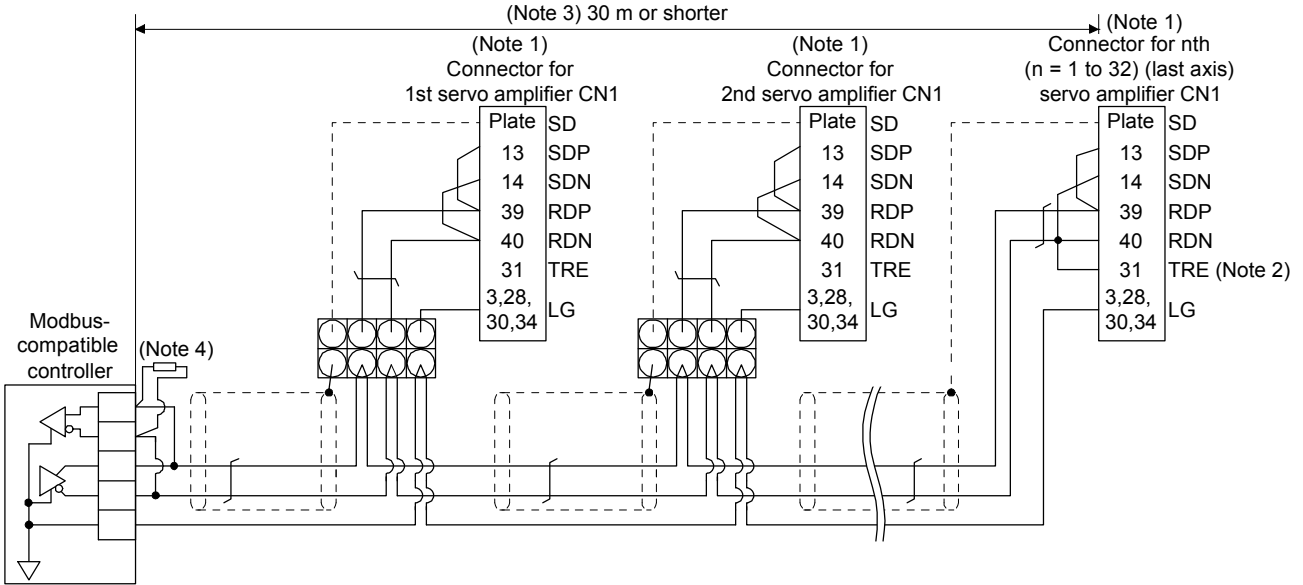

Note 1. Connector set MR-J3CN1 (3M or equivalent)

Connector: 10150-3000PE

Shell kit: 10350-52F0-008

2. Connect TRE and RDN on the last axis.

3. The total extension length should be 30 m or shorter in a low-noise environment.

4. When a Modbus-compatible controller does not have a termination resistor, terminate the wire ends with a register of 150 Ω.

(2) Full duplex wiring

Wire the system as shown below.

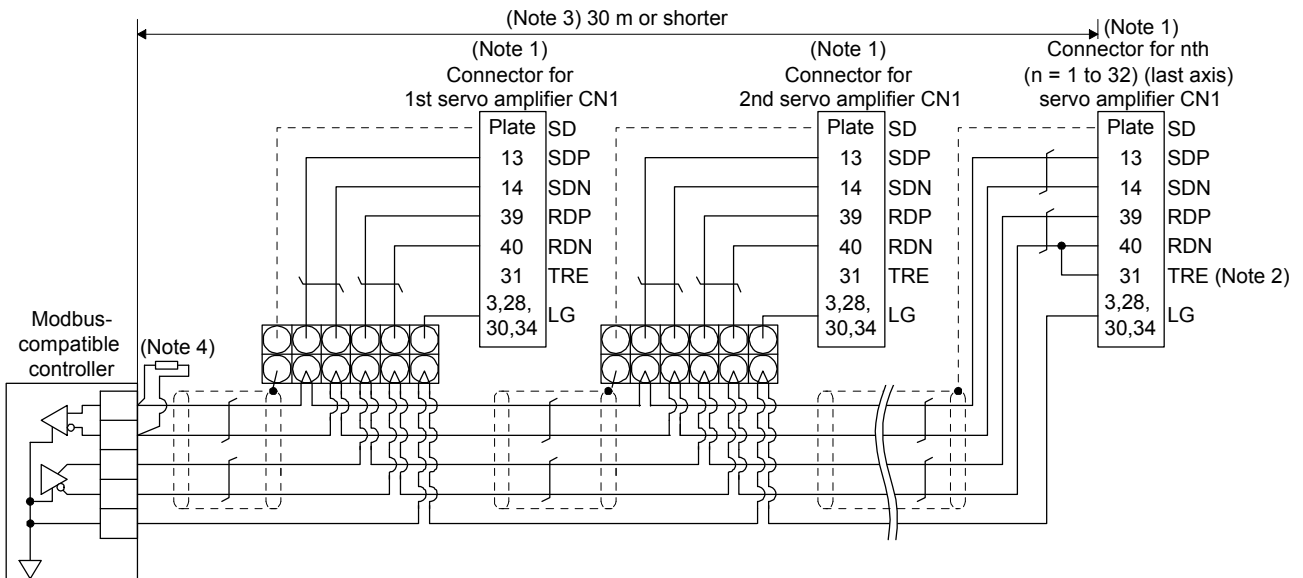

Note 1. Connector set MR-J3CN1 (3M or equivalent)

Connector: 10150-3000PE

Shell kit: 10350-52F0-008

2. Connect TRE and RDN on the last axis.

3. The total extension length should be 30 m or shorter in a low-noise environment.

4. When a Modbus-compatible controller does not have a termination resistor, terminate the wire ends with a register of 150 Ω.

2. PARAMETER

2. PARAMETER

CAUTION

- Never make a drastic adjustment or change to the parameter values as doing so will make the operation unstable.
- Do not change the parameter settings as described below. Doing so may cause an unexpected condition, such as failing to start up the servo amplifier.
 - Changing the values of the parameters for manufacturer setting
 - Setting a value out of the range
 - Changing the fixed values in the digits of a parameter

This chapter describes the parameters used for the communication with the MR-JE-_A servo amplifiers using the Modbus RTU communication protocol. Refer to "MELSERVO-JE-_A Servo Amplifier Instruction Manual" and "MELSERVO-JE-_A Servo Amplifier Instruction Manual (Positioning Mode)" for the items not given in this chapter.

POINT

- To enable a parameter whose symbol is preceded by *, turn off and on the power after setting a value.
- The symbols in the control mode column mean as follows.
 - P: Position control mode
 - S: Speed control mode
 - T: Torque control mode
 - CP: Positioning mode (point table method)
 - CL: Positioning mode (program method)
- Setting a value out of the setting range in each parameter will trigger [AL. 37 Parameter error].
- Set a value to each "x" in the "Setting digit" columns.

2. PARAMETER

2.1 Detailed list of parameters

(1) Extension setting parameters ([Pr. PC__])

No./Symbol/Name	Setting digit	Function	Initial value [unit]	Control mode				
				P	S	T	CP	CL
PC70 *SNOM Modbus RTU communication station number setting		Set a station number for the Modbus RTU communication. The station number "0" does not send a response data to the master (controller). When a response from a slave (servo amplifier) is required, set a value other than "0". Setting range: 0 to 247	0	<input type="radio"/>	<input type="radio"/>	<input type="radio"/>	<input type="radio"/>	<input type="radio"/>
PC71 *COPF Function selection C-F	___x	Communication protocol selection Select the communication protocol used. 0: RS-422/RS-485 communication (Mitsubishi Electric general-purpose AC servo protocol) 1: Modbus RTU protocol To perform the Modbus RTU communication, select "1". Set "Modbus RTU communication Input device selection" in [Pr. PC71] suitable for your usage. (Refer to table 2.1.)	0h	<input type="radio"/>	<input type="radio"/>	<input type="radio"/>	<input type="radio"/>	<input type="radio"/>
	__x_	Modbus RTU communication baud rate selection 0: 9600 [bps] 1: 19200 [bps] 2: 38400 [bps] 3: 57600 [bps] 4: 115200 [bps] 6: 4800 [bps]	4h	<input type="radio"/>	<input type="radio"/>	<input type="radio"/>	<input type="radio"/>	<input type="radio"/>
	_x__	Modbus RTU communication Input device selection Select input devices for the Modbus RTU communication. Refer to table 2.1 for details. 0: Operating input devices via the Modbus RTU communication 1: Operating input devices via DI When driving a motor using a Modbus register, set "0".	0h	<input type="radio"/>	<input type="radio"/>	<input type="radio"/>	<input type="radio"/>	<input type="radio"/>
	x___	Control switching method selection Select a control switching method. 0: Automatic selection 1: Input device (LOP (control switching)) 2: Modbus register (6060h) When "0" is selected for this digit, the control switching method is selected according to "Modbus RTU communication Input device selection" in [Pr. PC71] as follows. <ul style="list-style-type: none"> ▪ When "Operating input devices via DI (_ 1 __)" is selected: LOP (Control switching) ▪ When "Operating input devices via the Modbus RTU communication (_ 0 __)" is selected: Modbus register (6060h) 	0h	<input type="radio"/>	<input type="radio"/>	<input type="radio"/>	<input type="radio"/>	<input type="radio"/>

2. PARAMETER

No./Symbol/Name	Setting digit	Function	Initial value [unit]	Control mode																		
				P	S	T	CP	CL														
PC71 *COPF Function selection C-F	Table 2.1 Setting of [Pr. PC71] for the Modbus RTU communication																					
	<table border="1" style="width: 100%; border-collapse: collapse;"> <thead> <tr> <th rowspan="2" style="width: 40%;">[Pr. PA01]</th> <th colspan="2">Modbus RTU communication</th> </tr> <tr> <th style="width: 30%;">For operating input devices via DI</th> <th style="width: 30%;">For operating input devices via the Modbus RTU communication</th> </tr> </thead> <tbody> <tr> <td>___ 0 (Position control mode)</td> <td rowspan="8" style="text-align: center; vertical-align: middle;">_ 1 _ 1 (Note 1)</td> <td rowspan="6" style="text-align: center; vertical-align: middle;">Unavailable</td> </tr> <tr> <td>___ 1 (Position control mode and speed control mode)</td> </tr> <tr> <td>___ 2 (Speed control mode)</td> </tr> <tr> <td>___ 3 (Speed control mode and torque control mode)</td> </tr> <tr> <td>___ 4 (Torque control mode)</td> </tr> <tr> <td>___ 5 (Torque control mode and position control mode)</td> </tr> <tr> <td>___ 6 (Positioning mode (point table method))</td> <td rowspan="2" style="text-align: center; vertical-align: middle;">_ 0 _ 1 (Note 2)</td> </tr> <tr> <td>___ 7 (Positioning mode (program method))</td> </tr> </tbody> </table> <p>Note 1. Refer to section 2.2 (1) for the restrictions on operating input devices via DI. Note 2. Refer to section 2.2 (2) for the restrictions on operating input devices via the Modbus RTU communication.</p>							[Pr. PA01]	Modbus RTU communication		For operating input devices via DI	For operating input devices via the Modbus RTU communication	___ 0 (Position control mode)	_ 1 _ 1 (Note 1)	Unavailable	___ 1 (Position control mode and speed control mode)	___ 2 (Speed control mode)	___ 3 (Speed control mode and torque control mode)	___ 4 (Torque control mode)	___ 5 (Torque control mode and position control mode)	___ 6 (Positioning mode (point table method))	_ 0 _ 1 (Note 2)
[Pr. PA01]	Modbus RTU communication																					
	For operating input devices via DI	For operating input devices via the Modbus RTU communication																				
___ 0 (Position control mode)	_ 1 _ 1 (Note 1)	Unavailable																				
___ 1 (Position control mode and speed control mode)																						
___ 2 (Speed control mode)																						
___ 3 (Speed control mode and torque control mode)																						
___ 4 (Torque control mode)																						
___ 5 (Torque control mode and position control mode)																						
___ 6 (Positioning mode (point table method))		_ 0 _ 1 (Note 2)																				
___ 7 (Positioning mode (program method))																						
PC72 *COPG Function selection C-G	___ x	Modbus RTU communication Communication endian selection 0: Standard endian 1: Big endian Endian indicates the order of data with the unit of 2 bytes. For example, the following shows the order of 4-byte data "12345678h". 0 (Standard endian): 56781234 1 (Big endian): 12345678	0h	<input type="radio"/>	<input type="radio"/>	<input type="radio"/>	<input type="radio"/>	<input type="radio"/>														
	__ x _	For manufacturer setting	0h	<input type="checkbox"/>	<input type="checkbox"/>	<input type="checkbox"/>	<input type="checkbox"/>	<input type="checkbox"/>														
	_ x _ _		0h	<input type="checkbox"/>	<input type="checkbox"/>	<input type="checkbox"/>	<input type="checkbox"/>	<input type="checkbox"/>														
	x _ _ _		0h	<input type="checkbox"/>	<input type="checkbox"/>	<input type="checkbox"/>	<input type="checkbox"/>	<input type="checkbox"/>														

2. PARAMETER

(2) Extension setting 3 parameters ([Pr. PF__])

No./Symbol/Name	Setting digit	Function	Initial value [unit]	Control mode				
				P	S	T	CP	CL
PF45 *FOP12 Function selection F-12	___x	Modbus RTU communication Parity selection 0: Even parity, stop bit length of 1 bit 1: Odd parity, stop bit length of 1 bit 2: No parity, stop bit length of 2 bits	0h	<input type="radio"/>	<input type="radio"/>	<input type="radio"/>	<input type="radio"/>	<input type="radio"/>
	__x_	For manufacturer setting	0h	<input type="checkbox"/>	<input type="checkbox"/>	<input type="checkbox"/>	<input type="checkbox"/>	<input type="checkbox"/>
	_x__		0h	<input type="checkbox"/>	<input type="checkbox"/>	<input type="checkbox"/>	<input type="checkbox"/>	<input type="checkbox"/>
	x___		0h	<input type="checkbox"/>	<input type="checkbox"/>	<input type="checkbox"/>	<input type="checkbox"/>	<input type="checkbox"/>
PF46 MIC Modbus RTU communication time out selection		Set the communication timeout time in the Modbus RTU communication. When "0" is set, communication timeout is not checked. Setting range: 0 to 60	0 [s]	<input type="radio"/>	<input type="radio"/>	<input type="radio"/>	<input type="radio"/>	<input type="radio"/>

(3) Positioning control parameters ([Pr. PT__])

No./symbol/name	Setting digit	Function	Initial value [Unit]	Control mode				
				P	S	T	CP	CL
PT45 *CZTY Home position return type 2	__xx	Home position return method 2 Set the home position return method. 00: Home position return set in the first digit of [Pr. PT04] is enabled. 07: Home position neighborhood input and home position signal type (forward rotation) (Homing on home switch and index pulse) 08: Home position neighborhood input and home position signal type (forward rotation) (Homing on home switch and index pulse) 0B: Home position neighborhood input and home position signal type (reverse rotation) (Homing on home switch and index pulse) 0C: Home position neighborhood input and home position signal type (reverse rotation) (Homing on home switch and index pulse) 17: Home position non-signal type (forward rotation) (Homing without index pulse) 1B: Home position non-signal type (reverse rotation) (Homing without index pulse) 23: Current position type (Homing on current position) 25: Current position type (Homing on current position)	00h	<input type="checkbox"/>	<input type="checkbox"/>	<input type="checkbox"/>	<input type="radio"/>	<input type="radio"/>
	_x__	For manufacturer setting	0h	<input type="checkbox"/>	<input type="checkbox"/>	<input type="checkbox"/>	<input type="checkbox"/>	<input type="checkbox"/>
	x___		0h	<input type="checkbox"/>	<input type="checkbox"/>	<input type="checkbox"/>	<input type="checkbox"/>	<input type="checkbox"/>

2. PARAMETER

2.2 Restrictions on using Modbus RTU communication

(1) Restrictions on operating input devices via DI

When the input devices are operated via DI ([Pr. PC71]: _ 1 _ 1), the Modbus registers shown in table 2.2 cannot be used in the Modbus RTU communication.

Table 2.2 Unusable registers when the input devices are operated via DI

Address	Modbus register
6040h	Control command
6081h	Command speed
2D01h to 2D09h	Control input
2D60h	Point table specification
2D70h	Program number specification
2D9Ah	Simultaneous start bit setting
2DB0h	Override
60E0h	Forward rotation torque limit
60E1h	Reverse rotation torque limit

(2) Restrictions on operating input devices via the Modbus RTU communication

When the input devices are operated via the Modbus RTU communication ([Pr. PC71]: _ 0 _ 1), the Modbus registers shown in table 2.2 can be used. However, only the input devices shown in table 2.3 can be used via DI.

Table 2.3 Input devices which can be used via DI

Device name	Symbol
Forward rotation stroke end	LSP
Reverse rotation stroke end	LSN
Proximity dog	DOG
Mark detection	MSD
Forced stop 2/Forced stop 1	EM2/EM1
Program input 1	PI1
Program input 2	PI2
Program input 3	PI3
Current position latch input	LPS
Clutch command	CLTC (Note)
Cam position compensation request	CPCD (Note)

Note. This is available with servo amplifiers with software version C1 or later.

3. MODBUS PROTOCOL

3. MODBUS PROTOCOL

3.1 Modbus RTU Message Format

In the Modbus RTU communication, a command sent from a master (controller) to a slave (servo amplifier) is called "Query Message", and a command that the slave (servo amplifier) returns to the master (controller) is called "Response Message".

The servo amplifier that received a Query Message processes the command only after it passes through a dataless section of 3.5 bytes or larger. The servo amplifier will send a Response Message to the controller after the servo amplifier's response time has passed. When the controller sent a Query Message without securing a dataless section of 3.5 bytes or larger, the servo amplifier does not respond. Execute processing so that the controller sends the next Query Message only after it receives a Response Message sent from the servo amplifier.

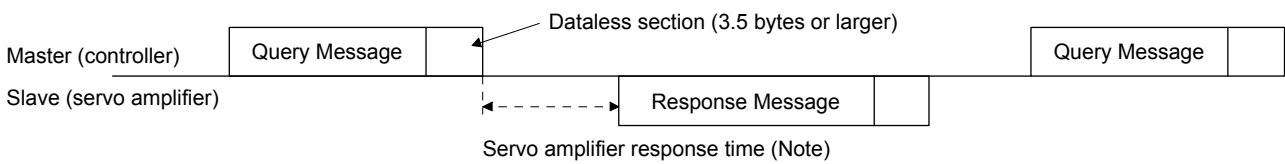

Note. The servo amplifier response time differs depending on the command to send.

3.2 Broadcast Communication

The Modbus RTU communication supports the broadcast communication in which a Query Message is sent from the master (controller) to all slaves (all axes of servo amplifiers). In this case, the servo amplifiers do not return a Response Message. Execute processing so that the master sends the next Query Message after the slave processing time has passed. The broadcast communication supports only the function code: "10h" (Preset Multiple Registers).

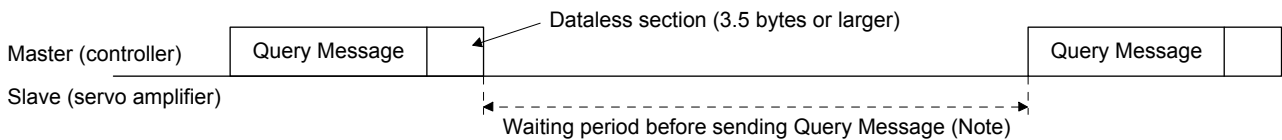

Note. The waiting period before sending Query Message varies depending on a command to be sent. Refer to the following table.

Condition	No. of Registers (Number of registers to write)	Waiting time for sending query message
For writing data of 4 bytes	2	12 [ms]
For writing data of 244 bytes	122	300 [ms]

3. MODBUS PROTOCOL

3.3 Modbus RTU Communication Message Frame

Query Messages sent from the master (controller) and Response Messages sent from the slaves (servo amplifiers) are both sent in the following message frame format.

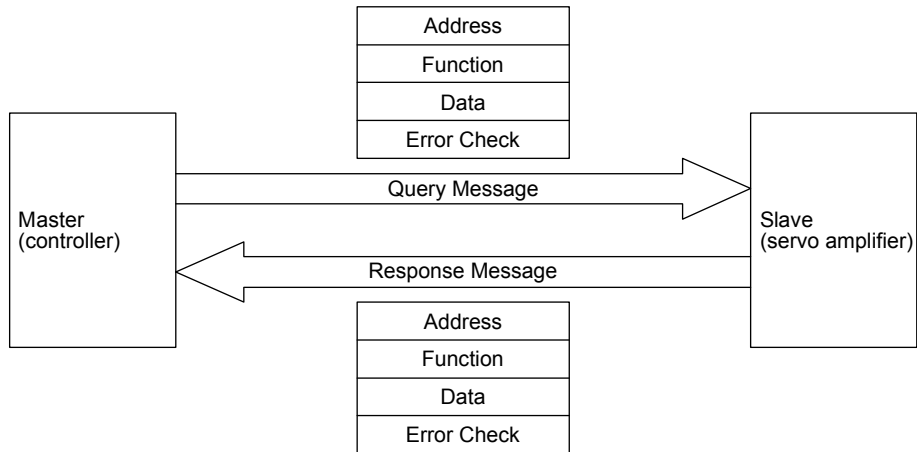

A message frame is composed of four message fields.

When a slave (servo amplifier) received a Query Message sent from the master (controller) without errors, the Function Code in the Query Message is copied into the Function in a Response Message. When a slave (servo amplifier) received a Query Message with an error, the slave returns a value obtained by adding "80h" to the Function Code value in the Query Message to the master. Judge the occurrence of an error by checking the Function Code in the Response Message on the controller side.

During the dataless time of 3.5 bytes before and after the reception of a Query Message, the servo amplifier recognizes the received Query Message.

Message frame

START	Address	Function	Data	Error Check		END
				L	H	
3.5 bytes	8 bits	8 bits	n × 8 bits	8 bits	8 bits	3.5 bytes

Message field	Size	Communication path	Description
Address	8 bits	Master → Slave	Set a station number. Set a value within 0 to 247 with 1-byte length (8 bits). When 0 is set, the broadcast communication is executed.
		Slave → Master	The station number of a slave (servo amplifier) is returned.
Function	8 bits	Master → Slave	Set a function code. Set a function code to request to the slave.
		Slave → Master	Send the function code requested by the master. When a communication error has occurred, send a value obtained by adding "80h" to the function code requested by the master.
Data	n × 8 bits	Master → Slave	The format changes depending on the function code selected.
		Slave → Master	Refer to section 3.4 for details.
Error Check	16 bits	Master → Slave	Send data to perform the CRC check of a received message frame.
		Slave → Master	

3. MODBUS PROTOCOL

3.4 Function Codes

3.4.1 List of function codes

The MR-JE-__A servo amplifier supports the following function codes.

Code	Function name	Description	Broadcast communication
03h	Read Holding Registers	Reading data in holding registers The data in the registered holding registers can be read from the master.	Not supported
08h	Diagnostics	Function diagnostics When this function code is sent from the master to a slave, the slave returns the received data to the master without any changes. Communication checks can be performed.	Not supported
10h	Preset Multiple Registers	Writing data in multiple holding registers Continuous multiple data sets can be written in the registered holding registers from the master.	Supported

3. MODBUS PROTOCOL

3.4.2 Read Holding Registers (Reading data in holding registers: 03h)

Data in consecutive registers is read for the specified number of data points starting from the specified register address.

(1) Message frame

Query Message

Slave Address	Function	Starting Address		No. of Points		CRC Check	
		H	L	H	L	L	H
(8 bits)	03h	(8 bits)	(8 bits)	(8 bits)	(8 bits)	(8 bits)	(8 bits)

Message	Size	Description
Slave Address	8 bits	Set a station number to which the message is sent. The number "0" (station number for broadcast sending) cannot be set.
Function	8 bits	Set "03h".
Starting Address (Note 2)	16 bits	Set a start address of the holding registers to read.
No. of Points	16 bits	Set the number of points of data to read starting from the start address of the holding registers from which data is read. Set the number of read points described in the list of holding registers. To read the data in continuous registers, set a value obtained by adding the number of read points of the target registers to this number.
CRC Check	16 bits	Data for CRC error check This data is calculated automatically by a controller.

Response Message

Slave Address	Function	Byte Count	Data					CRC Check	
			H	L	to	H	L	L	H
(8 bits)	(8 bits)	(8 bits)	(8 bits)	(8 bits)	to	(8 bits)	(8 bits)	(8 bits)	(8 bits)

Message	Size	Description
Slave Address	8 bits	The station number of a slave (servo amplifier) is returned.
Function	8 bits	When the message was received without errors, "03h" is returned.
Byte Count	8 bits	The Data frame size (in units of bytes) is returned. A value obtained by multiplying the value set for No. of Points in the Query Message by 2 is returned.
Data (Note 1)	16 bits × n	Data starting from the start address specified in the Query Message is returned. Data is read in order of H (higher bits) and L (lower bits). Data is read in order starting from the start address.
CRC Check	16 bits	Data for CRC error check This data is calculated automatically by a servo amplifier, and the result of the calculation is returned.

- Note
- Higher 8 bits of 1-byte data are set to "00h" when this data is returned. To use the signed 1-byte data as 2-byte data, perform sign extension on the master (controller) side.
 - Registers can be classified into two types: registers that can be continuously accessed and particular registers that cannot be continuously accessed.
To read particular registers, read only the target registers.
For the details on whether the target registers can be continuously accessed or not, refer to the directions for use of each function of the Modbus registers described in chapter 4.

3. MODBUS PROTOCOL

(2) Usage example

The following shows a setting example of when Modbus registers 2B05h (Command pulse frequency) to 2B07h (Analog torque limit voltage) in the slave address "02" are read.

Index	Name	Data type	Read/write	No. of Points (Number of read points)	Continuous read/write	Register value (Read data)
2B05h	Command pulse frequency	4 bytes	Read	2	○	12345678h
2B06h	Analog speed command voltage Analog speed limit voltage	2 bytes	Read	1	○	1000h
2B07h	Analog torque limit voltage Analog torque command voltage	2 bytes	Read	1	○	2000h

Query Message

Slave Address	Function	Starting Address		No. of Points		CRC Check	
		H	L	H	L	L	H
02h	03h	2Bh	05h	00h	04h	(8 bits)	(8 bits)

Set the following values to each Query Message.

Message	Description
Slave Address	Set the station number "02h".
Function	Set "03h".
Starting Address	Set "2B05h", the start address to read.
No. of Points	Set "04h", because the total number of read points from Modbus registers 2B05h to 2B07h is 4.
CRC Check	Data for CRC error check This data is calculated automatically by a controller.

Response Message

Slave Address	Function	Byte Count	Data								CRC Check	
			H	L	H	L	H	L	H	L	L	H
02h	03h	08h	56h	78h	12h	34h	10h	00h	20h	00h	(8 bits)	(8 bits)

The following shows the information in each Response Message.

Message	Description
Slave Address	The station number "02h" is returned.
Function	The value "03h" is returned. This means that the message was received without errors.
Byte Count	The value "08h" is returned. This means that data of 8 frames is returned.
Data	Data starting from the start address is returned. Lower-bit value of the register 2B05h: "5678h" Higher-bit value of the register 2B05h: "1234h" Value of the register 2B06h: "1000h" Value of the register 2B07h: "2000h" The endian setting of 4-byte data can be configured using [Pr. PC72]. This example shows the case when the standard endian (initial value) is set.
CRC Check	Data for CRC error check This data is calculated automatically by a servo amplifier, and the result of the calculation is returned.

3. MODBUS PROTOCOL

3.4.3 Diagnostics (Function diagnostics: 08h)

Use this register when performing the communication check from the master (controller). When a slave (servo amplifier) received a Query Message, the slave sends the received data as a Response Message without any changes to the master (controller).

(1) Message frame

Query Message

Slave Address	Function	Sub Function		Data		CRC Check	
		H	L	H	L	L	H
(8 bits)	08h	00h	00h	(8 bits)	(8 bits)	(8 bits)	(8 bits)

Message	Size	Description
Slave Address	8 bits	Set a station number to which the message is sent. The number "0" (station number for broadcast sending) cannot be set.
Function	8 bits	Set "08h".
Sub Function	16 bits	Set "0000h". When a value other than "0000h" is set, a communication error occurs.
Data	16 bits	Set 2-byte length data.
CRC Check	16 bits	Data for CRC error check This data is calculated automatically by a controller.

Response Message

Slave Address	Function	Sub Function		Data		CRC Check	
		H	L	H	L	L	H
(8 bits)	08h	00h	00h	(8 bits)	(8 bits)	(8 bits)	(8 bits)

Message	Size	Description
Slave Address	8 bits	The station number of a slave (servo amplifier) is returned.
Function	8 bits	When the Query Message was received without errors, "08h" is returned.
Sub Function	16 bits	The value "0000h" is returned.
Data	16 bits	The data set in the Query Message is returned.
CRC Check	16 bits	Data for CRC error check This data is calculated automatically by a servo amplifier, and the result of the calculation is returned.

3. MODBUS PROTOCOL

(2) Usage example

The following shows a setting example of when the function diagnostics of the slave address "03h" is executed.

Query Message

Slave Address	Function	Sub Function		Data		CRC Check	
		H	L	H	L	L	H
03h	08h	00h	00h	12h	34h	(8 bits)	(8 bits)

Set the following values to each Query Message.

Message	Description
Slave Address	Set the station number "03h".
Function	Set "08h".
Sub Function	Set "0000h".
Data	When setting 1234h, set values as follows: H: "12h" L: "34h"
CRC Check	Data for CRC error check This data is calculated automatically by a controller.

Response Message

Slave Address	Function	Sub Function		Data		CRC Check	
		H	L	H	L	L	H
03h	08h	00h	00h	12h	34h	(8 bits)	(8 bits)

The following shows the information in each Response Message.

Message	Description
Slave Address	The station number "03h" is returned.
Function	The value "08h" is returned. This means that the message was received without errors.
Sub Function	The value "0000h" is returned.
Data	The value "1234h" set in the Query Message is returned. H: "12h" L: "34h"
CRC Check	Data for CRC error check This data is calculated automatically by a servo amplifier, and the result of the calculation is returned.

3. MODBUS PROTOCOL

3.4.4 Preset Multiple Registers (Writing data in multiple holding registers: 10h)

Data is written to consecutive holding registers for the specified number of data points starting from the specified register address.

(1) Message frame

Query Message

Slave Address	Function	Starting Address		No. of Registers		Byte Count	Data					CRC Check	
		H	L	H	L		H	L	to	H	L	L	H
(8 bits)	10h	(8 bits)	(8 bits)	(8 bits)	(8 bits)	(8 bits)	(8 bits)	(8 bits)	to	(8 bits)	(8 bits)	(8 bits)	(8 bits)

Message	Size	Description
Slave Address	8 bits	Set a station number to which the message is sent. When "0" (station number for broadcast sending) is set, this message is sent to all axes. (Note 1)
Function	8 bits	Set "10h".
Starting Address (Note 2)	16 bits	Set the start address of the holding registers to which data is written.
No. of Registers	16 bits	Set the number of points of data to write starting from the start address of the holding registers to which data is written. Set the number of write points described in the list of holding registers. To write data in continuous registers, set a value obtained by adding the number of write points of the target registers to this number.
Byte Count	8 bits	Set the size of the data to write.
Data (Note 2)	16 bits × n	Set the data to write.
CRC Check	16 bits	Data for CRC error check This data is calculated automatically by a controller.

Response Message

Slave Address	Function	Starting Address		No. of Registers		CRC Check	
		H	L	H	L	L	H
(8 bits)	10h	(8 bits)	(8 bits)	(8 bits)	(8 bits)	(8 bits)	(8 bits)

Message	Size	Description
Slave Address	8 bits	The station number of a slave (servo amplifier) is returned.
Function	8 bits	When the Query Message was received without errors, "10h" is returned.
Starting Address	16 bits	The start address of the holding registers to which the data was written is returned.
No. of Registers	16 bits	The number of points of written data starting from the start address of the holding registers to which the data was written is returned.
CRC Check	16 bits	Data for CRC error check This data is calculated automatically by a servo amplifier, and the result of the calculation is returned.

- Note
1. When the broadcast communication was performed, a Response Message is not returned from the slave. To send the next Query Message continuously, send it considering the processing time of the slave.
 2. Registers can be classified into two types: registers to which data can be continuously written and particular registers to which data cannot be continuously written.
To write data in particular registers, write data in the target registers one by one.
For the details on whether data can be continuously written into the target registers or not, refer to chapter 4.

3. MODBUS PROTOCOL

(2) Usage example

The following shows a setting example for writing "0100h" in the Modbus register 2102h ([Pr. PC02]) of the slave address "02h".

Index	Name	Data type	Read/write	No. of Registers (Number of registers to write)	Continuous read/write	Setting value
2102h	PC02	4 bytes	Read/write	2	○	00000100h

Query Message

Slave Address	Function	Starting Address		No. of Registers		Byte Count	Data				CRC Check		
		H	L	H	L		H	L	L	H			
02h	10h	21h	02h	00h	02h	04h	01h	00h	00h	00h	00h	(8 bits)	(8 bits)

Set the following values to each Query Message.

Message	Description
Slave Address	Set the station number "02h".
Function	Set "10h".
Starting Address	Set "2102h", the start address of the registers to which data is written.
No. of Registers	Set "02h", because the total number of write points of the Modbus register 2102h is 2.
Byte Count	Set "04h". This means that data of 4 frames is sent.
Data	Set values in order starting from the start address. Lower-bit value of the register 2102h: "0100h" Higher-bit value of the register 2102h: "0000h" The endian setting of 4-byte data can be configured using [Pr. PC72]. This example shows the case when the standard endian (initial value) is set.
CRC Check	Data for CRC error check This data is calculated automatically by a controller.

Response Message

Slave Address	Function	Starting Address		No. of Registers		CRC Check	
		H	L	H	L	L	H
02h	10h	21h	02h	00h	02h	(8 bits)	(8 bits)

The following shows the information in each Response Message.

Message	Description
Slave Address	The station number "02h" is returned.
Function	The value "10h" is returned. This means that the message was received without errors.
Starting Address	The value "2102h", the start address of the holding registers to which the data was written is returned. H: "21h" L: "02h"
No. of Registers	The number of registers to write "02h" is returned.
CRC Check	Data for CRC error check This data is calculated automatically by a servo amplifier, and the result of the calculation is returned.

3. MODBUS PROTOCOL

3.4.5 Processing at occurrence of an error

In the Modbus RTU communication, when the Query Message sent from the master (controller) includes an incorrect value, the slave (servo amplifier) returns an exception response to the master (controller).

When a parity error, CRC error, overrun error, or framing error occurs, the slave (servo amplifier) does not return a message to the master (controller).

When an exception response occurs, a value obtained by adding "80h" to the function code sent in the Query Message is returned with an exception code.

However, no exception response occurs in the following cases.

- When the function code "03h" (Read Holding Registers) is used
When data can be read from even one of continuous registers, no exception response occurs. In this case, "0" is returned to the register data that cannot be read.
- When the function code "10h" (Preset Multiple Registers) is used
When data can be written into even one of continuous registers, no exception response occurs.

The following shows the Response Message to be sent at occurrence of an exception response.

Response Message

Slave Address	Function	Exception Code	CRC Check	
			L	H
(8 bits)	(8 bits)	(8 bits)	(8 bits)	(8 bits)

Message	Size	Description
Slave Address	8 bits	The station number of a slave (servo amplifier) is returned.
Function	8 bits	A value obtained by adding "80h" to the function code of the Query Message is returned. When Function is "03h": "83h" When Function is "08h": "88h" When Function is "10h": "90h" When an unsupported Function (example: "01h") is used, "Function + 80h" (example: "81h") is returned.
Exception Code	8 bits	An exception code is set. For details of exception codes, refer to the following "List of exception codes".
CRC Check	16 bits	Data for CRC error check This data is calculated automatically by a servo amplifier, and the result of the calculation is returned.

List of exception codes

Code	Error name	Description
01h	ILLEGAL FUNCTION	The Query Message sent from the master set a function code that the slave does not support.
02h	ILLEGAL DATA ADDRESS	The Query Message sent from the master set a register address that the slave does not support. (Ex: No register address is set, or reading or writing data from/to registers is not available.)
03h	ILLEGAL DATA VALUE	The Query Message sent from the master set data that the register cannot handle. (Ex: A value out of the setting range is set, or "0" is set to No. of Registers.)

When an exception code is generated, a CRC error may occur at the same time.

4. MODBUS REGISTERS

4. MODBUS REGISTERS

POINT

● For details on the registers for driving a motor, refer to chapter 5.

4.1 List of Available Registers

By reading and writing data in the registers that are compatible with the Modbus RTU communication, the following functions can be performed using the MR-JE-_A servo amplifier.

Function	Description	Reference
Monitor	Each status in the servo amplifier can be monitored.	Section 4.2
Parameter setting	Data can be read and written from/to parameters.	Section 4.3
Point table setting	Point table data can be read and written.	Section 4.4
Writing command to EEPROM	The set servo parameters and point table data can be saved in EEPROM.	Section 4.5
Alarm information	The alarm status of the servo amplifier can be read.	Section 4.6
Alarm number	The current alarm number can be read.	Section 4.7
Alarm occurrence monitor	Each monitor information at occurrence of an error can be read.	Section 4.8
Alarm history	The alarm history at occurrence of an error can be read.	Section 4.9
Alarm history clear	The history of alarms can be cleared.	Section 4.10
Parameter error count	The parameter error count can be read.	Section 4.11
Parameter error number	Parameter error numbers can be read.	Section 4.12
Point table error	Point table error numbers can be read.	Section 4.13
External input pin status	The ON/OFF state of the external input pins input to the servo amplifier can be read.	Section 4.14
External output pin status	The ON/OFF state of external output pins output from the servo amplifier can be read.	Section 4.15
Input device status	The current input device status can be read.	Section 4.16
Output device status	The current output device status can be read.	Section 4.17
Servo amplifier model	The model name of the currently-connected servo amplifier can be read.	Section 4.18
Servo amplifier software version	The software version of the currently connected servo amplifier can be read.	Section 4.19
Broadcast setting	The disabling setting of the broadcast communication of the Modbus RTU communication can be configured.	Section 4.20
Servo motor rated speed	The servo motor rated speed can be read.	Section 4.21
Servo motor maximum speed	The servo motor maximum speed can be read.	Section 4.22
SDO Abort Code	The SDO Abort Code that is currently occurring can be read.	Section 4.23
Access log 1	The access log 1 can be read.	Section 4.24
Access log 2	The access log 2 can be read.	Section 4.25
Communication error count	The Modbus RTU communication error count can be read.	Section 4.26
Supported profile information	The supported profile information can be read.	Section 4.27
Device information	The device information can be read.	Section 4.28

4. MODBUS REGISTERS

4.2 Monitor (Address: 2B01h to 2B7Fh)

Each status in the servo amplifier can be monitored. For the items that can be monitored, refer to the list of registers.

4.2.1 List of registers

The following items can be monitored. Refer to "MELSERVO-JE-_A Servo Amplifier Instruction Manual" and "MELSERVO-JE-_A Servo Amplifier Instruction Manual (Positioning Mode)" for each of the following items.

Address	Name	Unit	Data type	Read/write	No. of points/ No. of registers	Continuous read/ continuous write
2B01h	Cumulative feedback pulses	pulse	4 bytes	Read	2	Possible
2B02h	Servo motor speed	r/min	4 bytes	Read	2	Possible
2B03h	Droop pulses	pulse	4 bytes	Read	2	Possible
2B04h	Cumulative command pulses	pulse	4 bytes	Read	2	Possible
2B05h	Command pulse frequency	kpulse/s	4 bytes	Read	2	Possible
2B06h	Analog speed command voltage Analog speed limit voltage	0.01 V	2 bytes	Read	1	Possible
2B07h	Analog torque limit voltage Analog torque command voltage	0.01 V	2 bytes	Read	1	Possible
2B08h	Regenerative load ratio	%	2 bytes	Read	1	Possible
2B09h	Effective load ratio	%	2 bytes	Read	1	Possible
2B0Ah	Peak load ratio	%	2 bytes	Read	1	Possible
2B0Bh	Instantaneous torque	%	2 bytes	Read	1	Possible
2B0Ch	Position within one-revolution	pulse	4 bytes	Read	2	Possible
2B0Dh	ABS counter	rev	4 bytes	Read	2	Possible
2B0Eh	Load to motor inertia ratio	0.01 times	2 bytes	Read	1	Possible
2B0Fh	Bus voltage	V	2 bytes	Read	1	Possible
2B10h to 2B24h	Reserved					
2B25h	Encoder inside temperature	°C	2 bytes	Read	1	Possible
2B26h	Settling time	ms	2 bytes	Read	1	Possible
2B27h	Oscillation detection frequency	Hz	2 bytes	Read	1	Possible
2B28h	Number of tough operations	times	2 bytes	Read	1	Possible
2B29h	Reserved					
2B2Ah						
2B2Bh						
2B2Ch						
2B2Dh	Unit power consumption	W	2 bytes	Read	1	Possible
2B2Eh	Unit total power consumption	Wh	4 bytes	Read	2	Possible
2B2Fh	Current position	0.001 mm (Note 1)	4 bytes	Read	2	Possible
2B30h	Command position	0.001 mm (Note 1)	4 bytes	Read	2	Possible
2B31h	Remaining command distance	0.001 mm (Note 1)	4 bytes	Read	2	Possible
2B32h	Point table No./Program No.		2 bytes	Read	1	Possible
2B33h	Step No.		2 bytes	Read	1	Possible
2B34h	Override voltage	0.01 V	2 bytes	Read	1	Possible
2B35h	Override level	%	2 bytes	Read	1	Possible
2B36h	Reserved					
2B37h						
2B38h	Current position in one cycle of CAM axis	0.001 mm (Note 2)	4 bytes	Read	2	Possible
2B39h	Basis position of CAM	0.001 mm (Note 1)	4 bytes	Read	2	Possible

4. MODBUS REGISTERS

Address	Name	Unit	Data type	Read/write	No. of points/ No. of registers	Continuous read/ continuous write
2B3Ah	Feed current position of CAM	0.001 mm (Note 1)	4 bytes	Read	2	Possible
2B3Bh	CAM No.		2 bytes	Read	1	Possible
2B3Ch	Stroke movement of CAM	0.001 mm (Note 1)	4 bytes	Read	2	Possible
2B3Dh	Current position of main axis	0.001 mm (Note 2)	4 bytes	Read	2	Possible
2B3Eh	Current position in one cycle of main axis	0.001 mm (Note 2)	4 bytes	Read	2	Possible
2B3Fh to 2B7Fh	Reserved					

Note 1. The unit and magnification change depending on the setting values of [Pr. PT01] and [Pr. PT03].

2. The unit and magnification change depending on the setting values of [Pr. PT01] and [Pr. PT03], or the setting of [Cam control data No. 14].

4.2.2 Directions for use

Set the address of the item to be monitored using the function code "03h" (Read Holding Registers). The value of the specified monitor item is returned from the servo amplifier.

Data in these registers can be continuously read. Data in continuous registers can be read at once. An error occurs if the register for manufacturer setting.

4. MODBUS REGISTERS

4.3 Parameter Setting (Address: 2001h to 27FFh)

Data can be read and written from/to parameters.

4.3.1 List of registers

Data can be read and written from/to the following parameters. Refer to "MELSERVO-JE-_A Servo Amplifier Instruction Manual" and "MELSERVO-JE-_A Servo Amplifier Instruction Manual (Positioning Mode)" for the setting of each parameter.

Address	Name	Data type	Read/write	No. of points/ No. of registers	Continuous read/ continuous write
2001h to 2020h	PA01 to PA32	4 bytes	Read/write	2	Possible
2021h to 2080h	Reserved				
2081h to 20C0h	PB01 to PB64	4 bytes	Read/write	2	Possible
20C1h to 2100h	Reserved				
2101h to 2150h	PC01 to PC80	4 bytes	Read/write	2	Possible
2151h to 2180h	Reserved				
2181h to 21B0h	PD01 to PD48	4 bytes	Read/write	2	Possible
21B1h to 2200h	Reserved				
2201h to 2240h	PE01 to PE64	4 bytes	Read/write	2	Possible
2241h to 2280h	Reserved				
2281h to 22B0h	PF01 to PF48	4 bytes	Read/write	2	Possible
22B1h to 2480h	Reserved				
2481h to 24B0h	PT01 to PT48	4 bytes	Read/write	2	Possible
24B1h to 27FFh	Reserved				

4.3.2 Directions for use

Read the parameter values using the function code "03h" (Read Holding Registers). Write the parameter values using the function code "10h" (Preset Multiple Registers). Reading and writing of data from/to parameters depend on the setting of [Pr. PA19 Parameter writing inhibit].

Even though parameter setting values are changed with these registers, the set values are deleted at power-off if no setting for holding values is configured. To hold parameter setting values even after power-off, configure the setting to save the values in EEPROM using Store Parameters (Register: 1010h) after the parameter setting values are changed.

4. MODBUS REGISTERS

4.4 Point Table Setting (Address: 2801h to 281Fh)

Point table data can be read and written.

4.4.1 List of registers

Point table data can be read and written from/to the following registers. For details of point tables, refer to "MELSERVO-JE-_A Servo Amplifier Instruction Manual (Positioning Mode)".

Address	Name	Data type	Read/write	No. of points/ No. of registers	Continuous read/ continuous write	
2801h to 281Fh	Point Table No.1 to No.31 (Point table No.1 to No.31)	Number of entries (Note 1)	1 byte	Read/write	9	Impossible
		Point data	4 bytes			
		Speed	2 bytes			
		Acceleration	2 bytes			
		Deceleration	2 bytes			
		Dwell	2 bytes			
		Sub	1 byte			
		M code (Note 2)	1 byte			

Note 1. This item is enabled only at reading. At reading, "07h" is returned.

2. M code will be available in the future.

4.4.2 Directions for use

Read point table data using the function code "03h" (Read Holding Registers). At this time, "07h" is returned to Number of entries. Write point table data using the function code "10h" (Preset Multiple Registers). Set "00h" or "07h" for Number of entries. Reading and writing of the point table data are executed by each point table number. Thus, changing only position data of the particular point table number cannot be performed. In that case, overwrite all the setting data values of the particular point table number with new data.

Data cannot be continuously read and written from/to these registers. Set values for each point table number.

Even though setting values are changed with these registers, the set values are deleted at power-off if no setting for holding values is configured. To hold setting values even after power-off, configure the setting to save the values in EEPROM using Store Parameters (Register: 1010h) after the setting values are changed.

4.5 Writing Command to EEPROM (Address: 1010h)

Parameter and point table setting values can be saved in EEPROM.

4.5.1 List of registers

Address	Name	Data type	Read/write	No. of points/ No. of registers	Continuous read/ continuous write	
1010h	Store Parameters	Number of entries	1 byte	Read/write	11	Impossible
		Save all parameters	4 bytes			
		Save communication Parameters	4 bytes			
		Save application Parameters	4 bytes			
		Save manufacturer defined parameters	4 bytes			
		Save Point table	4 bytes			

4. MODBUS REGISTERS

4.5.2 Directions for use

Using the function code "03h" (Read Holding Registers) reads the information that shows whether each command can be used or not. The following table shows the returned values of each item.

Item	Saved parameter	Returned value
Number of entries		05h
Save all parameters	Address: 2001h to 27FFh Address: 2801h to 281Fh	00000001h (Supported)
Save communication parameters	Address: 1000h to 1FFFh	00000000h (Unsupported)
Save application Parameters	Address: 2001h to 27FFh Address: 2801h to 281Fh	00000001h (Supported)
Save manufacturer defined parameters	Address: 2001h to 27FFh	00000001h (Supported)
Save Point table	Address: 2801h to 281Fh	00000001h (Supported)

Select the items to be saved in EEP-ROM using the function code "10h" (Preset Multiple Registers). At this time, set "00h" or "05h" for Number of entries.

To save servo amplifier parameters and point table data in EEP-ROM, configure required settings following the table below. When bit 1 (EEP-ROM write completed) of the control output (register: 2D11h) is "1", saving data in EEP-ROM has been completed.

Writing a value other than "65766173h" and "00000000h" to each item results in an error.

Item	Setting value	Write to EEP-ROM	
		Parameter	Point table
Number of entries	05h		
Save all parameters	00000000h	Invalid	Invalid
	65766173h ("save")	Valid	Valid
	Other than the values above	Error	Error
Save communication parameters	00000000h	Invalid	Invalid
	65766173h ("save")	Invalid	Invalid
	Other than the values above	Error	Error
Save application Parameters	00000000h	Invalid	Invalid
	65766173h ("save")	Valid	Valid
	Other than the values above	Error	Error
Save manufacturer defined parameters	00000000h	Invalid	Invalid
	65766173h ("save")	Valid	Invalid
	Other than the values above	Error	Error
Save Point table	00000000h	Invalid	Invalid
	65766173h ("save")	Invalid	Valid
	Other than the values above	Error	Error

4. MODBUS REGISTERS

4.6 Alarm Information (Address: 1001h)

The error status can be checked.

4.6.1 List of registers

Address	Name	Data type	Read/write	No. of points/ No. of registers	Continuous read/ continuous write
1001h	Error Register	1 byte	Read	1	Impossible

4.6.2 Directions for use

The occurrence of an alarm can be read using the function code "03h" (Read Holding Registers). The following table shows the response data.

Response data	Status
00h	No alarms or warnings
01h	Alarms and warnings

When an alarm or a warning has occurred, alarm numbers, warning numbers, and detail numbers can be read from the register "2A41h".

4.7 Alarm Number (Address: 2A41h)

Alarm numbers, warning numbers, and detail numbers that currently exist can be read.

4.7.1 List of registers

Address	Name	Data type	Read/write	No. of points/ No. of registers	Continuous read/ continuous write
2A41h	Current alarm	4 bytes	Read	2	Impossible

4.7.2 Directions for use

Alarm numbers, warning numbers, and detail numbers that currently exist can be read using the function code "03h" (Read Holding Registers). An alarm number or warning number is stored in the higher bits of the response data, and a detail number is stored in the lower bits of the response data.

Address	Response data	When [AL 20.3] has occurred
Higher 2 bytes of 2A41h	Alarm number or warning number	0020h
Lower 2 bytes of 2A41h	Detail number	0003h

When data in this register is read while no error has occurred, "00000000h" is returned.

4. MODBUS REGISTERS

4.8 Alarm Occurrence Monitor (Address: 2B81h to 2BFFh)

Each monitor information at occurrence of an error can be read.

4.8.1 List of registers

Address	Name	Unit	Data type	Read/write	No. of points/ No. of registers	Continuous read/ continuous write
2B81h	Cumulative feedback pulses	pulse	4 bytes	Read	2	Possible
2B82h	Servo motor speed	r/min	4 bytes	Read	2	Possible
2B83h	Droop pulses	pulse	4 bytes	Read	2	Possible
2B84h	Cumulative command pulses	pulse	4 bytes	Read	2	Possible
2B85h	Command pulse frequency	kpulse/s	4 bytes	Read	2	Possible
2B86h	Analog speed command voltage Analog speed limit voltage	0.01 V	2 bytes	Read	1	Possible
2B87h	Analog torque limit voltage Analog torque command voltage	0.01 V	2 bytes	Read	1	Possible
2B88h	Regenerative load ratio	%	2 bytes	Read	1	Possible
2B89h	Effective load ratio	%	2 bytes	Read	1	Possible
2B8Ah	Peak load ratio	%	2 bytes	Read	1	Possible
2B8Bh	Instantaneous torque	%	2 bytes	Read	1	Possible
2B8Ch	Position within one-revolution	pulse	4 bytes	Read	2	Possible
2B8Dh	ABS counter	rev	4 bytes	Read	2	Possible
2B8Eh	Load to motor inertia ratio	0.01 times	2 bytes	Read	1	Possible
2B8Fh	Bus voltage	V	2 bytes	Read	1	Possible
2B90h to 2BA4h	Reserved					
2BA5h	Encoder inside temperature	°C	2 bytes	Read	1	Possible
2BA6h	Settling time	ms	2 bytes	Read	1	Possible
2BA7h	Oscillation detection frequency	Hz	2 bytes	Read	1	Possible
2BA8h	Number of tough operations	times	2 bytes	Read	1	Possible
2BA9h	Reserved					
2BAAh						
2BABh						
2BACh						
2BADh	Unit power consumption	W	2 bytes	Read	1	Possible
2BAEh	Unit total power consumption	Wh	4 bytes	Read	2	Possible
2BAFh	Current position	0.001 mm (Note 1)	4 bytes	Read	2	Possible
2BB0h	Command position	0.001 mm (Note 1)	4 bytes	Read	2	Possible
2BB1h	Remaining command distance	0.001 mm (Note 1)	4 bytes	Read	2	Possible
2BB2h	Point table No./Program No.		2 bytes	Read	1	Possible

4. MODBUS REGISTERS

Address	Name	Unit	Data type	Read/write	No. of points/ No. of registers	Continuous read/ continuous write
2BB3h	Step No.		2 bytes	Read	1	Possible
2BB4h	Override voltage	0.01 V	2 bytes	Read	1	Possible
2BB5h	Override level	%	2 bytes	Read	1	Possible
2BB6h	Reserved					
2BB7h						
2BB8h	Current position in one cycle of CAM axis	0.001 mm (Note 2)	4 bytes	Read	2	Possible
2BB9h	Basis position of CAM	0.001 mm (Note 1)	4 bytes	Read	2	Possible
2BBAh	Feed current position of CAM	0.001 mm (Note 1)	4 bytes	Read	2	Possible
2BBBh	CAM No.		2 bytes	Read	1	Possible
2BBCh	Stroke movement of CAM	0.001 mm (Note 1)	4 bytes	Read	2	Possible
2BBDh	Current position of main axis	0.001 mm (Note 2)	4 bytes	Read	2	Possible
2BBEh	Current position in one cycle of main axis	0.001 mm (Note 2)	4 bytes	Read	2	Possible
2BBFh to 2BFFh	Reserved					

Note 1. The unit and magnification change depending on the setting values of [Pr. PT01] and [Pr. PT03].

2. The unit and magnification change depending on the setting values of [Pr. PT01] and [Pr. PT03], or the setting of [Cam control data No. 14].

4.8.2 Directions for use

Set the address of the item to be monitored using the function code "03h" (Read Holding Registers). The value of the specified monitor item is returned from the servo amplifier.

Data in these registers can be continuously read. Data in continuous registers can be read at once. An error occurs if the register for manufacturer setting.

4. MODBUS REGISTERS

4.9 Alarm History (Address: 2A00h to 2A0Fh)

The history of up to 16 alarms can be read.

4.9.1 List of registers

Address	Name	Data type	Read/write	No. of points/ No. of registers	Continuous read/ continuous write	
2A00h to 2A0Fh	Alarm History0 to Alarm History15	Number of entries	1 byte	Read	5	Impossible
		Alarm No.	4 bytes			
		Alarm time (Hour)	4 bytes			

4.9.2 Directions for use

The history of alarms can be read using the function code "03h" (Read Holding Registers). At this time, "02h" is returned to Number of entries. The alarm number of a specified alarm history is returned to Alarm No. The alarm number or warning number is returned to the higher 2 bytes, and the detail number is returned to the lower 2 bytes. When no alarm history exists, "00000000h" is returned.

Alarm No.	Response data	When [AL 20.3] has occurred
Higher 2 bytes	Alarm number or warning number	0020h
Lower 2 bytes	Detail number	0003h

The alarm time (Unit: hour) of a specified alarm history is returned to Alarm time. When no alarm history exists, "00000000h" is returned.

4.10 Alarm History Clear (Address: 2A40h)

The alarm history can be cleared.

4.10.1 List of registers

Address	Name	Data type	Read/write	No. of points/ No. of registers	Continuous read/ continuous write
2A40h	Clear alarm history	2 bytes	Writing	1	Impossible

4.10.2 Directions for use

The history of alarms can be cleared by writing "1EA5h" using the function code "10h" (Preset Multiple Registers). When a value other than "1EA5h" is written, the history of alarms cannot be cleared.

4. MODBUS REGISTERS

4.11 Parameter Error Count (Address: 2A44h)

When [AL. 37 parameter error] has occurred, the number of parameters where parameter errors have occurred can be read.

4.11.1 List of registers

Address	Name	Data type	Read/write	No. of points/ No. of registers	Continuous read/ continuous write
2A44h	Parameter error No.	1 byte	Read	1	Impossible

4.11.2 Directions for use

Read the parameter error number count using the function code "03h" (Read Holding Registers). When no parameter error has occurred, "00h" is returned.

4.12 Parameter Error List (Address: 2A45h)

The error numbers of the currently existing parameter errors can be read.

4.12.1 List of registers

Address	Name	Data type	Read/write	No. of points/ No. of registers	Continuous read/ continuous write
2A45h	Parameter error list	Number of entries	Read	1 + Number of read points	Impossible
		Parameter error 1 to Parameter error 32			

4.12.2 Directions for use

Read the parameter error numbers using the function code "03h" (Read Holding Registers). At this time, set the value read with the parameter error count (2A44h) for Number of entries. Note that up to 32 parameter errors can be read.

Parameter error 1 to Parameter error 32 store parameter error numbers. Parameter group numbers are stored in the higher 8 bits, and parameter numbers are stored in the lower 8 bits. The following table lists parameter group numbers.

Parameter group	Number
Basic setting parameters [Pr. PA_ _]	00
Gain/filter setting parameters [Pr. PB_ _]	01
Extension setting parameters [Pr. PC_ _]	02
I/O setting parameters [Pr. PD_ _]	03
Extension setting 2 parameters [Pr. PE_ _]	04
Extension setting 3 parameters [Pr. PF_ _]	05
Positioning control parameters [Pr. PT_ _]	0C

4. MODBUS REGISTERS

4.13 Point Table Error (Address: 2A43h)

When a point table error [AL. 37] has occurred, the detail of the point table where the point table error has occurred can be read.

4.13.1 List of registers

Address	Name		Data type	Read/write	No. of points/ No. of registers	Continuous read/ continuous write
2A43h	Point Table error No.	Number of entries	1 byte	Read	4	Impossible
		Point Table Error No.	2 bytes			
		Point Table Error Factor	4 bytes			

4.13.2 Directions for use

Read a point table error number using the function code "03h" (Read Holding Registers). At this time, "02h" is returned to Number of entries.

The factor of the error that has occurred in the point table with the number read with Point Table Error No. is stored in Point Table Error Factor.

The following table describes the assignment of bits for point table error factors. The values in the areas marked with diagonal lines are indefinite.

Bit	Error factor bit details
0	0: No error 1: Target position
1	/
2	0: No error 1: Servo motor speed
3	0: No error 1: Acceleration time constant
4	0: No error 1: Deceleration time constant
5	0: No error 1: Dwell
6	0: No error 1: Sub function
7	0: No error 1: M code (Note)
8 to 31	/

Note. M code will be available in the future.

4. MODBUS REGISTERS

4.14 External Input Pin Status (Address: 2C10h)

The ON/OFF state of the external input pins input to the servo amplifier can be read.

4.14.1 List of registers

Address	Name	Data type	Read/write	No. of points/ No. of registers	Continuous read/ continuous write
2C10h	External Input pin display	Number of entries	1 byte	Read	3
		External Input pin display1	4 bytes		

4.14.2 Directions for use

Read the ON/OFF state of external input pins using the function code "03h" (Read Holding Registers). At this time, "02h" is returned to Number of entries.

External Input pin display1 displays the input pin status of the MR-JE-_A servo amplifier. The following table shows the details. When the input of the target pin is on, "1" is returned. When the input of the target pin is off, "0" is returned. The values in the areas marked with diagonal lines are indefinite.

Bit	CN1 connector pin	Bit	CN1 connector pin	Bit	CN1 connector pin	Bit	CN1 connector pin
0	43	8		16		24	
1	44	9		17		25	
2	42	10		18		26	
3	15	11		19		27	
4	19	12		20		28	
5	41	13		21		29	
6	10	14		22		30	
7	35	15		23		31	

4. MODBUS REGISTERS

4.15 External Output Pin Status (Address: 2C11h)

The ON/OFF state of external output pins output from the servo amplifier can be read.

4.15.1 List of registers

Address	Name		Data type	Read/write	No. of points/ No. of registers	Continuous read/ continuous write
2C11h	External Output pin display	Number of entries	1 byte	Read	3	Impossible
		External Output pin display1	4 bytes			

4.15.2 Directions for use

Read the ON/OFF state of external output pins using the function code "03h" (Read Holding Registers). At this time, "02h" is returned to Number of entries.

External Output pin display1 displays the output pin status of the MR-JE-_A servo amplifier. The following table shows the details. When the output of the target pin is on, "1" is returned. When the output of the target pin is off, "0" is returned. The values in the areas marked with diagonal lines are indefinite.

Bit	CN1 connector pin	Bit	CN1 connector pin	Bit	CN1 connector pin	Bit	CN1 connector pin
0	49	8		16		24	
1	24	9		17		25	
2	23	10		18		26	
3		11		19		27	
4		12		20		28	
5	48	13		21		29	
6	33	14		22		30	
7		15		23		31	

4.16 Input Device Status (Address: 2C12h)

The current input device status can be read.

4.16.1 List of registers

Address	Name		Data type	Read/write	No. of points/ No. of registers	Continuous read/ continuous write
2C12h	External Input signal display	Number of entries	1 byte	Read	9	Impossible
		External Input signal display1	4 bytes			
		External Input signal display2	4 bytes			
		External Input signal display3	4 bytes			
		External Input signal display4	4 bytes			

4. MODBUS REGISTERS

4.16.2 Directions for use

Read the ON/OFF state of input devices using the function code "03h" (Read Holding Registers). At this time, "04h" is returned to Number of entries.

External Input signal display1 (Input device status 1) to External Input signal display4 (Input device status 4) display the ON/OFF state of each input device of the MR-JE-_A servo amplifier. The following table shows the details. When the input of the target device is on, "1" is returned. When the input of the target device is off, "0" is returned. The values in the areas marked with diagonal lines are indefinite.

Bit	Input device abbreviation (Note 1)		
	Input device status 1	Input device status 2	Input device status 3
0	SON		MD0
1	LSP		
2	LSN		
3	TL		TCH
4	TL1		TP0
5	PC		TP1
6	RES		OVR
7	CR		
8	SP1		
9	SP2		DOG
10	SP3		
11	ST1/RS2		
12	ST2/RS1		
13	CMX1		
14	CMX2		
15	LOP		
16		MSD	LPS
17		PI1	
18	EM2/EM1	PI2	
19		PI3	
20	STAB2	CAMC	
21		CI0	
22		CI1	
23		CI2	
24	TSTP	CI3	DI0
25		CLTC (Note 2)	DI1
26		CPCD (Note 2)	DI2
27	CDP		DI3
28			DI4
29			
30			
31			

Note 1. Refer to "MELSERVO-JE-_A Servo Amplifier Instruction Manual" and "MELSERVO-JE-_A Servo Amplifier Instruction Manual (Positioning Mode)" for the details on the abbreviation.

2. This is available with servo amplifiers with software version C1 or later.

4. MODBUS REGISTERS

4.17 Output Device Status (Address: 2C13h)

The current output device status can be read.

4.17.1 List of registers

Address	Name	Data type	Read/write	No. of points/ No. of registers	Continuous read/ continuous write	
2C13h	External Output signal display	Number of entries	1 byte	Read	9	Impossible
		External Output signal display1	4 bytes			
		External Output signal display2	4 bytes			
		External Output signal display3	4 bytes			
		External Output signal display4	4 bytes			

4. MODBUS REGISTERS

4.17.2 Directions for use

Read the ON/OFF state of output devices using the function code "03h" (Read Holding Registers). At this time, "04h" is returned to Number of entries.

External Output signal display1 (Output device status 1) to External Output signal display4 (Output device status 4) display the ON/OFF state of each output device of the MR-JE-_A servo amplifier. The following table shows the details. When the output of the target device is on, "1" is returned. When the output of the target device is off, "0" is returned. The values in the areas marked with diagonal lines are indefinite.

Bit	Output device abbreviation (Note 1)		
	Output device status 1	Output device status 2	Output device status 3
0	RD		
1	SA		
2	ZSP		
3	TLC		CPO
4	VLC		ZP
5	INP		POT
6			PUS
7	WNG		MEND
8	ALM		
9	OP		
10	MBR		
11	DB		
12	ALCD0		PED
13	ALCD1		
14	ALCD2		
15			
16			
17			ALMWNG
18			
19		MSDH	
20		MSDL	
21		SOUT	
22		OUT1	
23		OUT2	
24		OUT3	PT0
25	CDPS	CAMS	PT1
26		CLTS (Note 2)	PT2
27		CLTSM (Note 2)	PT3
28		CPCC (Note 2)	PT4
29			
30			
31	MTR		

Note 1. Refer to "MELSERVO-JE-_A Servo Amplifier Instruction Manual" and "MELSERVO-JE-_A Servo Amplifier Instruction Manual (Positioning Mode)" for the details on the abbreviation.

2. This is available with servo amplifiers with software version C1 or later.

4. MODBUS REGISTERS

4.18 Servo Amplifier Model (Address: 1008h)

The model name of the currently-connected servo amplifier can be read.

4.18.1 List of registers

Address	Name	Data type	Read/write	No. of points/ No. of registers	Continuous read/ continuous write
1008h	Manufacture Device Name	32 bytes	Read	16	Impossible

4.18.2 Directions for use

Read the model name of the servo amplifier using the function code "03h" (Read Holding Registers). The model name of the servo amplifier is returned in ASCII codes. The ASCII codes are read in order from the lower address.

4.19 Servo Amplifier Software Version (Address: 100Ah)

The software version of the currently-connected servo amplifier can be read.

4.19.1 List of registers

Address	Name	Data type	Read/write	No. of points/ No. of registers	Continuous read/ continuous write
100Ah	Manufacture Software Version	16 bytes	Read	8	Impossible

4.19.2 Directions for use

Read the software version of the servo amplifier using the function code "03h" (Read Holding Registers). The software version of the servo amplifier is returned in ASCII codes. The ASCII codes are read in order from the lower address.

4. MODBUS REGISTERS

4.20 Broadcast Setting (Address: 2D98h)

The setting of the broadcast communication of the Modbus RTU communication can be configured. The broadcast command can be disabled for each axis using this register.

4.20.1 List of registers

Address	Name	Data type	Read/write	No. of points/ No. of registers	Continuous read/ continuous write
2D98h	Select behavior of broadcast message	1 byte	Read/write	1	Impossible

4.20.2 Directions for use

The current broadcast communication setting can be read using the function code "03h" (Read Holding Registers).

Configure the broadcast communication setting using the function code "10h" (Preset Multiple Registers).

The following table lists the setting values for this register. Do not set any value other than "00h" and "01h".

Setting value	Description
0	Broadcast instruction enabled
1	Broadcast instruction disabled

4.21 Servo Motor Rated Speed (Address: 2D28h)

The servo motor rated speed ([r/min]) can be read.

4.21.1 List of registers

Address	Name	Data type	Read/write	No. of points/ No. of registers	Continuous read/ continuous write
2D28h	Motor rated speed	4 bytes	Read	2	Impossible

4.21.2 Directions for use

Read the servo motor rated speed ([r/min]) using the function code "03h" (Read Holding Registers).

4.22 Servo Motor Maximum Speed (Address: 2D29h)

The servo motor maximum speed ([r/min]) can be read.

4.22.1 List of registers

Address	Name	Data type	Read/write	No. of points/ No. of registers	Continuous read/ continuous write
2D29h	Motor max speed	4 bytes	Read	2	Impossible

4.22.2 Directions for use

Read the servo motor maximum speed ([r/min]) using the function code "03h" (Read Holding Registers).

4. MODBUS REGISTERS

4.23 SDO Abort Code (Address: 2A60h)

The latest SDO Abort Code can be read.

The access to registers can be checked by reading the latest SDO Abort Code.

When an error is found by reading SDO Abort Codes, change the method to access registers.

4.23.1 List of registers

Address	Name	Data type	Read/write	No. of points/ No. of registers	Continuous read/ continuous write
2A60h	SDO Abort Code	4 bytes	Read	2	Impossible

4.23.2 Directions for use

Read SDO Abort Codes using the function code "03h" (Read Holding Registers).

The following table lists the SDO Abort Codes.

SDO Abort Code	Description
0000 0000h	No error
0504 0001h	Client/server command specifier not valid or unknown.
0601 0000h	Unsupported access to an object.
0601 0001h	Attempt to read a write only object.
0601 0002h	Attempt to write a read only object.
0602 0000h	Object does not exist in the object dictionary.
0607 0010h	Data type does not match, length of service parameter does not match.
0609 0011h	Sub-index does not exist.
0609 0030h	Value range of parameter exceeded (only for write access).
0609 0031h	Value of parameter written too high.
0609 0032h	Value of parameter written too low.
0800 0000h	Generic error.
0800 0021h	Data cannot be transferred or stored to the application because of local control.
0800 0022h	Data cannot be transferred or stored to the application because of the present device state.
0800 0024h	No data available.

4.24 Access Log 1 (Address: 2A64h)

The access log 1 can be read.

4.24.1 List of registers

Address	Name	Data type	Read/write	No. of points/ No. of registers	Continuous read/ continuous write
2A64h	Access log 1	4 bytes	Read	2	Impossible

4.24.2 Directions for use

Read the access log 1 using the function code "03h" (Read Holding Registers).

The access log 1 displays the Index and SubIndex that were lastly accessed using the Modbus RTU communication.

Access log 1	Response data
Higher 2 bytes	Index: xxxxh
Lower 2 bytes	SubIndex: 00yyh

For example, when the access to a point table (address: 2801h) succeeded, the read value of the access log 1 is "28010007h".

4. MODBUS REGISTERS

4.25 Access Log 2 (Address: 2A65h)

The access log 2 can be read.

4.25.1 List of registers

Address	Name	Data type	Read/write	No. of points/ No. of registers	Continuous read/ continuous write
2A65h	Access log 2	2 bytes	Read	1	Impossible

4.25.2 Directions for use

Read the access log 2 using the function code "03h" (Read Holding Registers).

The access log 2 displays the number of addresses that were lastly accessed using the Modbus RTU communication.

Use this register when an access error has occurred in the continuous read/write.

For example, when an error has occurred while the registers for monitoring (address: 2B01h to 2B0Ah) are continuously read, the error has occurred at the address 2B07h because the read value of the access log 2 is "0006h".

4.26 Communication Error Count (Address: 2A68h)

The Modbus RTU communication error count can be read.

4.26.1 List of registers

Address	Name	Data type	Read/write	No. of points/ No. of registers	Continuous read/ continuous write
2A68h	Communication error count	2 bytes	Read	1	Impossible

4.26.2 Directions for use

The total count of the following communication errors can be read using the function code "03h" (Read Holding Registers).

- Errors detected by hardware (parity error, overrun error, and framing error)
- Message frame length error
- CRC error

Executing Clear alarm history clears the error count. For details of Clear alarm history, refer to section 4.10.

4. MODBUS REGISTERS

4.27 Supported Profile Information (Address: 1000h)

The supported profile information can be read.

4.27.1 List of registers

Address	Name	Data type	Read/write	No. of points/ No. of registers	Continuous read/ continuous write
1000h	Device type	4 bytes	Read	2	Impossible

4.27.2 Directions for use

Read the supported profile information using the function code "03h" (Read Holding Registers). The following table shows the response data.

Device type	Response data
Higher 2 bytes	0002h (Servo drive)
Lower 2 bytes	0192h (CiA 402)

4.28 Device Information (Address: 1018h)

The device information can be read.

4.28.1 List of registers

Address	Name	Data type	Read/write	No. of points/ No. of registers	Continuous read/ continuous write	
1018h	Device type	Number of entries	1 byte	Read	9	Impossible
		Vendor ID	4 bytes			
		Product code	4 bytes			
		Revision number	4 bytes			
		Serial number	4 bytes			

4.28.2 Directions for use

Read the device information using the function code "03h" (Read Holding Registers). The following table shows the response data.

Item	Response data
Number of entries	04h
Vendor ID	00000A1Eh
Product code	00000203h
Revision number	00010000h
Serial number	00000000h

5. DRIVING MOTOR

5. DRIVING MOTOR

POINT
<ul style="list-style-type: none"> ● Use a servo motor after setting [Pr. PF46 Modbus RTU communication time out selection]. The servo motor may continue to operate after the communication is disabled due to a communication shut-off or other causes.

This chapter describes how to drive a servo motor in the Modbus RTU communication. For MR-JE-_A servo amplifier, Modbus registers are assigned like the address assignment of CiA 402 drive profile. The servo motors are driven by Modbus compatible controller as master accessing to the assigned holding registers. The following shows a list of functions that can be used.

Function	Description	Detailed explanation
Device control	The master (controller) can control the state machine of the slave (servo amplifier) to drive the servo motor.	Section 5.1
Control mode	The following modes can be selected: each control mode, home position return mode, JOG operation mode, point table mode, and program drive mode.	Section 5.2
Home position return mode	In this mode, the servo amplifier performs a home position return operation using the method directed by the master (controller).	Section 5.3
JOG operation mode	In this mode, the servo motor is manually driven at a speed set by the master (controller).	Section 5.4
Point table operation mode	In this mode, the servo motor is driven with a prespecified point table.	Section 5.5
Program drive mode	In this mode, the servo motor is driven with a prespecified program.	Section 5.6
Touch probe	The current position latch data at the rising edge and falling edge of sensor inputs can be read.	Section 5.7
Function common to the modes	This function uses the common registers that can be used for the home position return mode, JOG operation mode, point table operation mode, and program operation mode.	Section 5.8

5. DRIVING MOTOR

5.1 Device Control

5.1.1 Function description

The servo amplifier status is managed based on the state machine below. Setting the control command (6040h) from the master (controller) changes the status of the slave (servo amplifier). The current servo amplifier status can be read with the control status (6041h).

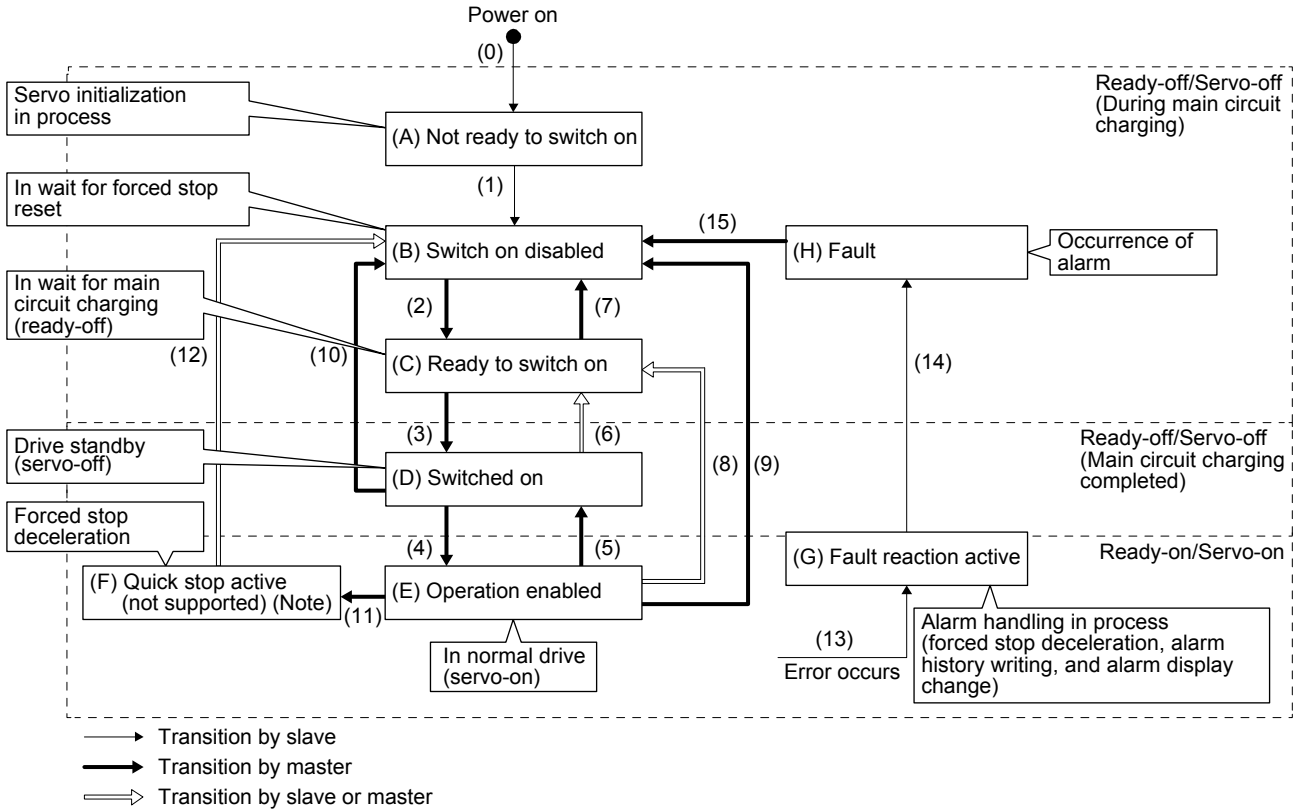

Note. This is not supported by the MR-JE-_A servo amplifier.

5. DRIVING MOTOR

5.1.2 Related registers

Address	Name	Data type	Read/write	No. of points/ No. of registers	Continuous read/ continuous write
6040h	Controlword	2 bytes	Read/write	1	Impossible
6041h	Statusword	2 bytes	Read	1	Impossible

5.1.3 Details of registers

(1) Control command (Controlword: 6040h)

This register issues a command from the master (controller) to the slave (servo amplifier).

Address	Name	Data type	Read/write	No. of points/ No. of registers	Continuous read/ continuous write
6040h	Controlword	2 bytes	Read/write	1	Impossible

The current control command status can be checked using the function code "03h" (Read Holding Registers).

A control command can be written using the function code "10h" (Preset Multiple Registers).

The following table lists the bits of this register. The slave can be controlled with bit 0 to bit 3 and bit 7.

Bit	Description
0	Switch On
1	Enable Voltage
2	Quick Stop
3	Enable Operation
4 to 6	Operation Mode Specific (Note 1)
7	Fault Reset
8	Halt
9 to 15	Reserved (Note 2)

Note 1. The description changes depending on the control mode.

Note 2. The value at reading is undefined. Set "0" at writing.

The following table lists the commands issued to the servo amplifier. Turn on the bit that corresponds to the command.

Command	Bit 7	Bit 3	Bit 2	Bit 1	Bit 0
Shutdown	0		1	1	0
Switch On	0	0	1	1	1
Disable voltage	0			0	
Quick stop (not supported) (Note)	0		0	1	
Disable operation	0	0	1	1	1
Enable operation	0	1	1	1	1
Fault reset	0 → 1				

Note. This is not supported by the MR-JE- A servo amplifier.

5. DRIVING MOTOR

(2) Control status (Statusword: 6041h)

Address	Name	Data type	Read/write	No. of points/ No. of registers	Continuous read/ continuous write
6041h	Statusword	2 bytes	Read	1	Impossible

The current control status can be checked using the function code "03h" (Read Holding Registers).
The following table lists the bits of this register. The status can be checked with bit 0 to bit 7.

Bit	Description
0	Ready To Switch On
1	Switched On
2	Operation Enabled
3	Fault
4	Voltage Enabled
5	Quick Stop
6	Switch On Disabled
7	Warning
8	Reserved (Note 2)
9	Remote
10	Target reached
11	Internal Limit Active
12 to 13	Operation Mode Specific (Note 1)
14 to 15	Reserved (Note 2)

Note 1. The description changes depending on the control mode.
2. The value at reading is undefined.

The following table lists the servo amplifier statuses that can be read with bit 0 to bit 7.

Bit 7	Bit 6	Bit 5	Bit 4	Bit 3	Bit 2	Bit 1	Bit 0	Status
	0			0	0	0	0	Not ready to switch on
	1			0	0	0	0	Switch on disable
	0	1		0	0	0	1	Ready to switch on
	0	1		0	0	1	1	Switch on
	0	1		0	1	1	1	Operation enabled
	0	0		0	1	1	1	Quick stop active (not supported) (Note)
	0			1	1	1	1	Fault reaction active
	0			1	0	0	0	Fault
			1					Main power on
1								Warning

Note. This is not supported by the MR-JE_A servo amplifier.

Bit 9 turns on when the control command (Controlword) is enabled in the Modbus RTU communication.
Bit 11 turns on when the stroke limit, software limit, or positioning command is outside the range.

5.1.4 Directions for use

The function code "10h" (Preset Multiple Registers) allows a transition to the target status, skipping the statuses in between.

The statuses can transition as shown in the following table, for example. (Refer to the figure in section 5.1.1.)

Current status	Command	Status after transition
(B) Switch on disabled	Switch on	(D) Switched on
(B) Switch on disabled	Enable operation	(E) Operation enabled
(C) Ready to switch on	Enable operation	(E) Operation enabled

5. DRIVING MOTOR

5.2 Control Mode

This section describes the control modes that the MR-JE-_A servo amplifier supports.

5.2.1 Function description

The MR-JE-_A servo amplifier supports various control modes.

A control mode can be selected with the control mode (Modes of operation: 6060h).

The following table shows the correspondence between the control modes before and after switching.

		Control mode after switching						
		Position	Speed	Torque	Point table	Program	Home position return	JOG operation
Control mode before switching	Position		○	○	×	×	×	×
	Speed	○		○	×	×	×	×
	Torque	○	○		×	×	×	×
	Point table	×	×	×		×	○	○
	Program	×	×	×	×		○	○
	Home position return	×	×	×	○ (Note)	○ (Note)		○
	JOG operation	×	×	×	○ (Note)	○ (Note)	○	

○: Switchable ×: Non-switchable

Note. Use [Pr. PA01] to switch the mode between the point table and program.

After switching control modes, check that the control modes have been switched by monitoring the control mode display (Modes of operation Display: 6061h).

Switch control modes while the servo motor is being stopped.

5.2.2 Related registers

Address	Name	Data type	Read/write	No. of points/ No. of registers	Continuous read/ continuous write
6060h	Modes of operation	1 byte	Read/write	1	Impossible
6061h	Modes of operation Display	1 byte	Read	1	Impossible
6502h	Supported Drive Modes	4 bytes	Read	2	Impossible

5.2.3 Details of registers

(1) Control mode (Modes of operation: 6060h)

Address	Name	Data type	Read/write	No. of points/ No. of registers	Continuous read/ continuous write
6060h	Modes of operation	1 byte	Read/write	1	Impossible

The current control mode setting can be checked using the function code "03h" (Read Holding Registers).

Control modes can be switched by setting a control mode using the function code "10h" (Preset Multiple Registers).

The following table shows the correspondence between control modes and setting values.

Control mode	Setting value
Position control	-20
Speed control	-21
Torque control	-22
Point table	-101
Program operation	-102
Home position return	6
JOG operation	-100

5. DRIVING MOTOR

(2) Control mode display (Modes of operation Display: 6061h)

Address	Name	Data type	Read/write	No. of points/ No. of registers	Continuous read/ continuous write
6061h	Modes of operation Display	1 byte	Read	1	Impossible

The current control mode can be read using the function code "03h" (Read Holding Registers).

The following table shows the correspondence between control modes and setting values.

Control mode	Setting value
Position control	-20
Speed control	-21
Torque control	-22
Point table	-101
Program operation	-102
Home position return	6
JOG operation	-100
Test mode: JOG operation	-1
Test mode: Positioning operation	-2
Test mode: DO forced output	-4
Test mode: Machine analyzer	-6
Test mode: One-step feed (in point table operation)	-10
Test mode: One-step feed (in program operation)	-11

(3) Supported control mode (Supported Drive Modes: 6502h)

Address	Name	Data type	Read/write	No. of points/ No. of registers	Continuous read/ continuous write
6502h	Supported Drive Modes	4 bytes	Read	2	Impossible

Supported control modes can be read using the function code "03h" (Read Holding Registers).

The return value is 00070020h. The following table shows the details.

Bit	Supported Modes	Defined value
0	Profile Position mode	0
1	Velocity mode	0
2	Profile Velocity mode	0
3	Torque Profile mode	0
4	Reserved	0
5	Homing Mode	1: Supported
6	Interpolated Position mode	0
7	Cyclic Sync Position mode	0
8	Cyclic Sync Velocity mode	0
9	Cyclic Sync Torque mode	0
10 to 15	Reserved	0
16	JOG mode	1: Supported
17	Point table mode	1: Supported
18	Program drive mode	1: Supported
19 to 31	Reserved	0

5. DRIVING MOTOR

5.2.4 Directions for use

- (1) Positioning with point table operation ([Pr. PA01]: "_ _ _ 6")
After performing a home position return operation, perform a point table operation. Use the control mode (Modes of operation: 6060h) when switching the mode to the home position return or point table operation.
- (2) Registering the destination position data by a JOG operation ([Pr. PA01]: "_ _ _ 6") as the position data in a point table
After performing a home position return operation, perform a JOG operation to reach the target position and register the position data to a point table. Use the control mode (Modes of operation: 6060h) when switching the mode to the home position return or JOG operation.
- (3) Performing speed control ([Pr. PA01]: "_ _ _ 1") when [Pr. PC71] is "21_1"
Use the control mode (Modes of operation: 6060h) to switch the mode to the speed control, torque control, or position control.

5.3 Home Position Return Mode

This section describes how to perform a home position return operation in the Modbus RTU communication.

5.3.1 Function description

Perform a home position return operation following the instruction below.

After setting the home position return method (Homing method: 6098h), home position return speed (Homing speed: 6099h), and home position return acceleration/deceleration time constant, start the operation with the control command (Controlword: 6040h). The specified home position return operation is performed. The completion of the home position return operation can be checked with the control status (Statusword: 6041h).

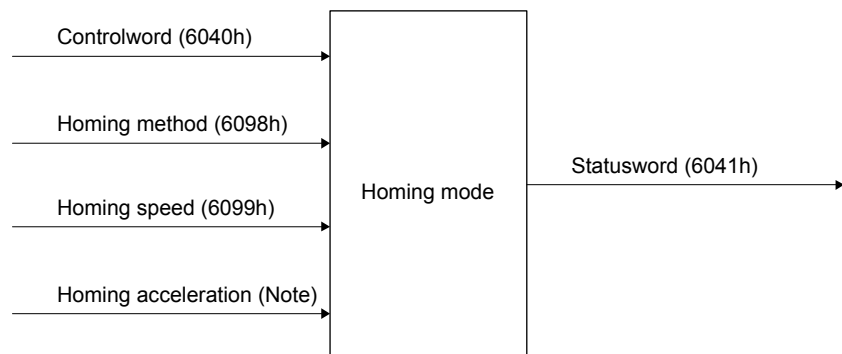

Note. In the point table mode, use the acceleration time constant and deceleration time constant in point table No. 1 (2801h).

In the program drive mode, Use [Pr. PC30] (211Eh) and [Pr. PC31] (211Fh).

5. DRIVING MOTOR

5.3.2 Related registers

Address	Name	Data type	Read/write	No. of points/ No. of registers	Continuous read/ continuous write	
6040h	Controlword	2 bytes	Read/write	1	Impossible	
6098h	Homing method	1 byte	Read/write	1	Impossible	
6099h	Homing speed	Number of entries	1 byte	Read/write	5	Impossible
		Speed during search for switch	4 bytes			
		Speed during search for zero	4 bytes			
6041h	Statusword	2 bytes	Read	1	Impossible	

For details of the change to the acceleration time constant or deceleration time constant in point table No. 1 used for a home position return operation in the point table mode, refer to Section 4.4.

For details of the change to the acceleration time constant parameter [Pr. PC30] and deceleration time constant parameter [Pr. PC31] used for a home position return operation in the program mode, refer to Section 4.3.

5.3.3 Details of registers

(1) Control command (Controlword: 6040h)

Address	Name	Data type	Read/write	No. of points/ No. of registers	Continuous read/ continuous write
6040h	Controlword	2 bytes	Read/write	1	Impossible

The status of the current control command input can be checked using the function code "03h" (Read Holding Registers).

A control command can be written using the function code "10h" (Preset Multiple Registers).

The bits of this register that relate to the home position return operation are shown below.

Bit	Description
0 to 3	Refer to section 5.1.3.
4	Homing Operation Start
5 to 6	Reserved (Note)
7	Refer to section 5.1.3.
8	Halt
9 to 15	Refer to section 5.1.3.

Note. The value at reading is undefined. Set "0" at writing.

To start a home position return operation, turn bit 4 from "0" to "1". When the home position return operation is completed or an alarm is issued during the operation, turn bit 4 from "1" to "0".

When bit 8 (Halt) of the control command (6040h) is set to "1", the servo motor decelerates to a stop.

Then, when bit 8 (Halt) is set to "0" and bit 4 is turned from "0" to "1", the home position return operation resumes.

5. DRIVING MOTOR

(2) Home position return method (Homing method: 6098h)

Address	Name	Data type	Read/write	No. of points/ No. of registers	Continuous read/ continuous write
6098h	Homing method	1 byte	Read/write	1	Impossible

The current home position return method can be read using the function code "03h" (Read Holding Registers).

Set a home position return method using the function code "10h" (Preset Multiple Registers). To enable the written home position return method after turning the power back on, execute the writing command to EEPROM (1010h). After the execution of the writing command to EEPROM, the values of [Pr. PT04] and [Pr. PT45] are changed.

The following table lists selectable home position return methods.

Setting value	Home position return method	Direction of rotation	Description	Home position return parameter	
				[Pr. PT04] (_ _ x x)	[Pr. PT45] (_ _ x x)
Other than the values below	Home position return method selected with [Pr. PT04] or [Pr. PT45]	-	The home position return method specified with [Pr. PT04] or [Pr. PT45] is used.	Value being set	Value being set
7	Homing on home switch and index pulse	Forward	When the front end of the proximity dog is detected, the travel in the reverse direction starts. Then, the position where the first Z-phase signal is detected is set as a home position.	(Note)	07h
11		Reverse		(Note)	0Bh
8		Forward	The position specified by the first Z-phase signal after the front end of the proximity dog is detected is set as a home position.	(Note)	08h
12		Reverse		(Note)	0Ch
23	Homing without index pulse	Forward	After the front end of the proximity dog is detected, the position is shifted in the reverse direction and the position on the front end (edge) of the proximity dog is set as a home position.	(Note)	17h
27		Reverse		(Note)	1Bh
35	Homing on current position	-	The current position is set as the home position.	(Note)	23h
37		-		(Note)	25h
-1	Dog type (Rear-end detection Z-phase reference)	Forward	At the front end of the proximity dog, deceleration starts. After the rear end is passed, the position specified by the first Z-phase signal or the position of the Z-phase signal shifted by the set home position shift distance is set as a home position.	00h	00h
-33		Reverse		10h	00h
-4	Stopper type (Stopper position reference)	Forward	The object is pressed against a mechanical stopper and the position where it is stopped is set as a home position.	03h	00h
-36		Reverse		13h	00h
-5	Home position ignorance (Servo-on position as home position)	-	The current position at servo-on is set as a home position. A home position can be set without switching to the home position return mode (Homing Mode).	04h	00h
-2	Count type (Front-end detection Z-phase reference)	Forward	At the front end of the proximity dog, deceleration starts. After the front end is passed, the position specified by the first Z-phase signal after the set distance or the position of the Z-phase signal shifted by the set home position shift distance is set as a home position.	01h	00h
-34		Reverse		11h	00h
-6	Dog type (Rear-end detection rear-end reference)	Forward	At the front end of the proximity dog, deceleration starts. After the rear end is passed, the position is shifted by the travel distance after the proximity dog and home position shift distance. The position after the shifts is set as a home position.	05h	00h
-38		Reverse		15h	00h

5. DRIVING MOTOR

Setting value	Home position return method	Direction of rotation	Description	Home position return parameter	
				[Pr. PT04] (_ x x)	[Pr. PT45] (_ x x)
-7	Count type (Front-end detection front-end reference)	Forward	At the front end of the proximity dog, deceleration starts. The position is shifted by the travel distance after the proximity dog and home position shift distance. The position after the shifts is set as a home position.	06h	00h
-39		Reverse		16h	00h
-8	Dog cradle type	Forward	The position specified by the first Z-phase signal after the front end of the proximity dog is detected is set as a home position.	07h	00h
-40		Reverse		17h	00h
-9	Dog type last Z-phase reference	Forward	When the front end of the proximity dog is detected, the travel in the reverse direction starts. Then, the position where the first Z-phase signal is detected is set as a home position or the position after a shift by the home position shift distance from the position specified by the first Z-phase signal is set as a home position.	08h	00h
-41		Reverse		18h	00h
-10	Dog type front end reference	Forward	From the front end of the proximity dog, the position is shifted by the travel distance after proximity dog and home position shift distance. The position after the shifts is set as a home position.	09h	00h
-42		Reverse		19h	00h
-11	Dogless Z-phase reference	Forward	The position specified by the first Z-phase signal or position of the first Z-phase signal shifted by the home position shift distance is set as a home position.	0Ah	00h
-43		Reverse		1Ah	00h

Note. Regardless of the [Pr. PT04] setting, the home position return type is determined only by the [Pr. PT45] setting.

(3) Home position return speed (Homing speed: 6099h)

Address	Name		Data type	Read/write	No. of points/ No. of registers	Continuous read/ continuous write
6099h	Homing speed	Number of entries	1 byte	Read/write	5	Impossible
		Speed during search for switch	4 bytes			
		Speed during search for zero	4 bytes			

The current home position return speed can be read using the function code "03h" (Read Holding Registers). At this time, "02h" is returned to Number of entries.

The current home position return speed is returned to Speed during search for switch in units of r/min.

The current creep speed is returned to Speed during search for zero in units of r/min.

Set a home position return speed using the function code "10h" (Preset Multiple Registers). At this time, write "02h" in Number of entries.

Set a home position return speed in Speed during search for switch in units of r/min.

Set a creep speed in Speed during search for zero in units of r/min.

5. DRIVING MOTOR

(4) Control status (Statusword: 6041h)

Address	Name	Data type	Read/write	No. of points/ No. of registers	Continuous read/ continuous write
6041h	Statusword	2 bytes	Read	1	Impossible

The current control status can be checked using the function code "03h" (Read Holding Registers). The bits of this register that relate to the home position return operation are shown below.

Bit	Description
0 to 9	Refer to section 5.1.3.
10	Target reached
11	Refer to section 5.1.3.
12	Homing attained
13	Homing error
14 to 15	Refer to section 5.1.3.

(a) Bit 10 of the control status (6041h) (Target reached)

Bit 10 turns on (1) when the command position is reached. If bit 8 (Halt) of the control command is set to "1", bit 10 turns on (1) when a deceleration stop is completed.

If a command is input again, bit 10 turns off (0).

(b) Bit 12 of the control status (6041h) (Homing attained)

Bit 12 turns off (0) when a home position return operation is started and turns on (1) when the operation is completed.

(c) Bit 13 of the control status (6041h) (Homing error)

Bit 13 turns on (1) when an alarm or warning ([AL 90.2], [AL 90.3], [AL 90.5], [AL 96.1], [AL 96.2], or [AL 96.3]) occurs during a home position return operation.

5. DRIVING MOTOR

5.3.4 Directions for use

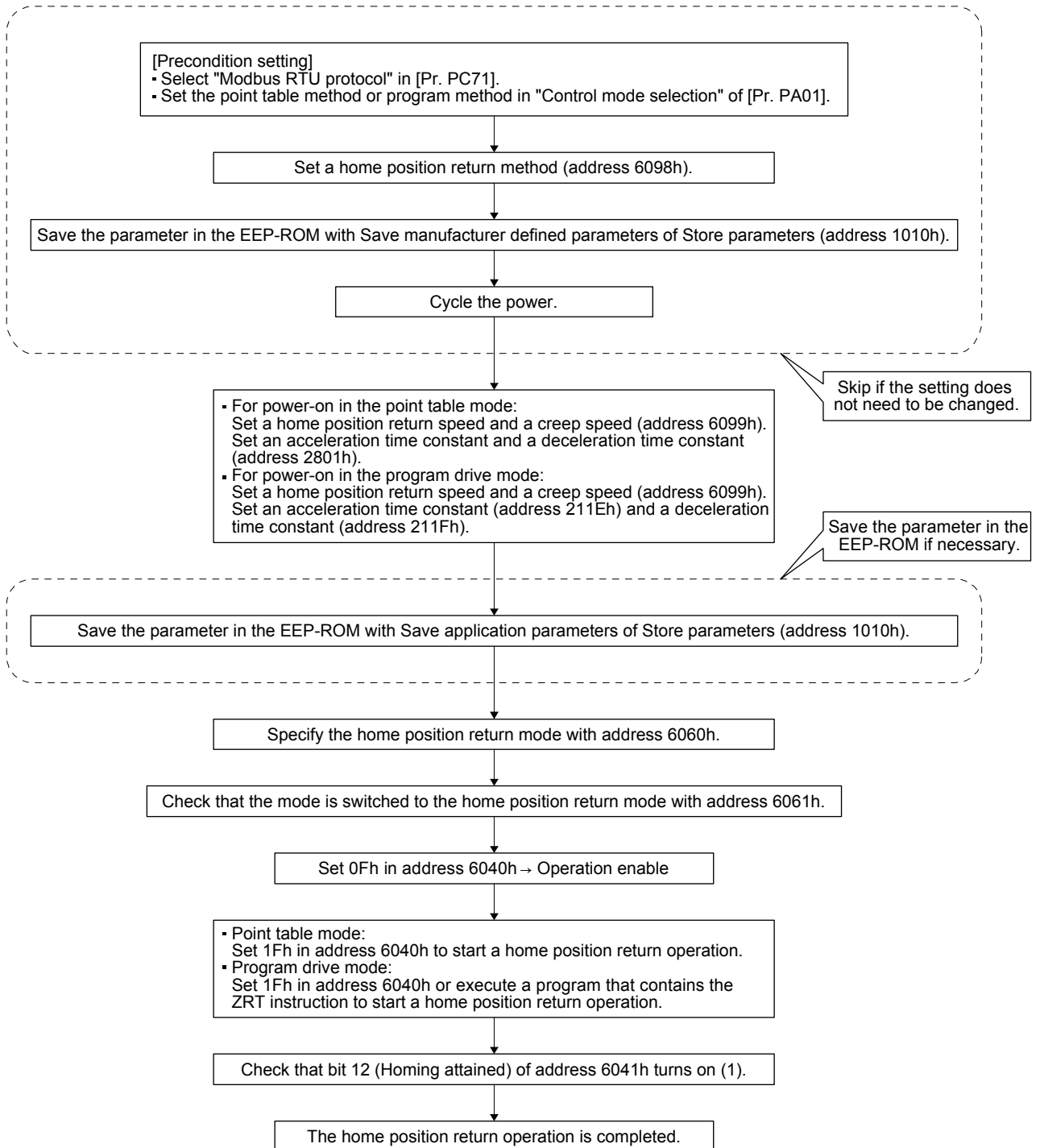

5. DRIVING MOTOR

5.4 JOG Operation Mode

This section describes how to perform a JOG operation in the Modbus RTU communication.

5.4.1 Function description

Perform a JOG operation following the instruction below.

After setting the command speed (Profile Velocity: 6081h), acceleration time constant (Point Table No. 1: Acceleration: 2801h/Profile Acceleration: 6083h), deceleration time constant (Point Table No. 1: Deceleration: 2801h/Profile Deceleration: 6084h), and software limit (Software Position Limit: 607Dh), start the operation with the control command (Controlword: 6040h). The servo motor starts rotating at a specified speed. The current servo motor status can be checked with the control status (Statusword: 6041h).

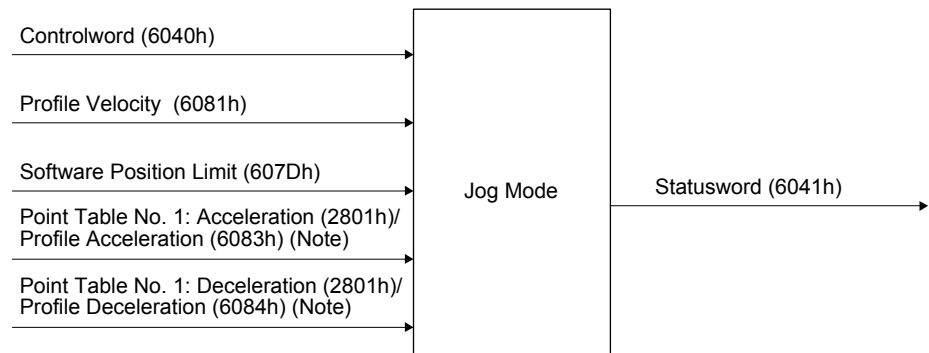

Note. For the point table method ([Pr. PA01] = ___ 6), set the acceleration time constant to Point Table No. 1: Acceleration (2801h), and the deceleration time constant to Point Table No. 1: Deceleration (2801h).

For the program method ([Pr. PA01] = ___ 7), set the acceleration time constant to Profile Acceleration: 6083h, and the deceleration time constant to Profile Deceleration: 6084h.

5.4.2 Related registers

Address	Name	Data type	Read/write	No. of points/ No. of registers	Continuous read/ continuous write	
6040h	Controlword	2 bytes	Read/write	1	Impossible	
6081h	Profile Velocity	4 bytes	Read/write	2	Impossible	
6083h	Profile Acceleration (Note)	4 bytes	Read/write	2	Impossible	
6084h	Profile Deceleration (Note)	4 bytes	Read/write	2	Impossible	
2801h	Point Table No.1	Number of entries	1 byte	Read/write	9	Impossible
		Point data	4 bytes			
		Speed	2 bytes			
		Acceleration (Note)	2 bytes			
		Deceleration (Note)	2 bytes			
		Dwell	2 bytes			
		Auxiliary	1 byte			
Reserved	1 byte					
607Dh	Software Position Limit	Number of entries	1 byte	Read/write	5	Impossible
		Min Position Limit	4 bytes			
		Max Position Limit	4 bytes			
6041h	Statusword	2 bytes	Read	1	Impossible	

Note. For the point table method ([Pr. PA01] = ___ 6), set the acceleration time constant to Point Table No. 1: Acceleration (2801h), and the deceleration time constant to Point Table No. 1: Deceleration (2801h).

For the program method ([Pr. PA01] = ___ 7), set the acceleration time constant to Profile Acceleration: 6083h, and the deceleration time constant to Profile Deceleration: 6084h.

5. DRIVING MOTOR

5.4.3 Details of registers

(1) Control command (Controlword: 6040h)

Address	Name	Data type	Read/write	No. of points/ No. of registers	Continuous read/ continuous write
6040h	Controlword	2 bytes	Read/write	1	Impossible

The status of the current control command input can be checked using the function code "03h" (Read Holding Registers).

A control command can be written using the function code "10h" (Preset Multiple Registers).

The bits of this register that relate to the JOG operation are shown below.

Bit	Description
0 to 3	Refer to section 5.1.3.
4	Rotation Start
5	Direction
6	Reserved (Note)
7	Refer to section 5.1.3.
8	Halt
9 to 15	Refer to section 5.1.3.

Note. The value at reading is undefined. Set "0" at writing.

The servo motor can be started with bit 4 (Rotation Start) of the control command (6040h).

If "1" is set, the servo motor starts rotating. If "0" is set, the servo motor stops.

The rotation direction of the servo motor can be set with bit 5 of (Direction) of the control command (6040h).

The servo motor rotates in the forward direction if "0" is set, and in the reverse direction if "1" is set. If the direction of the rotation is reversed while the servo motor is rotating, the servo motor once stops and then starts rotating in the opposite direction.

Use bit 8 (Halt) of the control command (6040h) to forcibly stop the servo motor.

If "1" is set, a deceleration stop is performed. If "0" is set, the operation resumes.

(2) Command speed (Profile Velocity: 6081h)

Address	Name	Data type	Read/write	No. of points/ No. of registers	Continuous read/ continuous write
6081h	Profile Velocity	4 bytes	Read/write	2	Impossible

The current speed command value can be read using the function code "03h" (Read Holding Registers).

A speed command value can be set using the function code "10h" (Preset Multiple Registers). Set a value in units of r/min.

(3) Acceleration time constant (Profile Acceleration: 6083h)

Address	Name	Data type	Read/write	No. of points/ No. of registers	Continuous read/ continuous write
6083h	Profile Acceleration	4 bytes	Read/write	2	Impossible

The current acceleration time constant can be read using the function code "03h" (Read Holding Registers).

An acceleration time constant can be set using the function code "10h" (Preset Multiple Registers). Set the length of time until the servo motor accelerates to the rated speed in units of ms.

5. DRIVING MOTOR

(4) Deceleration time constant (Profile Deceleration: 6084h)

Address	Name	Data type	Read/write	No. of points/ No. of registers	Continuous read/ continuous write
6084h	Profile Deceleration	4 bytes	Read/write	2	Impossible

The current deceleration time constant can be read using the function code "03h" (Read Holding Registers).

A deceleration time constant can be set using the function code "10h" (Preset Multiple Registers). Set the length of time until the servo motor decelerates from the rated speed to a stop in units of ms.

(5) Software limit (Software Position Limit: 607Dh)

Address	Name	Data type	Read/write	No. of points/ No. of registers	Continuous read/ continuous write	
607Dh	Software Position Limit	Number of entries	1 byte	Read/write	5	Impossible
		Min Position Limit	4 bytes			
		Max Position Limit	4 bytes			

The current software limit setting value can be read using the function code "03h" (Read Holding Registers).

At this time, "02h" is returned to Number of entries.

The stroke limit value in the reverse direction is returned to Min Position Limit (stroke limit -) in units of commands.

The stroke limit value in the forward direction is returned to Max Position Limit (stroke limit +) in units of commands.

The current software limit setting can be written using the function code "10h" (Preset Multiple Registers).

At this time, set "02h" for Number of entries.

Set the stroke limit value in the reverse direction in Min Position Limit (stroke limit -) in units of commands.

Set the stroke limit value in the forward direction in Max Position Limit (stroke limit +) in units of commands.

If Min Position Limit (stroke limit -) and Max Position Limit (stroke limit +) are set to the same value, the software limit function is disabled.

5. DRIVING MOTOR

(6) Control status (Statusword: 6041h)

Address	Name	Data type	Read/write	No. of points/ No. of registers	Continuous read/ continuous write
6041h	Statusword	2 bytes	Read	1	Impossible

The current control status can be checked using the function code "03h" (Read Holding Registers). The bits of this register that relate to the JOG operation are shown below.

Bit	Description
0 to 9	Refer to section 5.1.3.
10	Target reached
11	Refer to section 5.1.3.
12 to 13	Reserved (Note)
14 to 15	Refer to section 5.1.3.

Note. The value at reading is undefined.

During a JOG operation, "0" is returned to bit 10 (Target reached) of the control status (6041h). While the servo motor is being stopped, "1" is returned.

If bit 8 (Halt) of the control command (6040h) is set to "1", bit 10 turns on (1) when a deceleration stop is completed.

(7) Point table setting (Point Table No. 1: 2801h)

Refer to section 4.4 for the setting of the point table.

5. DRIVING MOTOR

5.4.4 Directions for use

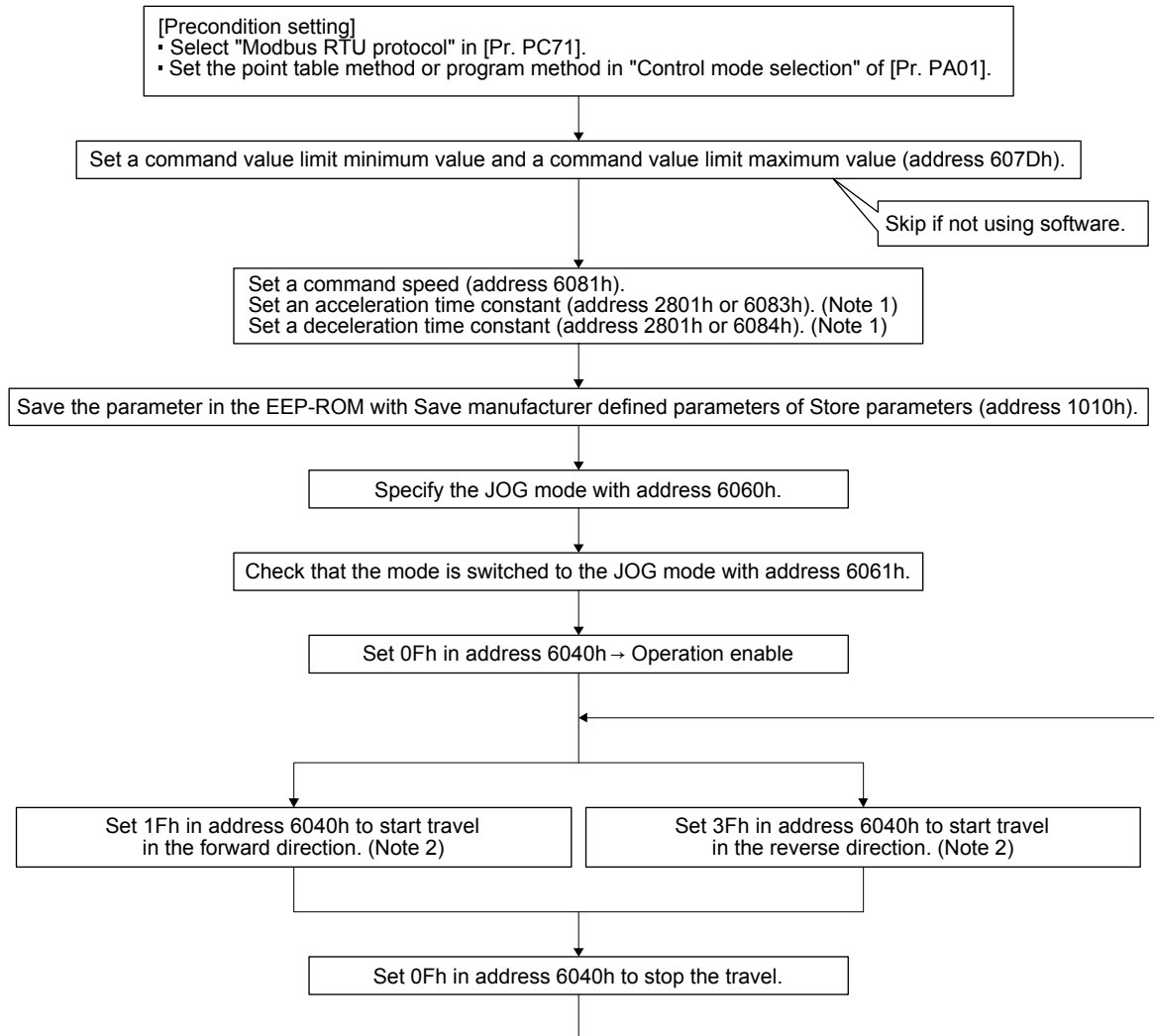

- Note 1. For the point table method ([Pr. PA01] = ___ 6), set the acceleration time constant to Point Table No. 1: Acceleration (2801h), and the deceleration time constant to Point Table No. 1: Deceleration (2801h).
For the program method ([Pr. PA01] = ___ 7), set the acceleration time constant to Profile Acceleration: 6083h, and the deceleration time constant to Profile Deceleration: 6084h.
- Note 2. [The operations are performed when [Pr. PT01] (address 2481h) is set to "___ 1" (incremental value command method).
When [Pr. PT01] (address 2481h) is set to "___ 0" (absolute value command method), setting 1Fh in address 6040h starts travel to the target position.

5. DRIVING MOTOR

5.5 Point Table Operation Mode

This section describes how to perform a point table data operation.

5.5.1 Function description

Perform a point table data operation following the instruction below.

After setting the point table (Point Table: 2801h to 281Fh), point table specification (Target Point Table: 2D60h), and Software Position Limit (607Dh), start the operation with the control command (Controlword: 6040h). The point table operation is performed. During a point table operation, the current status can be acquired with the control status (Statusword: 6041h), the point table number used for the current operation can be acquired with the point table request (Point Demand Value: 2D68h), and the latest point number on which the operation is completed can be acquired with the current point table (Point Actual Value: 2D69h).

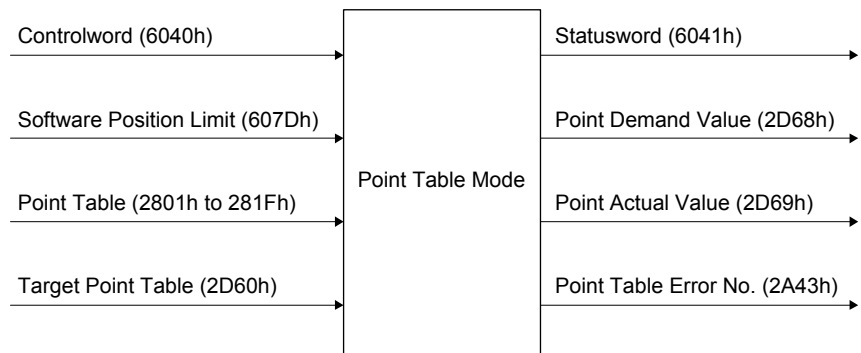

5.5.2 Related registers

Address	Name	Data type	Read/write	No. of points/ No. of registers	Continuous read/ continuous write
6040h	Controlword	2 bytes	Read/write	1	Impossible
607Dh	Software Position Limit	Number of entries	Read/write	5	Impossible
		Min Position Limit			
		Max Position Limit			
2801h to 281Fh	Point Table No. 1 to No. 31 (Point table No. 1 to No. 31)	Number of entries	Read/write	9	Impossible
		Point data			
		Speed			
		Acceleration			
		Deceleration			
		Dwell			
		Sub function			
		M code (Note)			
2D60h	Target Point Table	2 bytes	Read/write	1	Impossible
6041h	Statusword	2 bytes	Read/write	1	Impossible
2D68h	Point Demand Value	2 bytes	Read/write	1	Impossible
2D69h	Point Actual Value	2 bytes	Read/write	1	Impossible
2A43h	Point Table Error	Number of entries	Read	4	Impossible
		Point Table Error No.			
		Point Table Error Factor			

Note. M code will be available in the future.

5. DRIVING MOTOR

5.5.3 Details of registers

(1) Control command (Controlword: 6040h)

Address	Name	Data type	Read/write	No. of points/ No. of registers	Continuous read/ continuous write
6040h	Controlword	2 bytes	Read/write	1	Impossible

The status of the current control command input can be checked using the function code "03h" (Read Holding Registers).

A control command can be written using the function code "10h" (Preset Multiple Registers).

The bits of this register that relate to the point table operation are shown below.

Bit	Description
0 to 3	Refer to section 5.1.3.
4	New Set Point
5	Direction
6	Reserved (Note)
7	Refer to section 5.1.3.
8	Halt
9 to 15	Refer to section 5.1.3.

Note. The value at reading is undefined. Set "0" at writing.

Use bit 4 (New Set Point) of the control command (6040h) to apply point table data.

If "1" is set, new point table data is applied. To restart the operation after the servo motor is stopped, set "0" before setting "1" again.

For [Pr. PT01] (address 2481h) = "___ 1" (incremental value command method), the rotation direction of the servo motor can be set with bit 5 of (Direction) of the control command (6040h).

The servo motor rotates in the forward direction if "0" is set, and in the reverse direction if "1" is set. If the direction of the rotation is reversed while the servo motor is rotating, the servo motor once stops and then starts rotating in the opposite direction.

Use bit 8 (Halt) of the control command (6040h) to forcibly stop the servo motor.

If "1" is set, a deceleration stop is performed. If "0" is set, the operation resumes.

(2) Software limit (Software Position Limit: 607Dh)

Address	Name	Data type	Read/write	No. of points/ No. of registers	Continuous read/ continuous write
607Dh	Software Position Limit	Number of entries	1 byte	Read/write	5
		Min Position Limit	4 bytes		
		Max Position Limit	4 bytes		
					Impossible

The current software limit setting value can be read using the function code "03h" (Read Holding Registers).

At this time, "02h" is returned to Number of entries.

The stroke limit value in the reverse direction is returned to Min Position Limit (stroke limit -) in units of commands.

The stroke limit value in the forward direction is returned to Max Position Limit (stroke limit +) in units of commands.

5. DRIVING MOTOR

The current software limit setting can be written using the function code "10h" (Preset Multiple Registers).

At this time, set "02h" for Number of entries.

Set the stroke limit value in the reverse direction in Min Position Limit (stroke limit -) in units of commands.

Set the stroke limit value in the forward direction in Max Position Limit (stroke limit +) in units of commands.

If Min Position Limit (stroke limit -) and Max Position Limit (stroke limit +) are set to the same value, the software limit function is disabled.

(3) Point table setting (Point Table No. 1 to No. 31: 2801h to 281Fh)

For the setting method, refer to Section 4.4.

Address	Name	Data type	Read/write	No. of points/ No. of registers	Continuous read/ continuous write	
2801h to 281Fh	Point Table No. 1 to No. 31	Number of entries	1 byte	Read/write	9	Impossible
		Point data	4 bytes			
		Speed	2 bytes			
		Acceleration	2 bytes			
		Deceleration	2 bytes			
		Dwell	2 bytes			
		Sub function	1 byte			
		M code (Note)	1 byte			

Note. M code will be available in the future.

(4) Point table specification (Target Point Table: 2D60h)

Address	Name	Data type	Read/write	No. of points/ No. of registers	Continuous read/ continuous write
2D60h	Target Point Table	2 bytes	Read/write	1	Impossible

The point table specification number can be read using the function code "03h" (Read Holding Registers).

A point table specification number can be set using the function code "10h" (Preset Multiple Registers).

(5) Control status (Statusword: 6041h)

Address	Name	Data type	Read/write	No. of points/ No. of registers	Continuous read/ continuous write
6041h	Statusword	2 bytes	Read/write	1	Impossible

The current point table operation status can be read using the function code "03h" (Read Holding Registers).

The bits of this register that relate to the point table operation are shown below.

Bit	Description
0 to 9	Refer to section 5.1.3.
10	Target reached
11	Refer to section 5.1.3.
12	Set Point Acknowledge
13	Reserved (Note)
14 to 15	Refer to section 5.1.3.

Note. The value at reading is undefined. Set "0" at writing.

5. DRIVING MOTOR

(a) Bit 10 of the control status (6041h) (Target reached)

Bit 10 turns on (1) when the command position is reached. If bit 8 (Halt) of the control command is set to "1", bit 10 turns on (1) when a deceleration stop is completed.

If a command is input again, bit 10 turns off (0).

(b) Bit 12 (Set Point Acknowledge) of the control status (6041h)

When bit 4 of the control command (6040h) is set to "1" and the servo amplifier completes accepting the command, bit 12 turns on (1).

(6) Point table request (Point Demand Value: 2D68h)

Address	Name	Data type	Read/write	No. of points/ No. of registers	Continuous read/ continuous write
2D68h	Point Demand Value	2 bytes	Read/write	1	Impossible

The currently commanded point table number can be read using the function code "03h" (Read Holding Registers).

While the servo motor is being stopped, the value of the point table specification (Target Point Table: 2D60h) is returned.

(7) Current point table (Point Actual Value: 2D69h)

Address	Name	Data type	Read/write	No. of points/ No. of registers	Continuous read/ continuous write
2D69h	Point Actual Value	2 bytes	Read/write	1	Impossible

The point table number on which the operation is already completed is read using the function code "03h" (Read Holding Registers).

When a home position return operation is completed, "0" is returned.

(8) Point table error (Point Table Error: 2A43h)

When a point table setting error occurs, the point table number and setting item that have caused the error are returned. For the reading method, refer to Section 4.13.

Address	Name	Data type	Read/write	No. of points/ No. of registers	Continuous read/ continuous write	
2A43h	Point Table Error	Number of entries	Read	4	Impossible	
		Point Table Error No.				1 byte
		Point Table Error Factor				2 bytes
		4 bytes				

5. DRIVING MOTOR

5.5.4 Directions for use

(1) For operation that uses point table data saved in the EEPROM

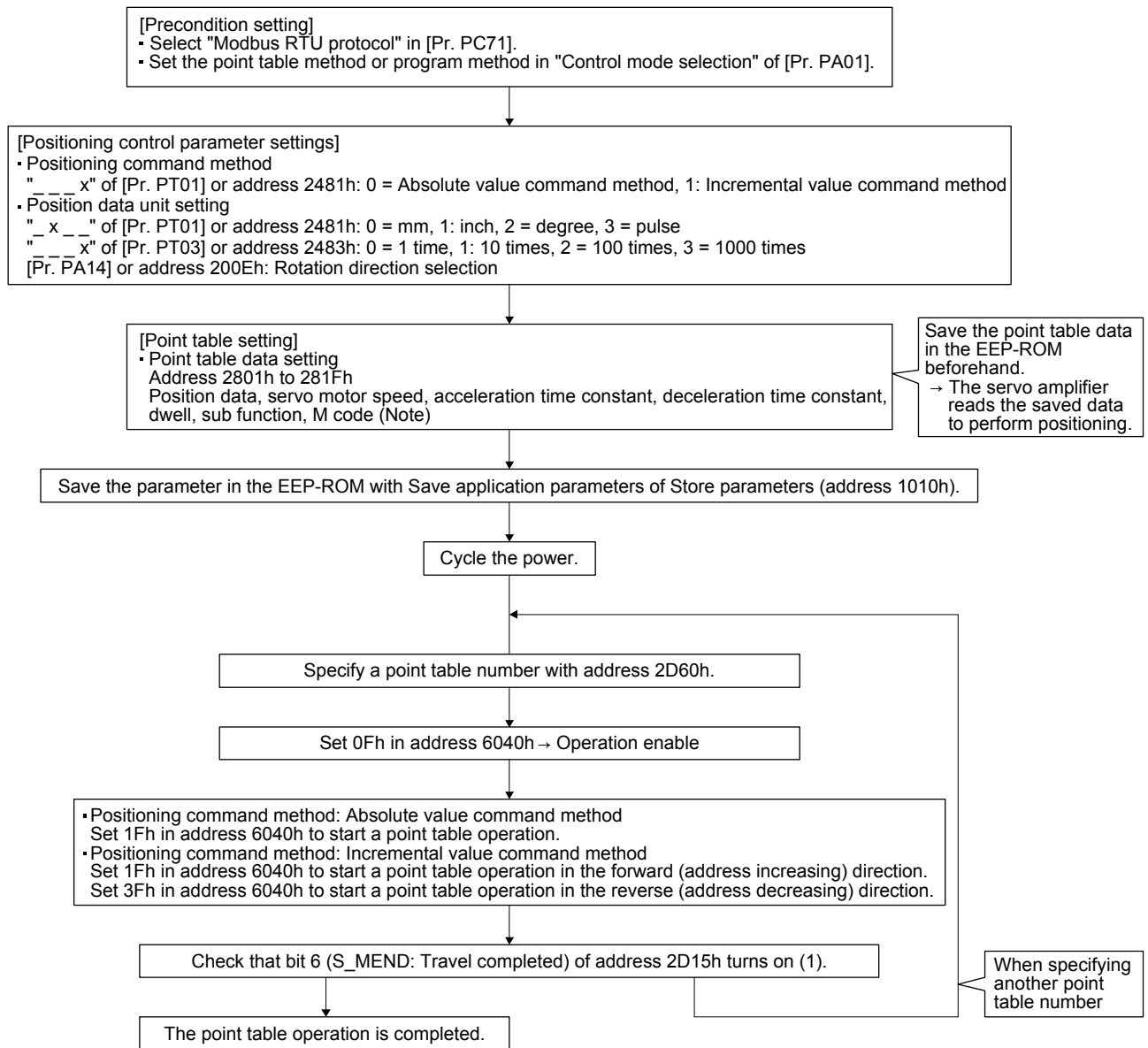

Note. M code will be available in the future.

5. DRIVING MOTOR

- (2) For operation that uses point table data sequentially sent to the servo amplifier (Method of saving point table data in RAM)

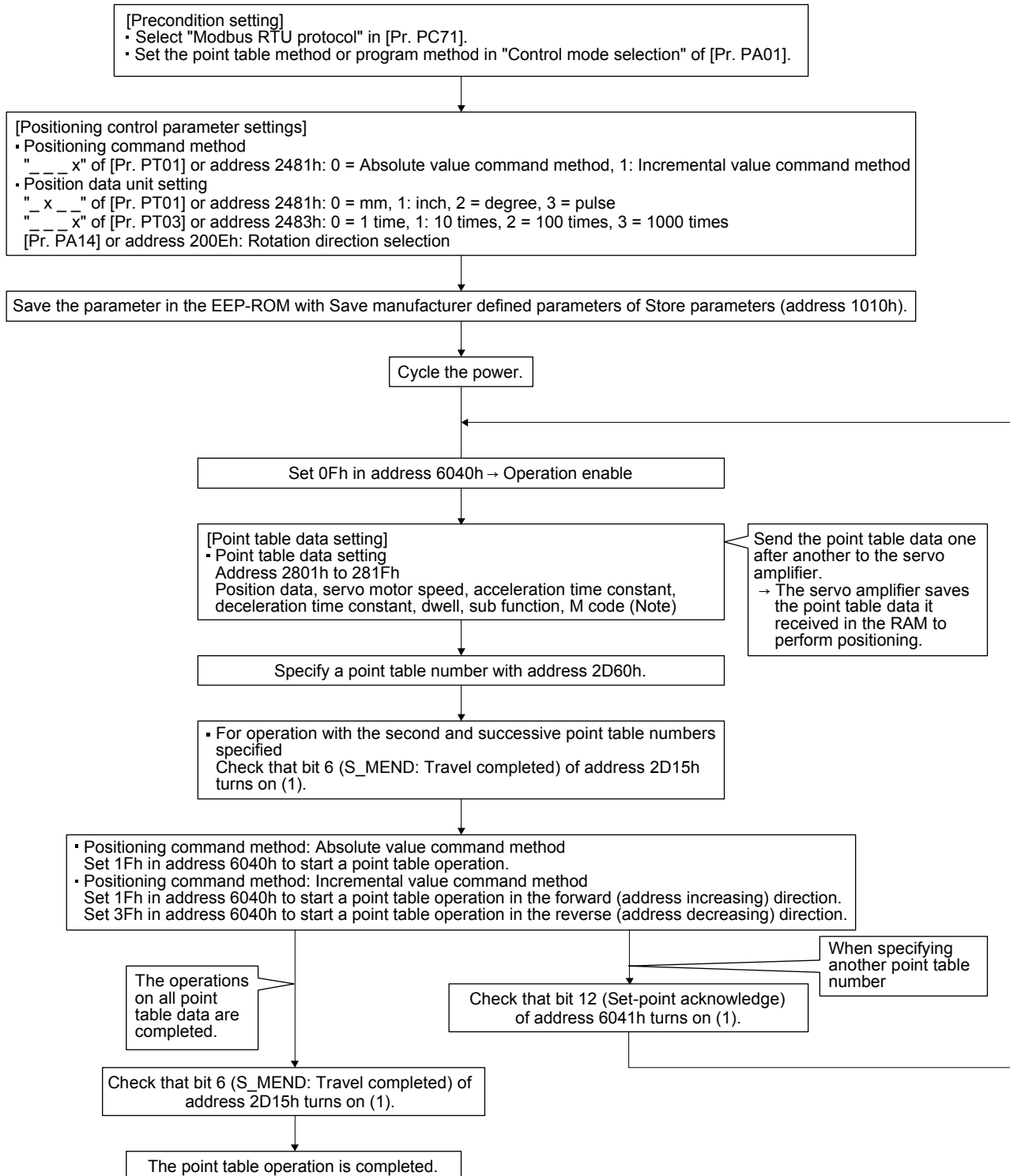

Note. M code will be available in the future.

5. DRIVING MOTOR

5.6 Program Operation Mode

This section describes how to perform a program operation.

5.6.1 Function description

Set a program beforehand, and then set a program number in the program number specification (Target Program No.: 2D70h) and start the operation with the control command (Controlword: 6040h). The specified program starts running.

The current status can be checked with the control status (Statusword: 6041h).

The currently running program number can be read with the program number request (Program No. Demand Value: 2D78h). The current step number can be read with the program step number (Program Step No.: 2D79h).

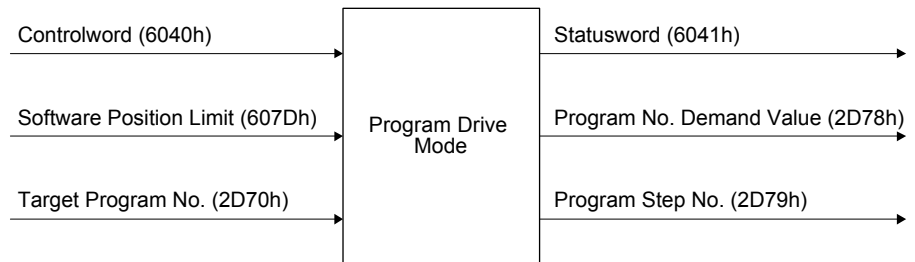

5.6.2 Related registers

Address	Name	Data type	Read/write	No. of points/ No. of registers	Continuous read/ continuous write	
6040h	Controlword	2 bytes	Read/write	1	Impossible	
607Dh	Software Position Limit	Number of entries	1 byte	Read/write	5	Impossible
		Min Position Limit	4 bytes			
		Max Position Limit	4 bytes			
2D70h	Target Program No.	2 bytes	Read/write	1	Impossible	
6041h	Statusword	2 bytes	Read	1	Impossible	
2D78h	Program No. Demand Value	2 bytes	Read	1	Impossible	
2D79h	Program Step No.	2 bytes	Read	1	Impossible	

5. DRIVING MOTOR

5.6.3 Details of registers

(1) Control command (Controlword: 6040h)

Address	Name	Data type	Read/write	No. of points/ No. of registers	Continuous read/ continuous write
6040h	Controlword	2 bytes	Read/write	1	Impossible

The status of the current control command input can be checked using the function code "03h" (Read Holding Registers).

A control command can be written using the function code "10h" (Preset Multiple Registers).

The bits of this register that relate to the program operation are shown below.

Bit	Description
0 to 3	Refer to section 5.1.3.
4	New Set Program
5	Reserved (Note)
6	Stop
7	Refer to section 5.1.3.
8	Halt
9 to 15	Refer to section 5.1.3.

Note. The value at reading is undefined. Set "0" at writing.

Use bit 4 (New Set Program) of the control command (6040h) to start a program operation.

When the bit is set to "1", the specified program number setting takes effect. To restart the operation after the servo motor is stopped, set "0" before setting "1" again.

If "1" is set to bit 6 (Stop) of the control command (6040h), the program ends during the processing.

Use bit 8 (Halt) of the control command (6040h) to forcibly stop the servo motor.

If "1" is set, a deceleration stop is performed. If "0" is set, the operation resumes. However, a deceleration stop is not performed when the ZRT command is executed.

(2) Software limit (Software Position Limit: 607Dh)

Address	Name	Data type	Read/write	No. of points/ No. of registers	Continuous read/ continuous write	
607Dh	Software Position Limit	Number of entries	1 byte	Read/write	5	Impossible
		Min Position Limit	4 bytes			
		Max Position Limit	4 bytes			

The current software limit setting value can be read using the function code "03h" (Read Holding Registers).

At this time, "02h" is returned to Number of entries.

The stroke limit value in the reverse direction is returned to Min Position Limit (stroke limit -) in units of commands.

The stroke limit value in the forward direction is returned to Max Position Limit (stroke limit +) in units of commands.

5. DRIVING MOTOR

The current software limit setting can be written using the function code "10h" (Preset Multiple Registers).

At this time, set "02h" for Number of entries.

Set the stroke limit value in the reverse direction in Min Position Limit (stroke limit -) in units of commands.

Set the stroke limit value in the forward direction in Max Position Limit (stroke limit +) in units of commands.

If Min Position Limit (stroke limit -) and Max Position Limit (stroke limit +) are set to the same value, the software limit function is disabled.

(3) Program number specification (Target Program No.: 2D70h)

Address	Name	Data type	Read/write	No. of points/ No. of registers	Continuous read/ continuous write
2D70h	Target Program No.	2 bytes	Read/write	1	Impossible

The currently specified program number can be read using the function code "03h" (Read Holding Registers).

A program number can be set using the function code "10h" (Preset Multiple Registers).

(4) Control status (Statusword: 6041h)

Address	Name	Data type	Read/write	No. of points/ No. of registers	Continuous read/ continuous write
6041h	Statusword	2 bytes	Read	1	Impossible

The current program operation status can be read using the function code "03h" (Read Holding Registers).

The bits of this register that relate to the program operation are shown below.

Bit	Description
0 to 9	Refer to section 5.1.3.
10	Target reached
11	Refer to section 5.1.3.
12	Program Running
13	Reserved (Note)
14 to 15	Refer to section 5.1.3.

Note. The value at reading is undefined.

(a) Bit 10 of the control status (6041h) (Target reached)

Bit 10 turns on (0) when the start signal turns on. Bit 10 turns on (1) when the command position is reached. If bit 8 (Halt) of the control command is set to "1", bit 10 turns on (1) when a deceleration stop is completed.

(b) Bit 12 (Program Running) of the control status (6041h)

During a program operation, bit 12 is on (1). When the program stops running or has ended, the bit turns off (0).

5. DRIVING MOTOR

(5) Program number request (Program No. Demand Value: 2D78h)

Address	Name	Data type	Read/write	No. of points/ No. of registers	Continuous read/ continuous write
2D78h	Program No. Demand Value	2 bytes	Read	1	Impossible

The currently commanded program number can be read using the function code "03h" (Read Holding Registers).

While the servo motor is being stopped, the value set for the program number specification (Target Program No.: 2D70h) is returned.

(6) Program step number (Program Step No.: 2D79h)

Address	Name	Data type	Read/write	No. of points/ No. of registers	Continuous read/ continuous write
2D79h	Program Step No.	2 bytes	Read	1	Impossible

The currently running program step number can be read using the function code "03h" (Read Holding Registers).

While no program is running, "0" is returned.

5.6.4 Directions for use

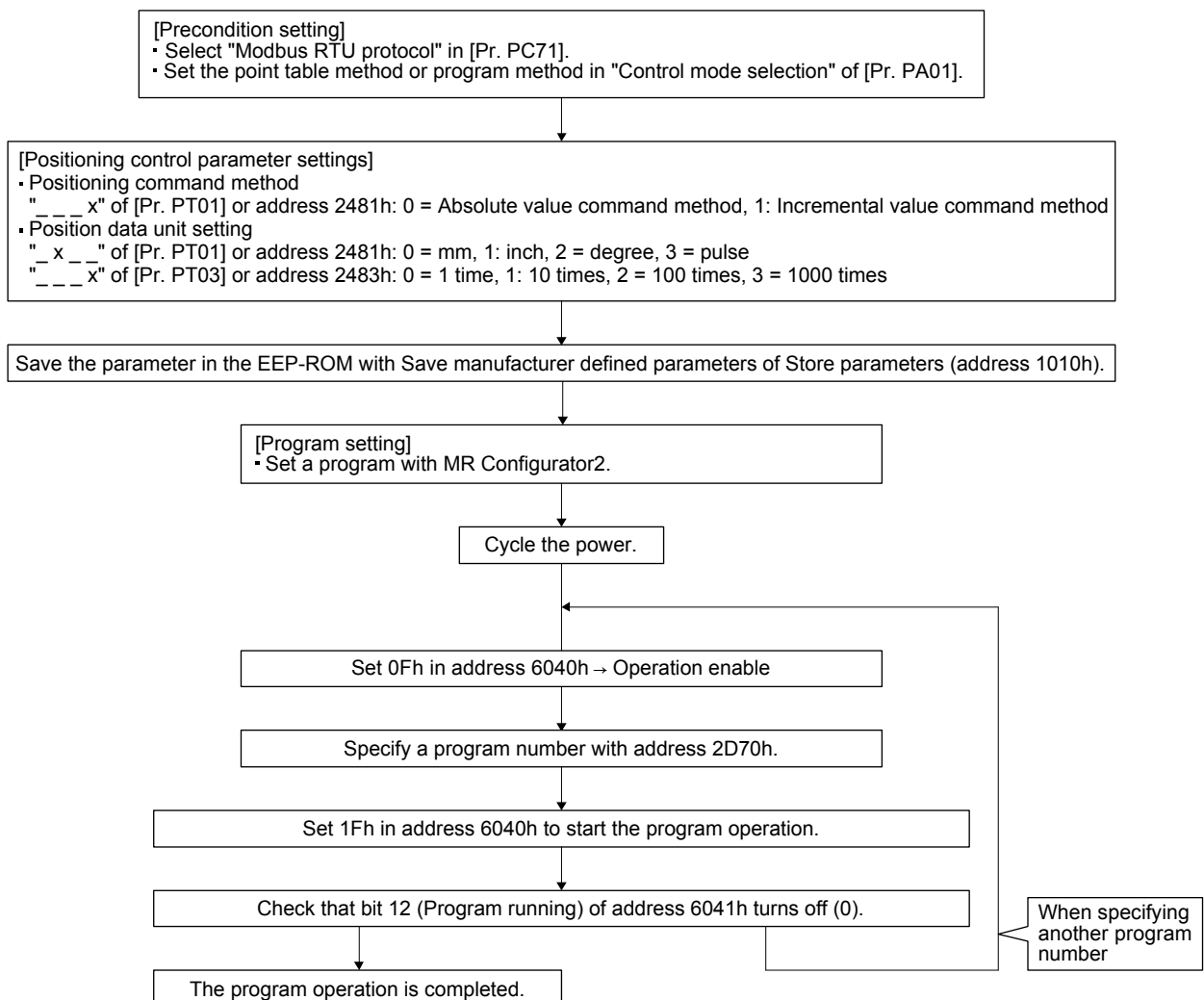

5. DRIVING MOTOR

5.7 Touch Probe (Address: 60B8h to 60BBh)

The current position latch data at the time of MSD (Mark detection) input can be read.

5.7.1 Function description

When the touch probe function (60B8h) is set, and MSD (Mark detection), an external signal, is turned on/off, the current position at the rising and falling edges are latched.

The latch status of the current position data can be checked with the touch probe status (60B9h). The latched current data can be read with the touch probe position positive value (60BAh) and the touch probe position negative value (60BBh).

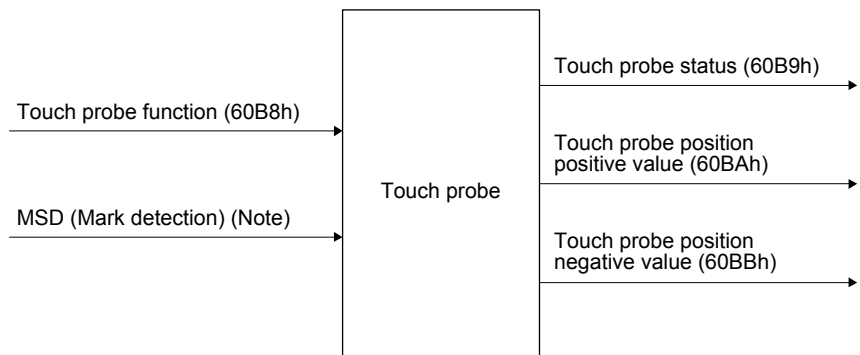

Note. Input with an external signal.

5.7.2 List of registers

Address	Name	Data type	Read/write	No. of points/ No. of registers	Continuous read/ continuous write
60B8h	Touch probe function	2 bytes	Read/write	1	Possible
60B9h	Touch probe status	2 bytes	Read	1	Possible
60BAh	Touch probe position positive value	4 bytes	Read	2	Possible
60BBh	Touch probe position negative value	4 bytes	Read	2	Possible

5. DRIVING MOTOR

5.7.3 Details of registers

(1) Touch probe function setting (Touch probe function: 60B8h)

Address	Name	Data type	Read/write	No. of points/ No. of registers	Continuous read/ continuous write
60B8h	Touch probe function	2 bytes	Read/write	1	Possible

The current setting of the touch probe function can be checked using function code "03h" (Read Holding Registers).

The touch probe function is set using function code "10h" (Preset Multiple Registers). The following table lists the setting of this register.

Bit	Description
0	0: Latch function disabled 1: Latch function enabled
1	0: Latch with the first trigger 1: Continuously latch with trigger inputs
2	The value at reading is undefined. Set "0" when writing.
3	
4	0: Stop sampling at the rising edge of touch probe 1: Start sampling at the rising edge of touch probe
5	0: Stop sampling at the falling edge of touch probe 1: Start sampling at the falling edge of touch probe
6 to 15	The value at reading is undefined. Set "0" when writing.

Select enable/disable for the latch function with bit 0. Select "1" when using the touch probe function. Select a trigger condition for the touch probe function with bit 1. Set "0" to latch just once when MSD (Mark detection) is input. Set "1" to latch every time MSD (Mark detection) is input.

Set a condition for the rising edge of the MSD (Mark detection) with bit 4. Set "1" to latch at the rising edge.

Set a condition for the falling edge of the MSD (Mark detection) with bit 5. Set "1" to latch at the falling edge.

5. DRIVING MOTOR

(2) Status of the touch probe function (Touch probe status: 60B9h)

Address	Name	Data type	Read/write	No. of points/ No. of registers	Continuous read/ continuous write
60B9h	Touch probe status	2 bytes	Read	1	Possible

The current status of the touch probe function can be checked using function code "03h" (Read Holding Registers). The following table lists the setting of this register.

Bit	Description
0	0: Latch function of touch probe is disabled. 1: Latch function of touch probe is enabled.
1 (Note)	0: Latch is incomplete at the rising edge with the latch function of the touch probe. 1: Latch is complete at the rising edge with the latch function of the touch probe.
2 (Note)	0: Latch is incomplete at the falling edge with the latch function of the touch probe. 1: Latch is complete at the falling edge with the latch function of the touch probe.
3 to 5	The value at reading is undefined.
6	MSDH (Latch completed at rising edge of Mark detection) status 0: Latch is incomplete at the rising edge with the latch function of the touch probe. 1: Latch is complete at the rising edge with the latch function of the touch probe.
7	MSDL (Latch completed at falling edge of Mark detection) status 0: Latch is incomplete at the falling edge with the latch function of the touch probe. 1: Latch is complete at the falling edge with the latch function of the touch probe.
8 to 15	The value at reading is undefined.

Note. This is available with servo amplifiers with software version C1 or later.

Bit 0 indicates the status of the touch probe function. 0 indicates disabled, and 1 enabled.

With bit 1, if the data is latched at the rising edge of the touch probe can be checked. Latched data can be read when this bit is set to "1". When this bit turns on, it remains on until bit 4 of the touch probe setting (60B8h) is set to "0".

With bit 2, if the data is latched at the falling edge of the touch probe can be checked. Latched data can be read when this bit is set to "1". When this bit turns on, it remains on until bit 5 of the touch probe setting (60B8h) is set to "0".

Bit 6 indicates the status of MSDH (Latch completed at rising edge of Mark detection). When bit 0 is set to "1" and bit 6 is set to "1", the position of the touch probe rising edge is updated.

Bit 7 indicates the status of MSDH (Latch completed at falling edge of Mark detection). When bit 0 is set to "1" and bit 7 is set to "1", the position of the touch probe falling edge is updated.

(3) Rising edge position of touch probe (Touch probe position positive value: 60BAh)

Address	Name	Data type	Read/write	No. of points/ No. of registers	Continuous read/ continuous write
60BAh	Touch probe position positive value	4 bytes	Read	2	Possible

The current position of the touch probe rising edge can be checked using function code "03h" (Read Holding Registers).

5. DRIVING MOTOR

(4) Falling edge position of touch probe (Touch probe position negative value: 60BBh)

Address	Name	Data type	Read/write	No. of points/ No. of registers	Continuous read/ continuous write
60BBh	Touch probe position negative value	4 bytes	Read	2	Possible

The current position of the touch probe falling edge can be checked using function code "03h" (Read Holding Registers).

5.7.4 Directions for use

The following explains for latching the current position at the rising edge of MSD (Mark detection).

- (1) Set "0013h" to the touch probe setting (Touch probe function: 60B8h) to store data at rising edge of MSD (Mark detection).
- (2) At this time, the touch probe status (Touch probe status: 60B9h) is set to "0001h", and the latched data has not been stored yet.
- (3) Turn on MSD (Mark detection) with an external signal.
- (4) The touch probe status (Touch probe status: 60B9h) changes to "0043h", and the current position at the time of MSD (Mark detection) on will be stored to the rising edge position of touch probe (Touch probe position positive value: 60BAh).
- (5) Turn off MSD (Mark detection) with an external signal.
- (6) The touch probe status (Touch probe status: 60B9h) changes to "0083h", and the current position at the time of MSD (Mark detection) off will not be stored to the falling edge position of touch probe (Touch probe position negative value: 60BBh).
- (7) Latching can be continued from (3).

5. DRIVING MOTOR

The following shows a timing chart.

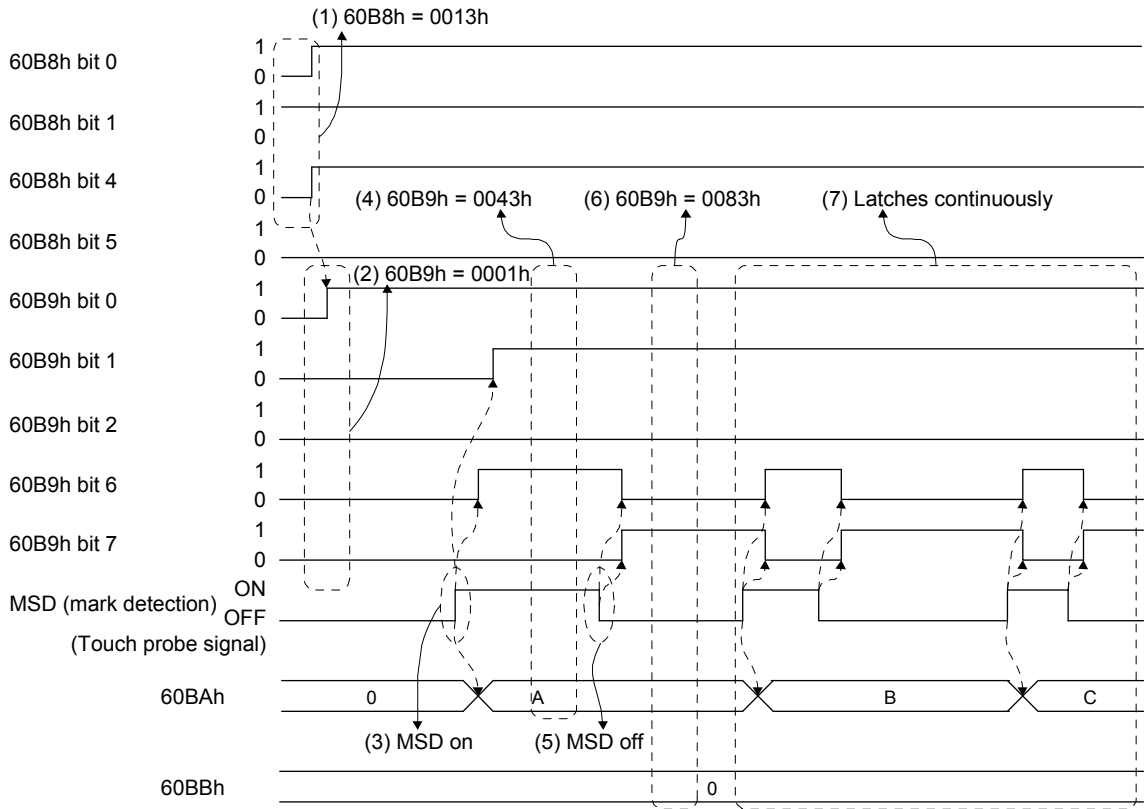

5. DRIVING MOTOR

5.8 Function common to the modes

This section describes the registers that can be used for the home position return mode, JOG mode, point table mode, and program operation mode.

5.8.1 List of registers

Function	Description	Read/write	Detailed explanation
Control input (2D01h to 2D09h)	The control input of the servo amplifier can be specified.	Read/write	Section 5.8.2
Control output (2D11h to 2D19h)	The control output status of the servo amplifier can be read.	Read	Section 5.8.3
Simultaneous start bit setting (2D9Ah)	Bit 4 of the control command (Controlword: 6040h) can be set.	Writing	Section 5.8.4
Controller force stop (2D9Bh)	The controller force stop can be specified.	Writing	Section 5.8.5
Override (2DB0h)	An override value can be set.	Read/write	Section 5.8.6
Forward torque limit value (60E0h)	The torque limit value for the forward operation can be set.	Read/write	Section 5.8.7
Reverse torque limit value (60E1h)	The torque limit value for the reverse operation can be set.	Read/write	Section 5.8.8
Current position (6064h)	The current position can be read.	Read	Section 5.8.9
Current speed (606Ch)	The current speed can be read.	Read	Section 5.8.10
Current torque (6077h)	The current torque can be read.	Read	Section 5.8.11
Cam number setting (2D80h)	A cam number can be set.	Read/write	Section 5.8.12
Current cam number (2D82h)	The cam number being used in the cam control operation can be read.	Read	Section 5.8.13
Cam axis one-cycle length setting (2D84h)	One-cycle length of a cam axis can be written in the RAM space in the servo amplifier.	Read/write	Section 5.8.14
Cam stroke length setting (2D85h)	The cam stroke length can be written in the RAM space in the servo amplifier.	Read/write	Section 5.8.15
Request store CAM (2D88h)	Cam data can be written in the RAM space in the servo amplifier.	Writing	Section 5.8.16
CAM area (2D89h)	The storage area for cam data to be read or written can be set.	Read/write	Section 5.8.17
CAM data in CAM area (2D8Bh)	Cam data in the area specified by using the CAM area (2D89h) can be read or written.	Read/write	Section 5.8.18

5.8.2 Control input (2D01h to 2D09h)

Address	Name	Data type	Read/write	No. of points/ No. of registers	Continuous read/ continuous write
2D01h to 2D09h	Control DI1 to Control DI9	2 bytes	Read/write	1	Possible

The input device status (ON or OFF) can be read using the function code "03h" (Read Holding Registers). Input devices can be turned on or off using the function code "10h" (Preset Multiple Registers).

5. DRIVING MOTOR

The following table lists readable and writable input devices.

Bit definition of control DI1

Bit	Abbreviation	Description						
0	C_EM1/2	Forced stop 1/2						
1		The value at reading is undefined. Set "0" at writing.						
2								
3								
4	C_CDP		Gain switching					
5		The value at reading is undefined. Set "0" at writing.						
6								
7								
8	C_TL1		<p>Internal torque limit selection The smallest value among Object 60E0h/60E1h and the torque limits in the table below is applied as the torque limit value.</p> <table border="1"> <thead> <tr> <th>Bit 8</th> <th>Description</th> </tr> </thead> <tbody> <tr> <td>0</td> <td>Parameter 1</td> </tr> <tr> <td>1</td> <td>Parameter 1 and 2</td> </tr> </tbody> </table> <p>Parameter 1: [Pr. PA11], [Pr. PA12] Parameter 2: [Pr. PA35]</p>	Bit 8	Description	0	Parameter 1	1
Bit 8	Description							
0	Parameter 1							
1	Parameter 1 and 2							
9		The value at reading is undefined. Set "0" at writing.						
10								
11								
12								
13								
14								
15								

Bit definition of control DI2

Bit	Abbreviation	Description
0		The value at reading is undefined. Set "0" at writing.
1		
2		
3		
4		
5	C_CAMC	Cam control command
6		The value at reading is undefined. Set "0" at writing.
7		
8	C_PC	Proportional control
9		The value at reading is undefined. Set "0" at writing.
10		
11	C_CLTC (Note)	Clutch command
12		The value at reading is undefined. Set "0" at writing.
13	C_CPCD (Note)	Cam position compensation requirement
14		The value at reading is undefined. Set "0" at writing.
15		

Note. This is available with servo amplifiers with software version C1 or later.

5. DRIVING MOTOR

Bit definition of control DI3

Bit	Abbreviation	Description
0		The value at reading is undefined. Set "0" at writing.
1		
2	C_CM1	Electronic gear selection 1
3	C_CM2	Electronic gear selection 2
4		The value at reading is undefined. Set "0" at writing.
5		
6		
7		
8		
9		
10		
11	C_CR	Clear
12		The value at reading is undefined. Set "0" at writing.
13	C_STAB2	Second acceleration/deceleration selection
14		The value at reading is undefined. Set "0" at writing.
15		

Bit definition of control DI4

Bit	Abbreviation	Description
0		The value at reading is undefined. Set "0" at writing.
1		
2		
3		
4		
5		
6		
7		
8		
9		
10		
11		
12		
13		
14		
15		

5. DRIVING MOTOR

Bit definition of control DI5

Bit	Abbreviation	Description
0		The value at reading is undefined. Set "0" at writing.
1		
2		
3		
4		
5		
6		
7		
8		
9		
10		
11		
12		
13		
14		
15		

Bit definition of control DI6

Bit	Abbreviation	Description
0		The value at reading is undefined. Set "0" at writing.
1		
2		
3		
4		
5		
6		
7		
8		
9		
10		
11		
12		
13		
14		
15		

5. DRIVING MOTOR

Bit definition of control DI7

Bit	Abbreviation	Description
0	C_PI1	Program input 1
1	C_PI2	Program input 2
2	C_PI3	Program input 3
3	C_TCH	Teach
4	C_TP0	Generator multiplication 1
5	C_TP1	Generator multiplication 2
6		The value at reading is undefined. Set "0" at writing.
7	C_OVR	Analog override selection
8	C_LPS	Current position latch input
9		The value at reading is undefined. Set "0" at writing.
10	C_STAB	Speed acceleration/deceleration selection
11		The value at reading is undefined. Set "0" at writing.
12		
13		
14		
15		

Bit definition of control DI8

Bit	Abbreviation	Description
0		The value at reading is undefined. Set "0" at writing.
1		
2		
3		
4		
5		
6		
7		
8		
9		
10		
11		
12		
13		
14		
15		

5. DRIVING MOTOR

Bit definition of control DI9

Bit	Abbreviation	Description
0		The value at reading is undefined. Set "0" at writing.
1		
2		
3		
4		
5		
6		
7		
8		
9		
10		
11		
12		
13		
14		
15		

5.8.3 Control output (2D11h to 2D19h)

Address	Name	Data type	Read/write	No. of points/ No. of registers	Continuous read/ continuous write
2D11h to 2D19h	Status DO1 to Status DO9	2 bytes	Read	1	Possible

The output device status (ON or OFF) can be read using the function code "03h" (Read Holding Registers). The following table lists readable output devices.

Bit definition of status DO1

Bit	Abbreviation	Description
0		The value at reading is undefined.
1	S_ERF	EEP-ROM write completed 0: EEP-ROM write in process 1: EEP-ROM write completed
2	S_SA	Speed reached
3		The value at reading is undefined.
4	S_CDPS	Variable gain selection
5		The value at reading is undefined.
6		
7	S_TL	Analog torque limit selection in process
8	S_TL1	Torque limit selection in process
9		The value at reading is undefined.
10		
11		
12	S_INP	In-position
13	S_TLC	Limiting torque
14		The value at reading is undefined.
15		

5. DRIVING MOTOR

Bit definition of status DO2

Bit	Abbreviation	Description
0	S_ZPAS	Z-phase already passed
1		The value at reading is undefined.
2		
3	S_ZSP	
4	S_VLC	Under speed limit
5	S_CAMS	Under cam control
6		The value at reading is undefined.
7		
8	S_PC	
9		The value at reading is undefined.
10		
11	S_CLTS (Note)	
12	S_CLTSM (Note)	Clutch smoothing status
13	S_CPCC (Note)	Cam position compensation completed
14		The value at reading is undefined.
15		

Note. This is available with servo amplifiers with software version C1 or later.

Bit definition of status DO3

Bit	Abbreviation	Description
0		The value at reading is undefined.
1		
2		
3		
4		
5		
6		
7		
8		
9		
10		
11	S_MTTR	During tough drive
12		The value at reading is undefined.
13		
14		
15		

5. DRIVING MOTOR

Bit definition of status DO4

Bit	Abbreviation	Description
0		The value at reading is undefined.
1		
2		
3		
4		
5		
6		
7		
8		
9		
10		
11		
12		
13		
14		
15		

Bit definition of status DO5

Bit	Abbreviation	Description
0		The value at reading is undefined.
1		
2		
3		
4		
5	S_CPO	Rough match
6	S_MEND	Travel completed
7	S_ZP	Home position return operation completed
8	S_PUS	Pause
9		The value at reading is undefined.
10		
11		
12		
13		
14		
15		

5. DRIVING MOTOR

Bit definition of status DO6

Bit	Abbreviation	Description
0		The value at reading is undefined.
1		
2		
3		
4		
5		
6		
7		
8		
9		
10		
11		
12		
13		
14		
15		

Bit definition of status DO7

Bit	Abbreviation	Description
0	S_ALMWNG	Failure/warning
1		The value at reading is undefined.
2	S_POT	Position range output
3	S_PED	Position end
4	S_SOUT	SYNC synchronous output
5		The value at reading is undefined.
6	S_OUT1	Program output 1
7	S_OUT2	Program output 2
8	S_OUT3	Program output 3
9		The value at reading is undefined.
10		
11		
12		
13		
14		
15		

5. DRIVING MOTOR

Bit definition of status DO8

Bit	Abbreviation	Description
0		The value at reading is undefined.
1		
2		
3		
4		
5		
6		
7		
8		
9		
10		
11		
12		
13		
14		
15		

Bit definition of status DO9

Bit	Abbreviation	Description
0		The value at reading is undefined.
1		
2		
3		
4		
5		
6		
7		
8		
9		
10		
11		
12		
13		
14		
15		

5. DRIVING MOTOR

5.8.4 Simultaneous start bit setting (2D9Ah)

Multiple axis system with different operation modes (for example, point table operation and program operation) can be started simultaneously using the broadcast communication. This setting is not needed when the same operation mode is used.

(1) List of registers

Address	Name	Data type	Read/write	No. of points/ No. of registers	Continuous read/ continuous write
2D9Ah	Set Controlword bit4	1 byte	Writing	1	Impossible

(2) Usage

Before setting this register, set the following items for all stations to be started simultaneously, and prepare for simultaneous start.

- (a) Specify the point table No. or the program No.
- (b) Set "000Fh" or "002Fh" to register 6040h to make the servo amplifier status "Operation enabled".

Use function code "10h" (Preset Multiple Registers) when setting. The setting is shown as follows:

Bit	Description
0	Turn off the simultaneous start signal.
1	Turn on the simultaneous start signal.

Simultaneous start is executed by setting "1" to this register.

When the operation is complete, change the point table No. or the program No. after setting "0" to this register. Simultaneous start will be executed again by setting "1" to this register.

5.8.5 Controller force stop (2D9Bh)

Address	Name	Data type	Read/write	No. of points/ No. of registers	Continuous read/ continuous write
2D9Bh	C_EM1/2 command	1 byte	Writing	1	Impossible

Controller operations can be forcibly stopped using the function code "10h" (Preset Multiple Registers).

The following table lists the setting values of this register.

Bit	Description
0	Controller force stop OFF
1	Controller force stop ON

Controller force stop is performed without reference to the broadcast setting (2D98h).

Use this register to forcibly stop the servo amplifiers of all axes in the broadcast communication.

5. DRIVING MOTOR

5.8.6 Override (2DB0h)

Address	Name	Data type	Read/write	No. of points/ No. of registers	Continuous read/ continuous write
2DB0h	Override	2 bytes	Read/write	1	Impossible

Turning on OVR (override selection) enables the setting.

The override value can be read using the function code "03h" (Read Holding Registers).

An override value can be set using the function code "10h" (Preset Multiple Registers).

Set the override value between 0% and 200% in the unit of %.

5.8.7 Forward torque limit value (60E0h)

Address	Name	Data type	Read/write	No. of points/ No. of registers	Continuous read/ continuous write
60E0h	Positive torque limit value	2 bytes	Read/write	1	Impossible

The forward torque limit value can be read using the function code "03h" (Read Holding Registers).

A forward torque limit value can be set using the function code "10h" (Preset Multiple Registers).

Set a forward torque limit value in units of 0.1%.

5.8.8 Reverse torque limit value (60E1h)

Address	Name	Data type	Read/write	No. of points/ No. of registers	Continuous read/ continuous write
60E1h	Negative torque limit value	2 bytes	Read/write	1	Impossible

The reverse torque limit value can be read using the function code "03h" (Read Holding Registers).

A reverse torque limit value can be set using the function code "10h" (Preset Multiple Registers).

Set a reverse torque limit value in units of 0.1%.

5.8.9 Current position (6064h)

Address	Name	Data type	Read/write	No. of points/ No. of registers	Continuous read/ continuous write
6064h	Position actual value	4 bytes	Read	2	Impossible

The current position can be read using the function code "03h" (Read Holding Registers). The read value is the same as the one in the address 2B2Fh for monitoring (refer to section 4.2).

5.8.10 Current speed (606Ch)

Address	Name	Data type	Read/write	No. of points/ No. of registers	Continuous read/ continuous write
606Ch	Velocity actual value	4 bytes	Read	2	Impossible

The current speed can be read using the function code "03h" (Read Holding Registers).

The read data is in the unit of r/min.

5. DRIVING MOTOR

5.8.11 Current torque (6077h)

Address	Name	Data type	Read/write	No. of points/ No. of registers	Continuous read/ continuous write
6077h	Torque actual value	2 bytes	Read	1	Impossible

The current torque value can be read using function code "03h" (Read Holding Registers). The read data is in the unit of 0.1%.

5.8.12 Cam number setting (2D80h)

Address	Name	Data type	Read/write	No. of points/ No. of registers	Continuous read/ continuous write
2D80h	Target CAM No.	1 byte	Read/write	1	Impossible

A set cam number can be read using the function code "03h" (Read Holding Registers).

A cam number can be set using the function code "10h" (Preset Multiple Registers). If [Cam control data No. 49 - Cam No.] is "0", the cam number setting with "2D80h" is enabled.

If the cam number is not "0", the setting of [Cam control data No. 49] is enabled.

For details of cam control data numbers, refer to "MR-JE-_A Servo Amplifier Instruction Manual (Positioning Mode).

5.8.13 Current cam number (2D82h)

Address	Name	Data type	Read/write	No. of points/ No. of registers	Continuous read/ continuous write
2D82h	CAM actual No.	1 byte	Read	1	Impossible

While a cam control operation is being performed (when "1" is set in bit 5 of 2D12h), the cam number being used in the operation can be read using the function code "03h" (Read Holding Registers).

5.8.14 Cam axis one-cycle length setting (2D84h)

Address	Name	Data type	Read/write	No. of points/ No. of registers	Continuous read/ continuous write
2D84h	One cycle length of CAM axis	4 bytes	Read/write	2	Impossible

The set one-cycle length of a cam axis can be read with the function code "03h" (Read Holding Registers). Reading of the one-cycle length of a cam axis is available with servo amplifiers with software version D0 or later.

The one-cycle length of a cam axis can be written in the RAM space in the servo amplifier using the function code "10h" (Preset Multiple Registers).

5. DRIVING MOTOR

5.8.15 Cam stroke length setting (2D85h)

Address	Name	Data type	Read/write	No. of points/ No. of registers	Continuous read/ continuous write
2D85h	Stroke movement of CAM	4 bytes	Read/write	2	Impossible

The set one-cycle length of a cam axis can be read with the function code "03h" (Read Holding Registers). Reading of the one-cycle length of a cam axis is available with servo amplifiers with software version D0 or later.

A cam stroke length can be written in the RAM space in the servo amplifier using the function code "10h" (Preset Multiple Registers).

5.8.16 Request store CAM (2D88h)

Address	Name	Data type	Read/write	No. of points/ No. of registers	Continuous read/ continuous write
2D88h	Request store CAM	1 bytes	Writing	1	Impossible

Cam data can be written in the RAM space in the servo amplifier using the function code "10h" (Preset Multiple Registers). Always set "0".

5.8.17 CAM area (2D89h)

Address	Name	Data type	Read/write	No. of points/ No. of registers	Continuous read/ continuous write
2D89h	CAM area	2 bytes	Read/write	1	Impossible

The storage area of cam data to be read or written can be set using the function code "10h" (Preset Multiple Registers).

5.8.18 CAM data in CAM area (2D8Bh)

Address	Name	Data type	Read/write	No. of points/ No. of registers	Continuous read/ continuous write
2D8Bh	CAM data in CAM area	64 bytes	Read/write	32	Impossible

Cam data can be read using function code "03h" (Read Holding Registers).

Cam data in the area specified by using the CAM area (2D89h) can be read.

Cam data can be written in the RAM space in the servo amplifier using the function code "10h" (Preset Multiple Registers).

Specify the space in which cam data is written with the CAM area (2D89h).

6. LIST OF MODBUS REGISTERS

6. LIST OF MODBUS REGISTERS

The following shows the data types used for the Modbus registers.

Data type	Abbreviation	Size	Range
Unsigned8	UINT8	1 byte	0 to 31
Unsigned16	UINT16	2 bytes	0 to 65535
Unsigned32	UINT32	4 bytes	0 to 4294967295
Integer8	INT8	1 byte	-128 to 127
Integer16	INT16	2 bytes	-32768 to 32767
Integer32	INT32	4 bytes	-2147483648 to 2147483647
Visible string	VS		

The following shows the list of the Modbus registers supported in the Modbus RTU communication for the MR-JE-_A servo amplifier.

Register No.	Function	Data type	Reference
1000h	Supported profile information	4 bytes (UINT32)	Section 4.27
1001h	Alarm Information	1 byte (UINT8)	Section 4.6
1008h	Servo amplifier model	1 byte × 32 (VS)	Section 4.18
100Ah	Servo amplifier software version	1 byte × 16 (VS)	Section 4.19
1010h	Writing command to EEPROM	1 byte (UINT8)	Section 4.5
		4 bytes (UINT32)	
		4 bytes (UINT32)	
		4 bytes (UINT32)	
		4 bytes (UINT32)	
1018h	Device information	1 byte (UINT8)	Section 4.28
		4 bytes (UINT32)	
		4 bytes (UINT32)	
		4 bytes (UINT32)	
2001h to 2020h	PA01 to PA32	4 bytes (INT32)	Section 4.3
2081h to 20C0h	PB01 to PB64	4 bytes (INT32)	Section 4.3
2101h to 2150h	PC01 to PC80	4 bytes (INT32)	Section 4.3
2181h to 21B0h	PD01 to PD48	4 bytes (INT32)	Section 4.3
2201h to 2240h	PE01 to PE64	4 bytes (INT32)	Section 4.3
2281h to 22B0h	PF01 to PF48	4 bytes (INT32)	Section 4.3
2481h to 24B0h	PT01 to PT48	4 bytes (INT32)	Section 4.3
2801h to 281Fh	Point table setting	1 byte (UINT8)	Section 4.4
		4 bytes (INT32)	
		2 bytes (UINT16)	
		2 bytes (UINT16)	
		2 bytes (UINT16)	
		2 bytes (UINT16)	
		1 byte (UINT8)	
1 byte (UINT8)			
2A00h to 2A0Fh	Alarm history	1 byte (UINT8)	Section 4.9
		4 bytes (UINT32)	
		4 bytes (UINT32)	
2A40h	Alarm history clear	2 bytes (UINT16)	Section 4.10
2A43h	Point table error	1 byte (UINT8)	Section 4.13
		2 bytes (UINT16)	
		4 bytes (UINT32)	
2A44h	Parameter error count	2 bytes (UINT16)	Section 4.11

6. LIST OF MODBUS REGISTERS

Register No.	Function	Data type	Reference
2A45h	Parameter error list	1 byte (UINT8)	Section 4.12
		2 bytes (UINT16) × 32	
2A60h	SDO Abort Code	4 bytes (UINT32)	Section 4.23
2A64h	Access Log 1	4 bytes (UINT32)	Section 4.24
2A65h	Access Log 2	4 bytes (UINT32)	Section 4.25
2A68h	Communication error count	2 bytes (UINT16)	Section 4.26
2B01h	Cumulative feedback pulses	4 bytes (INT32)	Section 4.2
2B02h	Servo motor speed	4 bytes (INT32)	Section 4.2
2B03h	Droop pulses	4 bytes (INT32)	Section 4.2
2B04h	Cumulative command pulses	4 bytes (INT32)	Section 4.2
2B05h	Command pulse frequency	4 bytes (INT32)	Section 4.2
2B06h	Analog speed command voltage	2 bytes (INT16)	Section 4.2
	Analog speed limit voltage		
2B07h	Analog torque limit voltage	2 bytes (INT16)	Section 4.2
	Analog torque command voltage		
2B08h	Regenerative load ratio	2 bytes (UINT16)	Section 4.2
2B09h	Effective load ratio	2 bytes (UINT16)	Section 4.2
2B0Ah	Peak load ratio	2 bytes (UINT16)	Section 4.2
2B0Bh	Instantaneous torque	2 bytes (INT16)	Section 4.2
2B0Ch	Position within one-revolution	4 bytes (INT32)	Section 4.2
2B0Dh	Multi-revolution counter	4 bytes (INT32)	Section 4.2
2B0Eh	Load to motor inertia ratio	2 bytes (UINT16)	Section 4.2
2B0Fh	Bus voltage	2 bytes (UINT16)	Section 4.2
2B25h	Encoder inside temperature	2 bytes (INT16)	Section 4.2
2B26h	Settling time	2 bytes (INT16)	Section 4.2
2B27h	Oscillation detection frequency	2 bytes (INT16)	Section 4.2
2B28h	Number of tough drive operations	2 bytes (UINT16)	Section 4.2
2B2Dh	Unit power consumption	2 bytes (INT16)	Section 4.2
2B2Eh	Unit total power consumption	4 bytes (INT32)	Section 4.2
2B2Fh	Current position	4 bytes (INT32)	Section 4.2
2B30h	Command position	4 bytes (INT32)	Section 4.2
2B31h	Command remaining distance	4 bytes (INT32)	Section 4.2
2B32h	Point table No./Program No.	2 bytes (INT16)	Section 4.2
2B33h	Step No.	2 bytes (INT16)	Section 4.2
2B34h	Analog override voltage	2 bytes (INT16)	Section 4.2
2B35h	Override level	2 bytes (INT16)	Section 4.2
2B38h	Current position in one cycle of CAM axis	4 bytes (INT32)	Section 4.2
2B39h	Basis position of CAM	4 bytes (INT32)	Section 4.2
2B3Ah	Feed current position of CAM	4 bytes (INT32)	Section 4.2
2B3Bh	Executed CAM No.	2 bytes (INT16)	Section 4.2
2B3Ch	Stroke movement of executed CAM	4 bytes (INT32)	Section 4.2
2B3Dh	Current position of main axis	4 bytes (INT32)	Section 4.2
2B3Eh	Current position in one cycle of main axis	4 bytes (INT32)	Section 4.2
2C10h	External input pin status	1 byte (UINT8)	Section 4.14
		4 bytes (UINT32)	
2C11h	External output pin status	1 byte (UINT8)	Section 4.15
		4 bytes (UINT32)	
2C12h	Input device status	1 byte (UINT8)	Section 4.16
		4 bytes (UINT32)	
		4 bytes (UINT32)	
		4 bytes (UINT32)	

6. LIST OF MODBUS REGISTERS

Register No.	Function	Data type	Reference
2C13h	Output device status	1 byte (UINT8)	Section 4.17
		4 bytes (UINT32)	
		4 bytes (UINT32)	
		4 bytes (UINT32)	
2D01h to 2D09h	Control input	2 bytes (UINT16)	Section 5.8.2
2D11h to 2D19h	Control output	2 bytes (UINT16)	Section 5.8.3
2D28h	Servo motor rated speed	4 bytes (UINT32)	Section 4.21
2D29h	Servo motor maximum speed	4 bytes (UINT32)	Section 4.22
2D60h	Point table specification	2 bytes (INT16)	Section 5.5
2D68h	Point table request	2 bytes (INT16)	Section 5.5
2D69h	Current point table	2 bytes (INT16)	Section 5.5
2D70h	Program number specification	2 bytes (INT16)	Section 5.6
2D78h	Program number request	2 bytes (INT16)	Section 5.6
2D79h	Program step number	2 bytes (INT16)	Section 5.6
2D80h	Cam number setting	1 byte (UINT8)	Section 5.8.12
2D82h	Current cam number	1 byte (UINT8)	Section 5.8.13
2D84h	Cam axis one cycle length setting	4 bytes (INT32)	Section 5.8.14
2D85h	Cam stroke length setting	4 bytes (INT32)	Section 5.8.15
2D88h	Request store CAM	1 byte (UINT8)	Section 5.8.16
2D89h	CAM area	2 bytes (UINT16)	Section 5.8.17
2D8Bh	CAM data in CAM area	64 bytes	Section 5.8.18
2D98h	Broadcast Setting	1 byte (UINT8)	Section 4.20
2D9Ah	Simultaneous start bit setting	1 byte (UINT8)	Section 5.8.4
2D9Bh	Controller force stop	1 byte (UINT8)	Section 5.8.5
2DB0h	Override	2 bytes (UINT16)	Section 5.8.6
6040h	Control command	2 bytes (UINT16)	Section 5.1
6041h	Control status	2 bytes (UINT16)	Section 5.1
6060h	Control mode	1 byte (INT8)	Section 5.2
6061h	Control mode display	1 byte (INT8)	Section 5.2
6064h	Current position	4 bytes (UINT32)	Section 5.8.9
606Ch	Current speed	4 bytes (UINT32)	Section 5.8.10
6077h	Current torque	2 bytes (UINT16)	Section 5.8.11
607Dh	Software limit	1 byte (UINT8)	Section 5.4
		4 bytes (UINT32)	
		4 bytes (UINT32)	
6081h	Command speed	4 bytes (UINT32)	Section 5.4
6083h	Acceleration time constant	4 bytes (UINT32)	Section 5.4
6084h	Deceleration time constant	4 bytes (UINT32)	Section 5.4
6098h	Home position return method	1 byte (INT8)	Section 5.3
6099h	Home position return speed	1 byte (UINT8)	Section 5.3
		4 bytes (UINT32)	
		4 bytes (UINT32)	
60B8h	Touch probe function setting	2 bytes (UINT16)	Section 5.7
60B9h	Touch probe function status	2 bytes (UINT16)	Section 5.7
60BAh	Rising edge position of touch probe	2 bytes (UINT16)	Section 5.7
60BBh	Falling edge position of touch probe	2 bytes (UINT16)	Section 5.7
60E0h	Forward torque limit value	2 bytes (UINT16)	Section 5.8.7
60E1h	Reverse torque limit value	2 bytes (UINT16)	Section 5.8.8
6502h	Supported control mode	4 bytes (UINT32)	Section 5.2

7. APPLICATION OF FUNCTIONS

7. APPLICATION OF FUNCTIONS

This chapter explains application of using servo amplifier functions.

7.1 Connection with GOT2000 series

POINT
<ul style="list-style-type: none">● For the details of the device data transfer, refer to section 9.4 of "GT Designer3 (GOT2000) Screen Design Manual".● For the details of conversion of Modbus register addresses, refer to chapter 5 of "GOT2000 Series Connection Manual (Microcomputers, MODBUS/Fieldbus Products, Peripherals)".

7.1.1 Access to Modbus registers

(1) Reading data from Modbus registers

When reading data from a 4-byte Modbus register or a Modbus register containing multiple elements, use the device data transfer function to store the data in GOT data register (GD). Converting the data type of a GD device enables to read data from a 4-byte Modbus register or a Modbus register containing multiple elements.

(a) Transferring device data to GOT data registers (GD)

POINT
<ul style="list-style-type: none">● When reading/writing data from/to a Modbus register with one GD, use different device data transfer IDs for reading and writing.

Set the following items 1) to 3) in the device data transfer window.

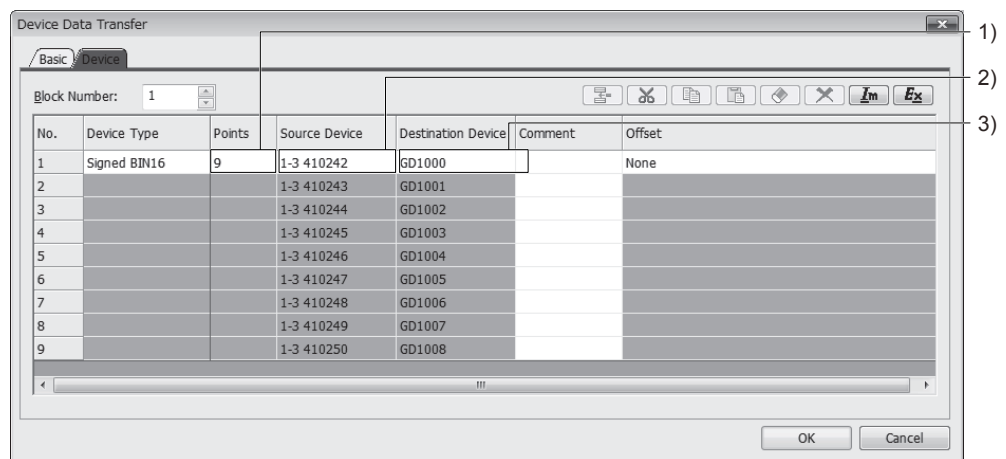

7. APPLICATION OF FUNCTIONS

1) Points

Set the number of Modbus registers (No. of Points).

2) Source device

Set a servo amplifier station number and a Modbus register address. The address must be converted into the device number readable on GT Designer3 before setting.

Example of converting a Modbus register address into a device number readable on GT Designer3:

Reading the data of Modbus register address "2801h"

a) Convert the Modbus register address into decimal. Modbus register address "2801h" is equal to "10241" in decimal.

b) Use the following equation to convert the Modbus register address into the device number readable on GT Designer3.

Device number on GT Designer3 = 400000 + Modbus register address in decimal + 1

Based on a) and b) above, for "2801h", the device number on GT Designer3 is calculated as follows: $400000 + 10241 + 1 = 410242$

3) Destination device

Set a GOT data register (GD) for storing the data of a Modbus register.

(b) Setting the data type of a GD device

Set the data type of a GD device. For a 1-byte or 2-byte Modbus register, set 16-bit data type. For a 4-byte Modbus register, set 32-bit data type. For a Modbus register containing multiple elements, set the data type according to the elements.

7. APPLICATION OF FUNCTIONS

(2) Writing data to Modbus registers

POINT
<ul style="list-style-type: none"> ● When reading/writing data from/to a Modbus register with one GOT data register (GD), use different device data transfer IDs for reading and writing. ● When writing data to a 4-byte Modbus register or a Modbus register containing multiple elements, store the data in consecutive GD devices.

When writing data to a 4-byte Modbus register or a Modbus register containing multiple elements, use the device data transfer function to store the data of a GD device in the Modbus register.

Set the following items 1) to 3) in the device data transfer window.

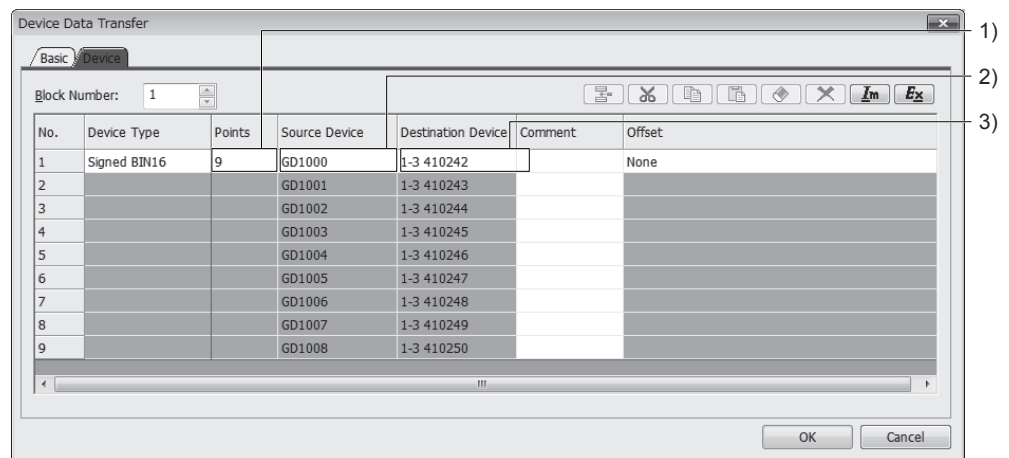

1) Points

Set the number of Modbus registers (No. of Registers).

2) Source device

Set a GOT data register (GD) in which the data of a Modbus register is stored.

3) Destination device

Set a servo amplifier station number and a Modbus register address. The address must be converted into the device number readable on GT Designer3 before setting. For how to convert Modbus register addresses, refer to section 7.1.1 (1) (a) 2).

7. APPLICATION OF FUNCTIONS

MEMO

REVISIONS

*The manual number is given on the bottom left of the back cover.

Revision Date	*Manual Number	Revision
Jun. 2015	SH(NA)030177ENG-A	First edition
Aug. 2016	SH(NA)030177ENG-B	<p>The simple cam function is supported, and chapter 7 is added.</p> <p>3. To prevent injury, note the following</p> <p>4. Additional instructions</p> <p>(2) Wiring Partially added.</p> <p>(5) Corrective actions Partially added.</p> <p>(6) Maintenance, inspection and parts replacement Partially added and partially changed.</p> <p>Section 1.1 Partially changed.</p> <p>Section 2.1 Partially added and partially changed.</p> <p>Section 3.4.2 Partially changed.</p> <p>Section 3.4.4 Partially changed.</p> <p>Section 3.4.5 Partially changed.</p> <p>Section 4.3.1 Partially changed.</p> <p>Section 4.16.2 The table is changed.</p> <p>Section 4.17.2 The table is changed.</p> <p>Section 4.23.2 Partially added.</p> <p>Section 4.28.2 Partially changed.</p> <p>Section 5.1.1 Partially changed.</p> <p>Section 5.1.3 Partially changed.</p> <p>Section 5.3.3 Partially changed.</p> <p>Section 5.4.1 Partially changed.</p> <p>Section 5.4.2 Partially changed.</p> <p>Section 5.4.3 (1) Partially changed.</p> <p>Section 5.4.3 (7) Newly added.</p> <p>Section 5.4.4 Partially added and partially changed.</p> <p>Section 5.5.2 Partially changed.</p> <p>Section 5.5.3 Partially changed.</p> <p>Section 5.6.2 Partially changed.</p> <p>Section 5.6.3 Partially changed.</p> <p>Section 5.7.3 (2) Partially changed.</p> <p>Section 5.7.4 Partially changed.</p> <p>Section 5.8.1 Partially added.</p> <p>Section 5.8.4 (2) Partially changed.</p> <p>Section 5.8.12 Partially changed.</p> <p>Section 5.8.13 Partially changed.</p> <p>Section 5.8.16 Newly added.</p> <p>Section 5.8.17 Newly added.</p> <p>Section 5.8.18 Newly added.</p> <p>Chapter 6 Partially added and partially changed.</p> <p>Chapter 7 Newly added.</p>
Aug. 2017	SH(NA)030177ENG-C	<p>A maximum altitude of 2000 m above sea level is supported.</p> <p>3. To prevent injury, note the following</p> <p>4. Additional instructions Partially changed.</p> <p>Section 1.1 Partially changed.</p> <p>Section 1.2 Partially changed.</p> <p>Section 1.3 Partially changed.</p> <p>Chapter 2 CAUTION is partially changed.</p> <p>Section 2.1 Partially changed.</p> <p>Section 2.2 Partially changed.</p> <p>Section 3.1 Partially changed.</p> <p>Section 3.2 Partially changed.</p>

Revision Date	*Manual Number	Revision	
Aug. 2017	SH(NA)030177ENG-C	Section 3.3 Section 3.4.2 Section 3.4.5 Chapter 4 Section 4.1 Section 4.20 Section 4.21 Section 4.24.1 Section 4.25.2 Section 4.26 Chapter 5 Section 5.1.3 Section 5.3 Section 5.4 Section 5.5.4 Section 5.6.4 Section 5.8.1 Section 5.8.14 Section 5.8.15 Chapter 6	Partially changed. Partially changed. Partially changed. CAUTION is partially changed. Partially changed. Partially changed. Partially changed. Partially changed. Partially changed. Partially changed. POINT is partially changed. Partially changed. Partially changed. Partially changed. Partially changed. Partially changed. Partially changed. Partially changed. Partially changed. Partially changed. Partially changed.

This manual confers no industrial property rights or any rights of any other kind, nor does it confer any patent licenses. Mitsubishi Electric Corporation cannot be held responsible for any problems involving industrial property rights which may occur as a result of using the contents noted in this manual.

MELSERVO is a trademark or registered trademark of Mitsubishi Electric Corporation in Japan and/or other countries.
All other product names and company names are trademarks or registered trademarks of their respective companies.

Warranty

1. Warranty period and coverage

We will repair any failure or defect hereinafter referred to as "failure" in our FA equipment hereinafter referred to as the "Product" arisen during warranty period at no charge due to causes for which we are responsible through the distributor from which you purchased the Product or our service provider. However, we will charge the actual cost of dispatching our engineer for an on-site repair work on request by customer in Japan or overseas countries. We are not responsible for any on-site readjustment and/or trial run that may be required after a defective unit are repaired or replaced.

[Term]

The term of warranty for Product is twelve (12) months after your purchase or delivery of the Product to a place designated by you or eighteen (18) months from the date of manufacture whichever comes first ("Warranty Period"). Warranty period for repaired Product cannot exceed beyond the original warranty period before any repair work.

[Limitations]

- (1) You are requested to conduct an initial failure diagnosis by yourself, as a general rule.
It can also be carried out by us or our service company upon your request and the actual cost will be charged. However, it will not be charged if we are responsible for the cause of the failure.
- (2) This limited warranty applies only when the condition, method, environment, etc. of use are in compliance with the terms and conditions and instructions that are set forth in the instruction manual and user manual for the Product and the caution label affixed to the Product.
- (3) Even during the term of warranty, the repair cost will be charged on you in the following cases;
 - (i) a failure caused by your improper storing or handling, carelessness or negligence, etc., and a failure caused by your hardware or software problem
 - (ii) a failure caused by any alteration, etc. to the Product made on your side without our approval
 - (iii) a failure which may be regarded as avoidable, if your equipment in which the Product is incorporated is equipped with a safety device required by applicable laws and has any function or structure considered to be indispensable according to a common sense in the industry
 - (iv) a failure which may be regarded as avoidable if consumable parts designated in the instruction manual, etc. are duly maintained and replaced
 - (v) any replacement of consumable parts (battery, fan, smoothing capacitor, etc.)
 - (vi) a failure caused by external factors such as inevitable accidents, including without limitation fire and abnormal fluctuation of voltage, and acts of God, including without limitation earthquake, lightning and natural disasters
 - (vii) a failure generated by an unforeseeable cause with a scientific technology that was not available at the time of the shipment of the Product from our company
 - (viii) any other failures which we are not responsible for or which you acknowledge we are not responsible for

2. Term of warranty after the stop of production

- (1) We may accept the repair at charge for another seven (7) years after the production of the product is discontinued. The announcement of the stop of production for each model can be seen in our Sales and Service, etc.
- (2) Please note that the Product (including its spare parts) cannot be ordered after its stop of production.

3. Service in overseas countries

Our regional FA Center in overseas countries will accept the repair work of the Product. However, the terms and conditions of the repair work may differ depending on each FA Center. Please ask your local FA center for details.

4. Exclusion of loss in opportunity and secondary loss from warranty liability

Regardless of the gratis warranty term, Mitsubishi shall not be liable for compensation to:

- (1) Damages caused by any cause found not to be the responsibility of Mitsubishi.
- (2) Loss in opportunity, lost profits incurred to the user by Failures of Mitsubishi products.
- (3) Special damages and secondary damages whether foreseeable or not, compensation for accidents, and compensation for damages to products other than Mitsubishi products.
- (4) Replacement by the user, maintenance of on-site equipment, start-up test run and other tasks.

5. Change of Product specifications

Specifications listed in our catalogs, manuals or technical documents may be changed without notice.

6. Application and use of the Product

- (1) For the use of our General-Purpose AC Servo, its applications should be those that may not result in a serious damage even if any failure or malfunction occurs in General-Purpose AC Servo, and a backup or fail-safe function should operate on an external system to General-Purpose AC Servo when any failure or malfunction occurs.
- (2) Our General-Purpose AC Servo is designed and manufactured as a general purpose product for use at general industries. Therefore, applications substantially influential on the public interest for such as atomic power plants and other power plants of electric power companies, and also which require a special quality assurance system, including applications for railway companies and government or public offices are not recommended, and we assume no responsibility for any failure caused by these applications when used
In addition, applications which may be substantially influential to human lives or properties for such as airlines, medical treatments, railway service, incineration and fuel systems, man-operated material handling equipment, entertainment machines, safety machines, etc. are not recommended, and we assume no responsibility for any failure caused by these applications when used. We will review the acceptability of the abovementioned applications, if you agree not to require a specific quality for a specific application. Please contact us for consultation.

MODEL	MR-JE-A INSTRUCTIONMANUAL(MODBUS-RTU)
MODEL CODE	1CW708

mitsubishi electric corporation

HEAD OFFICE: TOKYO BLDG MARUNOUCHI TOKYO 100-8310