



General-Purpose AC Servo

MELSERVO-J3 Series

SSCNET III Fully Closed Loop Control

MODEL

MR-J3-□B-RJ006

SERVO AMPLIFIER

INSTRUCTION MANUAL

● Safety Instructions ●

(Always read these instructions before using the equipment.)

Do not attempt to install, operate, maintain or inspect the servo amplifier and servo motor until you have read through this Instruction Manual, Installation guide, Servo motor Instruction Manual (Vol.2) and appended documents carefully and can use the equipment correctly. Do not use the servo amplifier and servo motor until you have a full knowledge of the equipment, safety information and instructions.

In this Instruction Manual, the safety instruction levels are classified into "WARNING" and "CAUTION".





Indicates that incorrect handling may cause hazardous conditions, resulting in death or severe injury.





Indicates that incorrect handling may cause hazardous conditions, resulting in medium or slight injury to personnel or may cause physical damage.

Note that the CAUTION level may lead to a serious consequence according to conditions. Please follow the instructions of both levels because they are important to personnel safety.

What must not be done and what must be done are indicated by the following diagrammatic symbols.

: Indicates what must not be done. For example, "No Fire" is indicated by .

: Indicates what must be done. For example, grounding is indicated by .

In this Instruction Manual, instructions at a lower level than the above, instructions for other functions, and so on are classified into "POINT".

After reading this installation guide, always keep it accessible to the operator.

1. To prevent electric shock, note the following

 **WARNING**

- Before wiring or inspection, turn off the power and wait for 15 minutes or more until the charge lamp turns off. Then, confirm that the voltage between P(+) and N(—) is safe with a voltage tester and others. Otherwise, an electric shock may occur. In addition, always confirm from the front of the servo amplifier, whether the charge lamp is off or not.
- Connect the servo amplifier and servo motor to ground.
- Any person who is involved in wiring and inspection should be fully competent to do the work.
- Do not attempt to wire the servo amplifier and servo motor until they have been installed. Otherwise, you may get an electric shock.
- Operate the switches with dry hand to prevent an electric shock.
- The cables should not be damaged, stressed, loaded, or pinched. Otherwise, you may get an electric shock.
- During power-on or operation, do not open the front cover of the servo amplifier. You may get an electric shock.
- Do not operate the servo amplifier with the front cover removed. High-voltage terminals and charging area are exposed and you may get an electric shock.
- Except for wiring or periodic inspection, do not remove the front cover even of the servo amplifier if the power is off. The servo amplifier is charged and you may get an electric shock.

2. To prevent fire, note the following

 **CAUTION**

- Install the servo amplifier, servo motor and regenerative resistor on incombustible material. Installing them directly or close to combustibles will lead to a fire.
- Always connect a magnetic contactor between the main circuit power supply and L1, L2, and L3 of the servo amplifier, and configure the wiring to be able to shut down the power supply on the side of the servo amplifier's power supply. If a magnetic contactor is not connected, continuous flow of a large current may cause a fire when the servo amplifier malfunctions.
- When a regenerative resistor is used, use an alarm signal to switch main power off. Otherwise, a regenerative transistor fault or the like may overheat the regenerative resistor, causing a fire.
- Provide adequate protection to prevent screws and other conductive matter, oil and other combustible matter from entering the servo amplifier and servo motor.
- Always connect a no-fuse breaker to the power supply of the servo amplifier.

3. To prevent injury, note the follow

CAUTION

- Only the voltage specified in the Instruction Manual should be applied to each terminal, Otherwise, a burst, damage, etc. may occur.
- Connect the terminals correctly to prevent a burst, damage, etc.
- Ensure that polarity (+, -) is correct. Otherwise, a burst, damage, etc. may occur.
- Take safety measures, e.g. provide covers, to prevent accidental contact of hands and parts (cables, etc.) with the servo amplifier heat sink, regenerative resistor, servo motor, etc. since they may be hot while power is on or for some time after power-off. Their temperatures may be high and you may get burnt or a parts may damaged.
- During operation, never touch the rotating parts of the servo motor. Doing so can cause injury.

4. Additional instructions

The following instructions should also be fully noted. Incorrect handling may cause a fault, injury, electric shock, etc.

(1) Transportation and installation

CAUTION

- Transport the products correctly according to their mass.
- Stacking in excess of the specified number of products is not allowed.
- Do not carry the servo motor by the cables, shaft or encoder.
- Do not hold the front cover to transport the servo amplifier. The servo amplifier may drop.
- Install the servo amplifier in a load-bearing place in accordance with the Instruction Manual.
- Do not climb or stand on servo equipment. Do not put heavy objects on equipment.
- The servo amplifier and servo motor must be installed in the specified direction.
- Leave specified clearances between the servo amplifier and control enclosure walls or other equipment.
- Do not install or operate the servo amplifier and servo motor which has been damaged or has any parts missing.
- Do not block intake and exhaust areas of the servo amplifier and servo motor which has a cooling fan. Doing so may cause faults.
- Do not drop or strike servo amplifier or servo motor. Isolate from all impact loads.
- Securely attach the servo motor to the machine. If attach insecurely, the servo motor may come off during operation.
- The servo motor with a reduction gear must be installed in the specified direction to prevent oil leakage.
- Take safety measures, e.g. provide covers, to prevent accidental access to the rotating parts of the servo motor during operation.
- Never hit the servo motor or shaft, especially when coupling the servo motor to the machine. The encoder may become faulty.
- Do not subject the servo motor shaft to more than the permissible load. Otherwise, the shaft may break.
- When the equipment has been stored for an extended period of time, consult Mitsubishi.

⚠ CAUTION

- When you keep or use it, please fulfill the following environmental conditions.

Environment			Conditions	
			Servo amplifier	Servo motor
Ambient temperature	In operation	[°C]	0 to 55 (non-freezing)	0 to 40 (non-freezing)
		[°F]	32 to 131 (non-freezing)	32 to 104 (non-freezing)
	In storage	[°C]	-20 to 65 (non-freezing)	-15 to 70 (non-freezing)
		[°F]	-4 to 149 (non-freezing)	5 to 158 (non-freezing)
Ambient humidity	In operation	90%RH or less (non-condensing)		80%RH or less (non-condensing)
	In storage	90%RH or less (non-condensing)		
Ambience			Indoors (no direct sunlight) Free from corrosive gas, flammable gas, oil mist, dust and dirt	
Altitude			Max. 1000m above sea level	
(Note) Vibration		5.9 m/s ² or less at 10 to 55Hz (directions of X, Y and Z axes)	HF-MP series HF-KP series	X, Y: 49 m/s ²
			HF-SP51 • 81 HF-SP52 to 152 HF-SP524 to 1524 HC-RP Series HC-UP72 • 152	X, Y: 24.5 m/s ²
			HF-SP121 • 201 HF-SP202 • 352 HF-SP2024 • 3524 HC-UP202 to 502	X: 24.5 m/s ² Y: 49 m/s ²
			HF-SP301 • 421 HF-SP502 • 702 HF-SP5024 • 7024	X: 24.5 m/s ² Y: 29.4 m/s ²
			HC-LP52 to 152	X: 9.8 m/s ² Y: 24.5 m/s ²
			HC-LP202 to 302	X: 19.6 m/s ² Y: 49 m/s ²
			HA-LP601 to 12K1 HA-LP701M to 15K1M HA-LP502 to 22K2 HA-LP6014 • 12K14 HA-LP701M4 • 15K1M4 HA-LP11K24 to 22K24	X: 11.7 m/s ² Y: 29.4 m/s ²
			HA-LP15K1 to 25K1 HA-LP22K1M HA-LP15K14 • 20K14 HA-LP22K1M4	X, Y: 9.8 m/s ²

Note. Except the servo motor with a reduction gear.

- When treating the servo amplifier be careful about the edged parts such as the corners of the servo amplifier.
- The servo amplifier must install in the metal cabinet (control box).

(2) Wiring

⚠ CAUTION

- Wire the equipment correctly and securely. Otherwise, the servo motor may operate unexpectedly.
- Do not install a power capacitor, surge absorber or radio noise filter (FR-BIF-(H) option) between the servo motor and servo amplifier.
- Connect the wires to the correct phase terminals (U, V, W) of the servo amplifier and servo motor. Not doing so may cause unexpected operation.

⚠ CAUTION

- Connect the servo motor power terminal (U, V, W) to the servo motor power input terminal (U, V, W) directly. Do not let a magnetic contactor, etc. intervene.

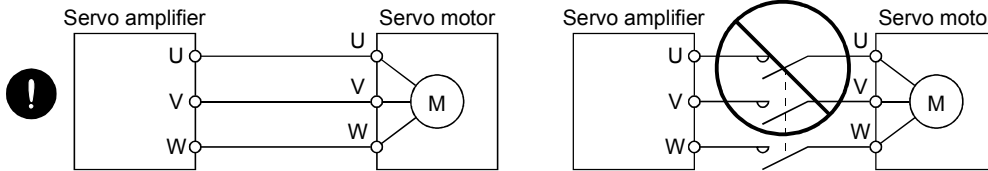

- Do not connect AC power directly to the servo motor. Otherwise, a fault may occur.
- The surge absorbing diode installed on the DC output signal relay of the servo amplifier must be wired in the specified direction. Otherwise, the emergency stop and other protective circuits may not operate.

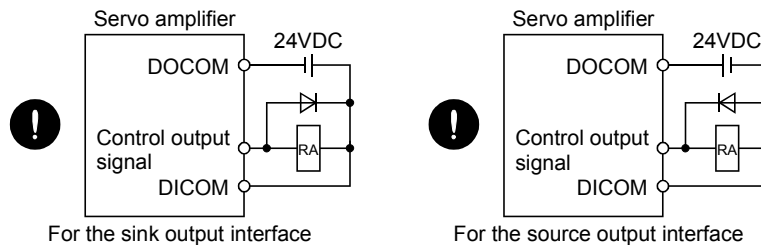

- When the cable is not tightened enough to the terminal block (connector), the cable or terminal block (connector) may generate heat because of the poor contact. Be sure to tighten the cable with specified torque.

(3) Test run adjustment

⚠ CAUTION

- Before operation, check the parameter settings. Improper settings may cause some machines to perform unexpected operation.
- The parameter settings must not be changed excessively. Operation will be insatiable.

(4) Usage

⚠ CAUTION

- Provide an external emergency stop circuit to ensure that operation can be stopped and power switched off immediately.
- Any person who is involved in disassembly and repair should be fully competent to do the work.
- Before resetting an alarm, make sure that the run signal of the servo amplifier is off to prevent an accident. A sudden restart is made if an alarm is reset with the run signal on.
- Do not modify the equipment.
- Use a noise filter, etc. to minimize the influence of electromagnetic interference, which may be caused by electronic equipment used near the servo amplifier.
- Burning or breaking a servo amplifier may cause a toxic gas. Do not burn or break a servo amplifier.

⚠ CAUTION

- Use the servo amplifier with the specified servo motor.
- The electromagnetic brake on the servo motor is designed to hold the motor shaft and should not be used for ordinary braking.
- For such reasons as service life and mechanical structure (e.g. where a ball screw and the servo motor are coupled via a timing belt), the electromagnetic brake may not hold the motor shaft. To ensure safety, install a stopper on the machine side.

(5) Corrective actions

⚠ CAUTION

- When it is assumed that a hazardous condition may take place at the occur due to a power failure or a product fault, use a servo motor with an electromagnetic brake or an external brake mechanism for the purpose of prevention.
- Configure a circuit so that the electromagnetic brake activates with the external emergency stop at the same time.

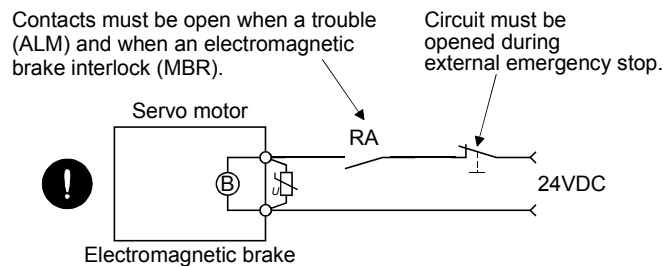

- When any alarm has occurred, eliminate its cause, ensure safety, and deactivate the alarm before restarting operation.
- When power is restored after an instantaneous power failure, keep away from the machine because the machine may be restarted suddenly (design the machine so that it is secured against hazard if restarted).

(6) Maintenance, inspection and parts replacement

⚠ CAUTION

- With age, the electrolytic capacitor of the servo amplifier will deteriorate. To prevent a secondary accident due to a fault, it is recommended to replace the electrolytic capacitor every 10 years when used in general environment.
- Please consult our sales representative.

(7) General instruction

- To illustrate details, the equipment in the diagrams of this Specifications and Instruction Manual may have been drawn without covers and safety guards. When the equipment is operated, the covers and safety guards must be installed as specified. Operation must be performed in accordance with this Specifications and Instruction Manual.

● About processing of waste ●

When you discard servo amplifier, a battery (primary battery), and other option articles, please follow the law of each country (area).

EEP-ROM life

The number of write times to the EEP-ROM, which stores parameter settings, etc., is limited to 100,000. If the total number of the following operations exceeds 100,000, the servo amplifier may fail when the EEP-ROM reaches the end of its useful life.

- Write to the EEP-ROM due to parameter setting changes
- Write to the EEP-ROM due to device changes

Precautions for Choosing the Products

Mitsubishi will not be held liable for damage caused by factors found not to be the cause of Mitsubishi; machine damage or lost profits caused by faults in the Mitsubishi products; damage, secondary damage, accident compensation caused by special factors unpredictable by Mitsubishi; damages to products other than Mitsubishi products; and to other duties.

COMPLIANCE WITH THE EUROPEAN EC DIRECTIVES

Refer to Appendix 5 for the compliance with EC Directives.

COMPLIANCE WITH UL/C-UL STANDARD

Refer to Appendix 6 for the compliance with UL/C-UL standard.

<<About the manuals>>

This Instruction Manual and the following Servo Amplifier/Servo Motor Instruction Manuals (Vol.2) are required if you use the General-Purpose AC servo MR-J3-□B for the first time. Always purchase them and use the MR-J3-□B safely.

Relevant manuals

Manual name	Manual No.
MELSERVO-J3 Series MR-J3-□B Servo Amplifier Instruction Manual	SH(NA)030051
MELSERVO-J3 Series Instructions and Cautions for Safe Use of AC Servos	IB(NA)0300077
MELSERVO Servo Motor Instruction Manual (Vol.2)	SH(NA)030041
EMC Installation Guidelines	IB(NA)67310

This Instruction Manual describes the functions unique to the fully closed loop control compatible servo amplifier MR-J3-□B-RJ006. Therefore, when using the MR-J3-□B-RJ006, refer to the SSCNET III Compatible MR-J3-□B Servo Amplifier Instruction Manual as well. However, the following items are not described in this Instruction Manual. For details of these items, refer to the MR-J3-□B Servo Amplifier Instruction Manual.

Item	MR-J3-□B Servo Amplifier Instruction Manual
INSTALLATION	CHAPTER 2
STARTUP	CHAPTER 4
GENERAL GAIN ADJUSTMENT	CHAPTER 6
SPECIAL ADJUSTMENT FUNCTIONS	CHAPTER 7
CHARACTERISTICS	CHAPTER 10
OPTIONS AND AUXILIARY EQUIPMENT	CHAPTER 11

<<About the wires used for wiring>>

Wiring wires mentioned in this instruction manual are selected based on the ambient temperature of 40°C (104°F).

CONTENTS

1. FUNCTIONS AND CONFIGURATION	1 - 1 to 1 -28
1.1 Overview.....	1 - 1
1.2 Control block diagram	1 - 2
1.3 Servo amplifier standard specifications.....	1 - 3
1.4 Function list	1 - 5
1.5 Selecting procedure of control mode.....	1 - 6
1.5.1 Control mode configuration.....	1 - 6
1.5.2 Dual feedback filter equivalent block diagram.....	1 - 6
1.6 Model code definition	1 - 7
1.7 Combination with servo motor	1 - 8
1.8 Structure	1 - 9
1.8.1 Parts identification	1 - 9
1.8.2 Removal and reinstallation of the front cover	1 -16
1.9 Configuration including auxiliary equipment	1 -19
1.10 System configuration	1 -27
2. SIGNALS AND WIRING	2 - 1 to 2 -18
2.1 Precautions for this chapter	2 - 2
2.2 Input power supply circuit	2 - 2
2.3 I/O signal connection example	2 -14
2.4 Connector and signal arrangements	2 -16
2.5 Internal connection diagram	2 -17
2.6 Treatment of cable shield external conductor	2 -18
3. LOAD SIDE ENCODER	3 - 1 to 3 -20
3.1 Compatible linear encoder list	3 - 1
3.2 Mitsubishi serial interface compatible linear encoder	3 - 2
3.2.1 Linear scales manufactured by Mitutoyo Corporation (absolute type).....	3 - 2
3.2.2 Linear encoder manufactured by Heidenhain Corporation.....	3 - 7
3.2.3 Linear encoder manufactured by Sony Manufacturing Systems Corporation (Incremental type).....	3 -10
3.2.4 Linear encoder manufactured by Renishaw Inc. (Incremental type).....	3 -12
3.3 ABZ-phase differential output load side encoder	3 -14
3.4 Mitsubishi optional cable * connector sets	3 -17
3.4.1 MR-EKCBL□M-H	3 -17
3.4.2 MR-ECNM	3 -19
3.4.3 MR-J3CN2.....	3 -19
4. OPERATION AND FUNCTIONS	4 - 1 to 4 -22
4.1 Startup	4 - 1
4.1.1 Startup procedure.....	4 - 1
4.1.2 Selection of fully closed loop system.....	4 - 2
4.1.3 Selection of load side encoder communication system.....	4 - 3
4.1.4 Setting of load side encoder polarity	4 - 3

4.1.5 Setting of feedback pulse electronic gear	4 - 4
4.1.6 Confirmation of load side encoder position data	4 - 6
4.1.7 Setting of fully closed loop dual feedback filter	4 - 7
4.2 Home position return operation	4 - 8
4.2.1 General precautions	4 - 8
4.2.2 Load side encoder types and home position return methods.....	4 - 8
4.3 Operation from controller	4 - 12
4.3.1 Operation from controller	4 - 12
4.3.2 Servo system controller setting.....	4 - 12
4.4 Functions	4 - 14
4.4.1 Fully closed loop control error detection.....	4 - 14
4.4.2 Auto tuning function	4 - 15
4.4.3 Machine analyzer function	4 - 15
4.4.4 Test operation mode	4 - 16
4.5 Absolute position detection system under fully closed loop system	4 - 16
4.6 About MR Configurator	4 - 17

5. PARAMETERS	5 - 1 to 5 - 20
----------------------	------------------------

5.1 Basic setting parameters (No.PA□□).....	5 - 1
5.1.1 Parameter list	5 - 2
5.1.2 Parameter write inhibit	5 - 3
5.1.3 Selecting a control mode	5 - 4
5.1.4 Using absolute position detection system	5 - 4
5.1.5 In-position range.....	5 - 5
5.1.6 Encoder output pulse	5 - 5
5.2 Gain/filter parameters (No.PB□□).....	5 - 7
5.3 Extension setting parameters (No.PC□□)	5 - 9
5.3.1 Parameter list	5 - 9
5.3.2 List of details.....	5 - 10
5.3.3 Analog monitor	5 - 13
5.4 I/O setting parameters (No.PD□□)	5 - 16
5.4.1 Parameter list	5 - 16
5.5 Extension control parameters (No.PE□□)	5 - 17
5.5.1 Parameter list	5 - 17
5.5.2 List of details.....	5 - 18

6. TROUBLESHOOTING	6 - 1 to 6 - 6
---------------------------	-----------------------

6.1 Alarms and warning list.....	6 - 1
6.2 Remedies for alarms	6 - 2
6.3 Detailed explanation of linear encoder error 1 (2A).....	6 - 5

7. OUTLINE DRAWINGS	7 - 1 to 7 - 10
----------------------------	------------------------

APPENDIX	App.- 1 to App.-16
-----------------	---------------------------

App. 1 Parameter list.....	App.- 1
----------------------------	---------

App. 2 Signal layout recording paper	App.- 2
App. 3 Change of connector sets to the RoHS compatible products.....	App.- 3
App. 4 MR-J3-200B-RJ006 servo amplifiers manufactured before March 2008.....	App.- 4
App. 5 Compliance with the european EC directives.....	App.- 7
App. 6 Compliance with UL/C-UL standard	App.-10

1. FUNCTIONS AND CONFIGURATION

1. FUNCTIONS AND CONFIGURATION

1.1 Overview

This Instruction Manual explains the product that imports a position feedback signal from a load side encoder, such as a linear encoder, to the MR-J3-□B servo amplifier to perform fully closed loop control.

A control mode has the semi closed loop control, dual feedback control and fully closed loop control.

The control modes can be changed by the parameter setting.

For the features of each control mode, refer to section 1.2 in this manual.

[Items changed from those of the standard model (MR-J3-□B)]

- (a) The Mitsubishi serial interface compatible or ABZ-phase pulse train interface compatible linear encoder is used to detect the position feedback signal of the load side encoder.
- (b) In addition to the fully closed loop control that feeds back the position signal of the load side encoder, a dual feedback control that feeds back a signal composed of the load side encoder's position feedback signal and the motor position feedback signal has been added as an extended function.
- (c) Function to switch output pulse between the load side encoder and motor side encoder

[Functions deleted from the standard model (MR-J3-□B)]

- (a) Speed · torque control (For servo amplifiers with Software version B0 or older.)
- (b) Motor-less operation (test operation)

1. FUNCTIONS AND CONFIGURATION

1.2 Control block diagram

A fully closed loop control block diagram is shown below. The fully closed loop system is controlled in the load side encoder unit.

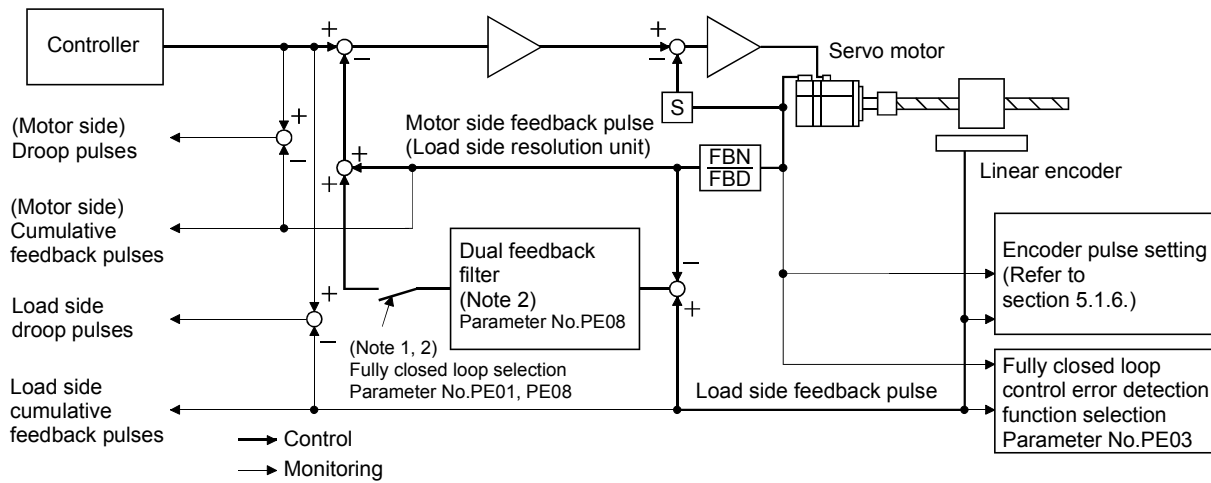

- Note. 1. Switching between semi closed loop control and fully closed loop control can be performed by changing the setting of parameter No. PE01.
 When semi closed loop control is selected, a control is always performed on the bases of the position data of the motor encoder independently of whether the motor is at a stop or running.
2. When parameter No. PE01 "fully closed loop system" is valid, dual feedback control in which the motor feedback signal and load side encoder feedback signal are combined by the dual feedback filter in parameter No. PE08 is performed.
 In this case, fully closed loop control is performed when the motor is at a stop, and semi closed loop control is performed when the motor is operating to improve control performance. When "4500" is set as the filter value of parameter No. PE08, fully closed loop control is always performed.

The following table shows the functions of each control mode.

Control mode	Description	
Semi closed loop control	Feature	Position is controlled according to the motor side data.
	Advantage	Since this control is insusceptible to machine influence (such as machine resonance), the gains of the servo amplifier can be raised and the settling time shortened.
	Disadvantage	If the motor side is at a stop, the side may be vibrating or the load side accuracy not obtained.
Dual feedback control	Feature	Position is controlled according to the motor side data and load side data.
	Advantage	Control is performed according to the motor side data during operation, and according to the load side data at a stop in sequence to raise the gains during operation and shorten the settling time. A stop is made with the load side accuracy.
Fully closed loop control	Feature	Position is controlled according to the load side data.
	Advantage	The load side accuracy is obtained not only at a stop but also during operation.
	Disadvantage	Since this control is susceptible to machine resonance or other influences, the gains of the servo amplifier do not rise and the settling time increases.

1. FUNCTIONS AND CONFIGURATION

1.3 Servo amplifier standard specifications

(1) 200V class, 100V class

Servo amplifier MR-J3-□-RJ006		10B	20B	40B	60B	70B	100B	200B	350B	500B	700B	11KB	15KB	22KB	10B1	20B1	40B1	
output	Rated voltage	3-phase 170VAC																
	Rated current [A]	1.1	1.5	2.8	3.2	5.8	6.0	11.0	17.0	28.0	37.0	68.0	87.0	126.0	1.1	1.5	2.8	
Main circuit power supply	Voltage/frequency	3-phase or 1-phase 200 to 230VAC, 50/60Hz					3-phase 200 to 230VAC, 50/60Hz								1-phase 100V to 120VAC, 50/60Hz			
	Rated current [A]	0.9	1.5	2.6	(Note 3) 3.2	3.8	5.0	10.5	16.0	21.7	28.9	46.0	64.0	95.0	3.0	5.0	9.0	
	Permissible voltage fluctuation	3-phase or 1-phase 200 to 230VAC: 170 to 253VAC					3-phase 170 to 253VAC								1-phase 85 to 132VAC			
	Permissible frequency fluctuation	Within ±5%																
	Power supply capacity	Refer to section 10.2 "MR-J3-□B Servo Amplifier Instruction Manual"																
	Inrush current	Refer to section 10.5 "MR-J3-□B Servo Amplifier Instruction Manual"																
Control circuit power supply	Voltage, frequency	1-phase 200 to 230VAC, 50/60Hz												1-phase 100 to 120VAC, 50/60Hz				
	Rated current [A]	0.2						0.3						0.4				
	Permissible voltage fluctuation	1-phase 170 to 253VAC												1-phase 85 to 132VAC				
	Permissible frequency fluctuation	Within ±5%																
	Power consumption [W]	30						45						30				
	Inrush current	Refer to section 10.5 "MR-J3-□B Servo Amplifier Instruction Manual"																
Interface power supply	Voltage	24VDC±10%																
	Power supply capacity	(Note 1) 0.15A or more																
Load side encoder interface	Serial interface		Mitsubishi high-speed serial communication															
	Pulse train interface	Input signal	ABZ-phase differential input signal															
		Minimum phase differential [ns]	200															
Control System		Sine-wave PWM control, current control system																
Dynamic brake		Built-in										External option		Built-in				
Protective functions		Overcurrent shut-off, regenerative overvoltage shut-off, overload shut-off (electronic thermal relay), servo motor overheat protection, encoder error protection, regenerative brake error protection, undervoltage, instantaneous power failure protection, overspeed protection, excessive error protection																
Structure		Self-cooled, open (IP rating: IP00)					Force-cooling, open (IP rating: IP00)								Self-cooled, open (IP rating: IP00)			
Mounting closely (Note 2)		○																
Environmental conditions	Ambient temperature	In operation	[°C]	(Note 2) 0 to 55 (non-freezing)														
			[°F]	(Note 2) 32 to 131 (non-freezing)														
		In storage	[°C]	-20 to 65 (non-freezing)														
			[°F]	-4 to 149 (non-freezing)														
	Ambient humidity	In operation	90%RH or less (non-condensing)															
		In storage																
	Ambient	Indoors (no direct sunlight) Free from corrosive gas, flammable gas, oil mist, dust and dirt																
	Altitude	Max. 1000m above sea level																
Vibration	5.9m/s ² or less at 10 to 55Hz (directions of X, Y and Z axes)																	
Mass	[kg]	0.8	0.8	1.0	1.0	1.4	1.4	2.1	2.3	4.6	6.2	18	18	19	0.8	0.8	1.0	
	[lb]	1.76	1.76	2.21	2.21	3.09	3.09	4.63	5.07	10.1	13.7	39.7	39.7	41.9	1.76	1.76	2.21	

Note 1. 0.15A is the value applicable when all I/O signals are used. The current capacity can be decreased by reducing the number of I/O points.

2. When the servo amplifiers are mounting closely, operate them at the ambient temperatures of 0 to 45°C (32 to 113°F) or at 75% or a smaller effective load ratio.

3. When a UL/CSA-compliant servo motor is used in combination, the value is 2.9A.

1. FUNCTIONS AND CONFIGURATION

(2) 400V class

Item		Servo amplifier MR-J3-□-RJ006		60B4	100B4	200B4	350B4	500B4	700B4	11KB4	15KB4	22KB4	
Output	Rated voltage	3-phase 323VAC											
	Rated current [A]	1.5	2.8	5.4	8.6	14.0	17.0	32.0	41.0	63.0			
Main circuit power supply	Voltage/frequency	3-phase 380 to 480VAC, 50/60Hz											
	Rated current [A]	1.4	2.5	5.1	7.9	10.8	14.4	23.1	31.8	47.6			
	Permissible voltage fluctuation	3-phase 323 to 528VAC											
	Permissible frequency fluctuation	Within ±5%											
	Power supply capacity	Refer to section 10.2 "MR-J3-□B Servo Amplifier Instruction Manual"											
	Inrush current	Refer to section 10.5 "MR-J3-□B Servo Amplifier Instruction Manual"											
	Control circuit power supply	Voltage/frequency	1-phase 380 to 480VAC, 50/60Hz										
Rated current [A]		0.1					0.2						
Permissible voltage fluctuation		1-phase 323 to 528VAC											
Permissible frequency fluctuation		Within ±5%											
Power consumption [W]		30					45						
Inrush current		Refer to section 10.5 "MR-J3-□B Servo Amplifier Instruction Manual"											
Interface power supply	Voltage	24VDC ±10%											
	Power supply capacity	(Note) 0.15A or more											
Load side encoder interface	Serial interface		Mitsubishi high-speed serial communication										
	Pulse train interface	Input signal	ABZ-phase differential input signal										
		Minimum phase differential [ns]	200										
Control System		Sine-wave PWM control, current control system											
Dynamic brake		Built-in							External option				
Protective functions		Overcurrent shut-off, regenerative overvoltage shut-off, overload shut-off (electronic thermal relay), servo motor overheat protection, encoder error protection, regenerative brake error protection, undervoltage, instantaneous power failure protection, overspeed protection, excessive error protection											
Structure		Self-cooled, open (IP rating: IP00)				Force-cooling, open (IP rating: IP00)							
Environmental conditions	Ambient temperature	In operation	[°C]	0 to 55 (non-freezing)									
			[°F]	32 to 131 (non-freezing)									
		In storage	[°C]	-20 to 65 (non-freezing)									
			[°F]	-4 to 149 (non-freezing)									
	Ambient humidity	In operation	90%RH or less (non-condensing)										
		In storage											
	Ambient		Indoors (no direct sunlight) Free from corrosive gas, flammable gas, oil mist, dust and dirt										
	Altitude		Max. 1000m above sea level										
Vibration		5.9m/s ² or less at 10 to 55Hz (directions of X, Y and Z axes)											
Mass	[kg]		1.7	1.7	2.1	4.6	4.6	6.2	18	18	19		
	[lb]		3.75	3.75	4.63	10.1	10.1	13.7	39.7	39.7	41.9		

Note. 0.15A is the value applicable when all I/O signals are used. The current capacity can be decreased by reducing the number of I/O points.

1. FUNCTIONS AND CONFIGURATION

1.4 Function list

The following table lists the functions of this servo. For details of the functions, refer to the reference field.

Function	Description	Reference
High-resolution encoder	High-resolution encoder of 262144 pulses/rev is used as a servo motor encoder.	
Absolute position detection system	Merely setting a home position once makes home position return unnecessary at every power-on.	Refer to the MR-J3-□B Servo Amplifier Instruction Manual.
Gain changing function	You can switch between gains during rotation and gains during stop or use an external signal to change gains during operation.	
Advanced vibration suppression control	This function suppresses vibration at the arm end or residual vibration.	
Adaptive filter II	Servo amplifier detects mechanical resonance and sets filter characteristics automatically to suppress mechanical vibration.	
Low-pass filter	Suppresses high-frequency resonance which occurs as servo system response is increased.	
Machine analyzer function	Analyzes the frequency characteristic of the mechanical system by simply connecting a MR Configurator-installed personal computer and servo amplifier. MR Configurator is necessary for this function.	
Machine simulation	Can simulate machine motions on a personal computer screen on the basis of the machine analyzer results. MR Configurator is necessary for this function.	
Gain search function	Personal computer changes gains automatically and searches for overshoot-free gains in a short time. MR Configurator is necessary for this function.	
Robust disturbance compensation	This function provides better disturbance response in case of low response level due to high load inertia moment ratio for the roll send axes. MR Configurator is necessary for this function.	
Advanced Gain search	Advanced Gain search automatically searches for the optimum parameter for settle time to be short. The gain can be adjusted by setting sequentially in accordance with wizard screens. MR Configurator is necessary for this function.	
Slight vibration suppression control	Suppresses vibration of ± 1 pulse produced at a servo motor stop.	Refer to the MR-J3-□B Servo Amplifier Instruction Manual.
Auto tuning	Automatically adjusts the gain to optimum value if load applied to the servo motor shaft varies. Higher in performance than MR-J2-Super series servo amplifier.	
Brake unit	Used when the regenerative option cannot provide enough regenerative power. Can be used the 5kW or more servo amplifier.	
Power regenerative converter	Used when the regenerative option cannot provide enough regenerative power. Can be used the 5kW or more servo amplifier.	
Regenerative option	Used when the built-in regenerative resistor of the servo amplifier does not have sufficient regenerative capability for the regenerative power generated.	
Alarm history clear	Alarm history is cleared.	
Output signal selection (Device settings)	The pins that output the output devices, including the trouble (ALM) and the dynamic brake interlock (MBR), can be changed to certain pins of the CN3 connectors.	
Output signal (DO) forced output	Output signal can be forced on/off independently of the servo status. Use this function for output signal wiring check, etc.	
Test operation mode	JOG operation • positioning operation • DO forced output • program operation. However, MR Configurator is necessary for positioning operation.	
Analog monitor output	Servo status is output in terms of voltage in real time.	
MR Configurator	Using a personal computer, parameter setting, test operation, status display, etc. can be performed.	

1. FUNCTIONS AND CONFIGURATION

1.5 Selecting procedure of control mode

1.5.1 Control mode configuration

In this servo, a semi closed loop system or fully closed loop system can be selected as a control system. Also, on the fully closed loop system, the semi closed loop control, fully closed loop control and dual feedback control can be switched by the parameter No.PE08 settings.

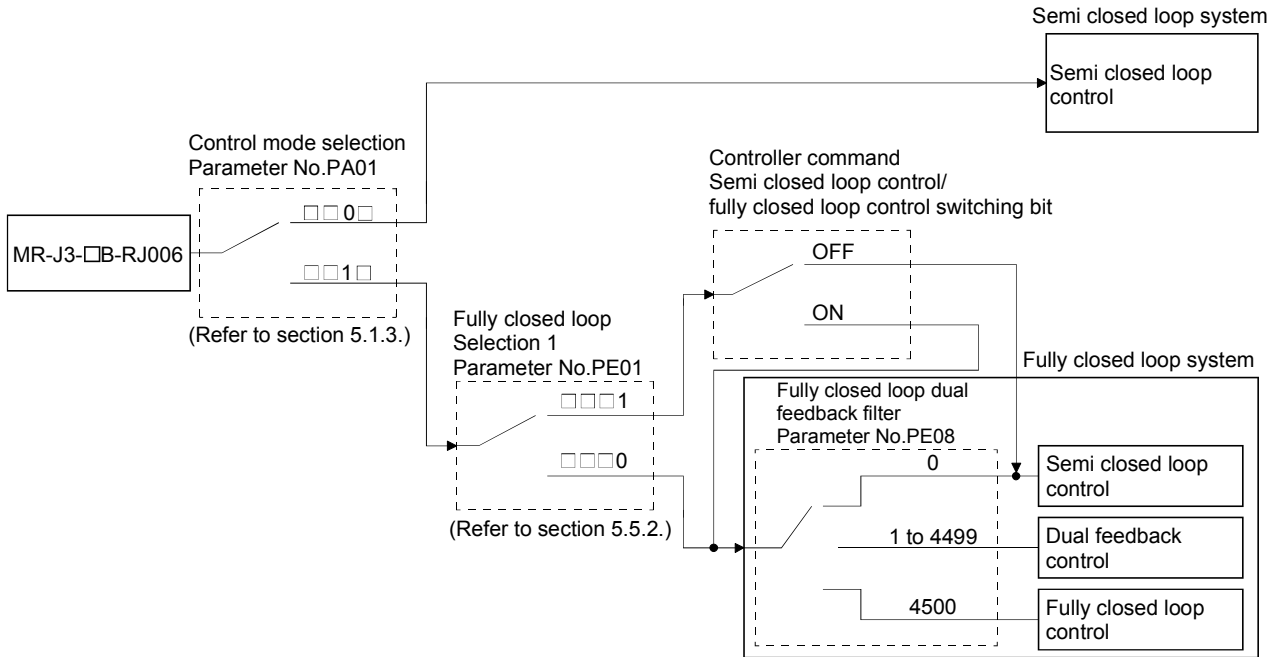

1.5.2 Dual feedback filter equivalent block diagram

A dual feedback filter equivalent block diagram on the dual feedback control is shown below.

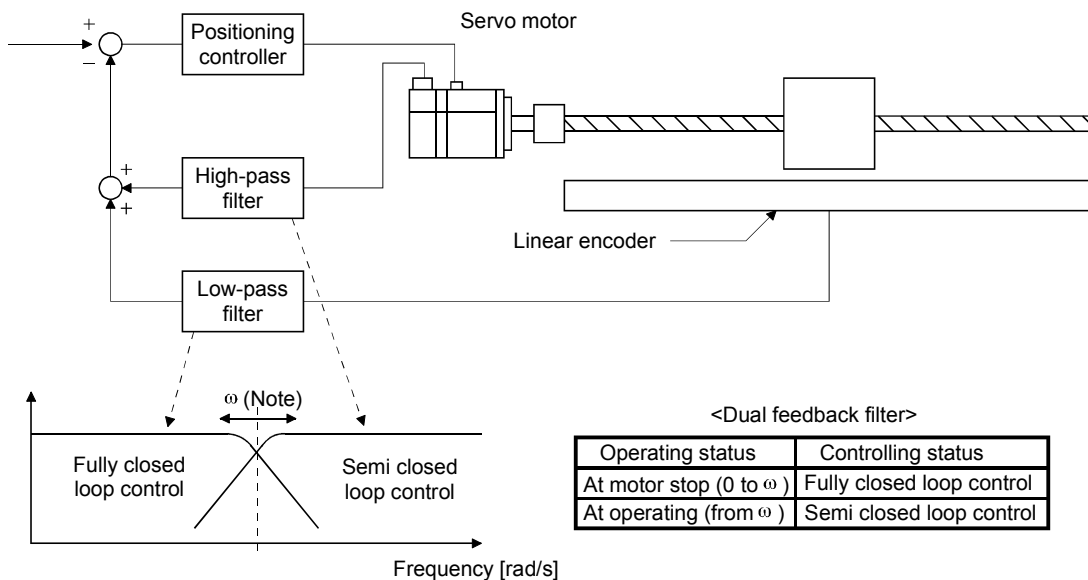

Note. ω (a dual feedback filter band) is set by parameter No.PE08.

1. FUNCTIONS AND CONFIGURATION

1.6 Model code definition

(1) Rating plate

MITSUBISHI AC SERVO	
MODEL	MR-J3-10B-RJ006
POWER : 100W	
INPUT : 0.9A 3PH+1PH 200-230V 50Hz	
3PH+1PH 200-230V 60Hz	
1.3A 1PH 200-230V 50/60Hz	
OUTPUT: 170V 0-360Hz 1.1A	
SERIAL	A34230001
 MITSUBISHI ELECTRIC CORPORATION MADE IN JAPAN	
PASSED	

Model

Capacity

Applicable power supply

Rated output current

Serial number

(2) Model

MR - J3 - □ B □ □

Series

Fully closed loop control symbol

Symbol	Standard regeneration brake resistor	
	0.1kW to 7kW	11kW to 2kW
RJ006	Built-in (No built-in for 0.1kW)	Standard attachment
RZ006	No attachment	

Power supply

Symbol	Power supply
None (Note 1)	3-phase or 1-phase 200 to 230VAC
(Note 2) 1	1-phase 100 to 120VAC
(Note 3) 4	3-phase 380 to 480VAC

Note 1. 1-phase 200V to 230V is supported by 750W or less.
 Note 2. 1-phase 100V to 120V is supported by 400W or less.
 Note 3. 3-phase 380VAC to 480VAC is supported by 600W and 1kW or more.

SSCNET III compatible

Rated output

Symbol	Rated output [kW]	Symbol	Rated output [kW]
10	0.1	350	3.5
20	0.2	500	5
40	0.4	700	7
60	0.6	11k	11
70	0.75	15k	15
100	1	22k	22
200	2		

1. FUNCTIONS AND CONFIGURATION

1.7 Combination with servo motor

The following table lists combinations of servo amplifiers and servo motors. The same combinations apply to the models with an electromagnetic brake and the models with a reduction gear.

Servo amplifier	Servo motors						
	HF-KP□	HF-MP□	HF-SP□		HC-RP□	HC-UP□	HC-LP□
			1000r/min	2000r/min			
MR-J3-10B (1) -RJ006	053 · 13	053 · 13					
MR-J3-20B (1) -RJ006	23	23					
MR-J3-40B (1) -RJ006	43	43					
MR-J3-60B-RJ006			51	52			52
MR-J3-70B-RJ006	73	73				72	
MR-J3-100B-RJ006			81	102			102
MR-J3-200B-RJ006			121 · 201	152 · 202	103 · 153	152	152
MR-J3-350B-RJ006			301	352	203	202	202
MR-J3-500B-RJ006			421	502	353 · 503	352 · 502	302
MR-J3-700B-RJ006				702			

Servo amplifier	Servo motors		
	HA-LP□		
	1000r/min	1500r/min	2000r/min
MR-J3-500B-RJ006			502
MR-J3-700B-RJ006	601	701M	702
MR-J3-11KB-RJ006	801 · 12K1	11K1M	11K2
MR-J3-15KB-RJ006	15K1	15K1M	15K2
MR-J3-22KB-RJ006	20K1 · 25K1	22K1M	22K2

Servo amplifier	Servo motors			
	HF-SP□	HA-LP□		
		1000r/min	1500r/min	2000r/min
MR-J3-60B4-RJ006	524			
MR-J3-100B4-RJ006	1024			
MR-J3-200B4-RJ006	1524 · 2024			
MR-J3-350B4-RJ006	3524			
MR-J3-500B4-RJ006	5024			
MR-J3-700B4-RJ006	7024	6014	701M4	
MR-J3-11KB4-RJ006		8014 · 12K14	11K1M4	11K24
MR-J3-15KB4-RJ006		15K14	15K1M4	15K24
MR-J3-22KB4-RJ006		20K14	22K1M4	22K24

1. FUNCTIONS AND CONFIGURATION

1.8 Structure

1.8.1 Parts identification

(1) MR-J3-100B-RJ006 or less

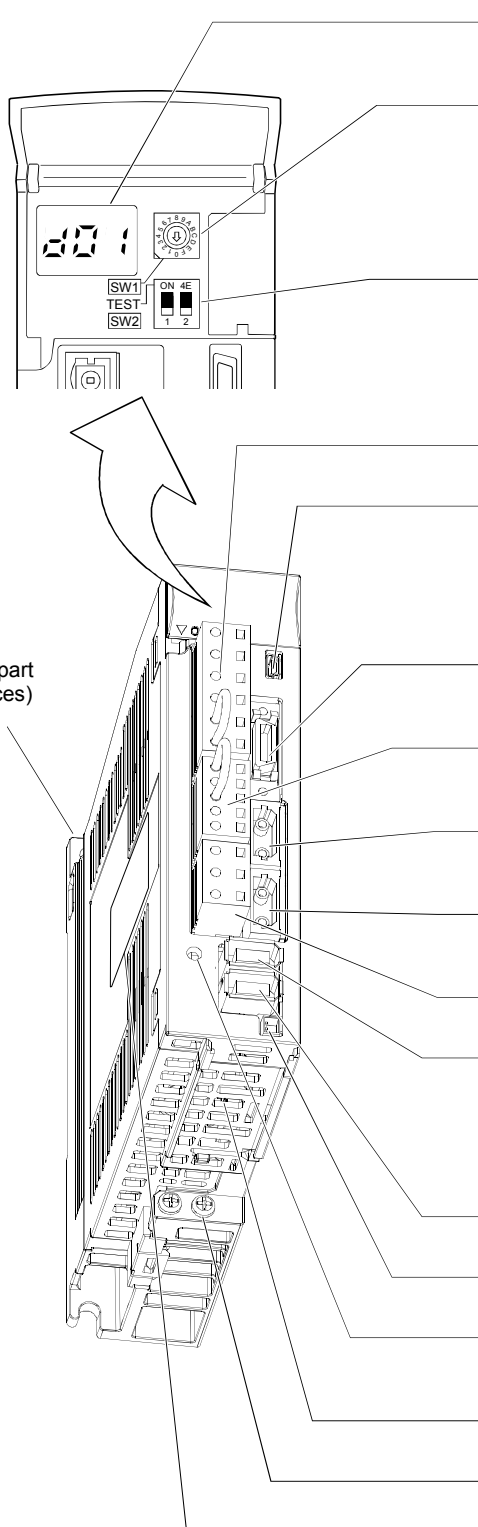

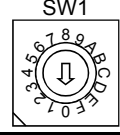
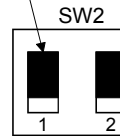

Fixed part (2 places)

Name/Application	Detailed explanation
Display The 3-digit, seven-segment LED shows the servo status and alarm number.	Refer to the MR-J3-□B Servo Amplifier Instruction Manual.
Rotary axis setting switch (SW1) SW1  Used to set the axis No. of servo amplifier.	
Test operation select switch (SW2-1) SW2  Used to perform the test operation mode by using MR Configurator. Spare (Be sure to set to the "Down" position).	
Main circuit power supply connector (CNP1) Connect the input power supply.	Section 2.2
USB communication connector (CN5) Connect the personal computer.	Refer to the MR-J3-□B Servo Amplifier Instruction Manual.
I/O signal connector (CN3) Used to connect digital I/O signals. More over an analog monitor is output.	Section 2.3 Section 2.4
Control circuit connector (CNP2) Connect the control circuit power supply/regenerative option.	Section 2.2
SSCNET III cable connector (CN1A) Used to connect the servo system controller or the front axis servo amplifier.	Refer to the MR-J3-□B Servo Amplifier Instruction Manual.
SSCNET III cable connector (CN1B) Used to connect the rear axis servo amplifier. For the final axis, puts a cap.	
Servo motor power connector (CNP3) Connect the servo motor.	Section 2.2
Encoder connector (CN2) Used to connect the servo motor encoder.	Refer to the MR-J3-□B Servo Amplifier Instruction Manual.
Load side encoder connector (CN2L) Connect the load side encoder.	Chapter 3
Connector for manufacturer setting Not used for this servo amplifier.	
Charge lamp Lit to indicate that the main circuit is charged. While this lamp is lit, do not reconnect the cables.	
Battery holder Not used for this servo amplifier.	
Protective earth (PE) terminal (⊕) Ground terminal.	Section 2.2
Rating plate	Section 1.6

1. FUNCTIONS AND CONFIGURATION

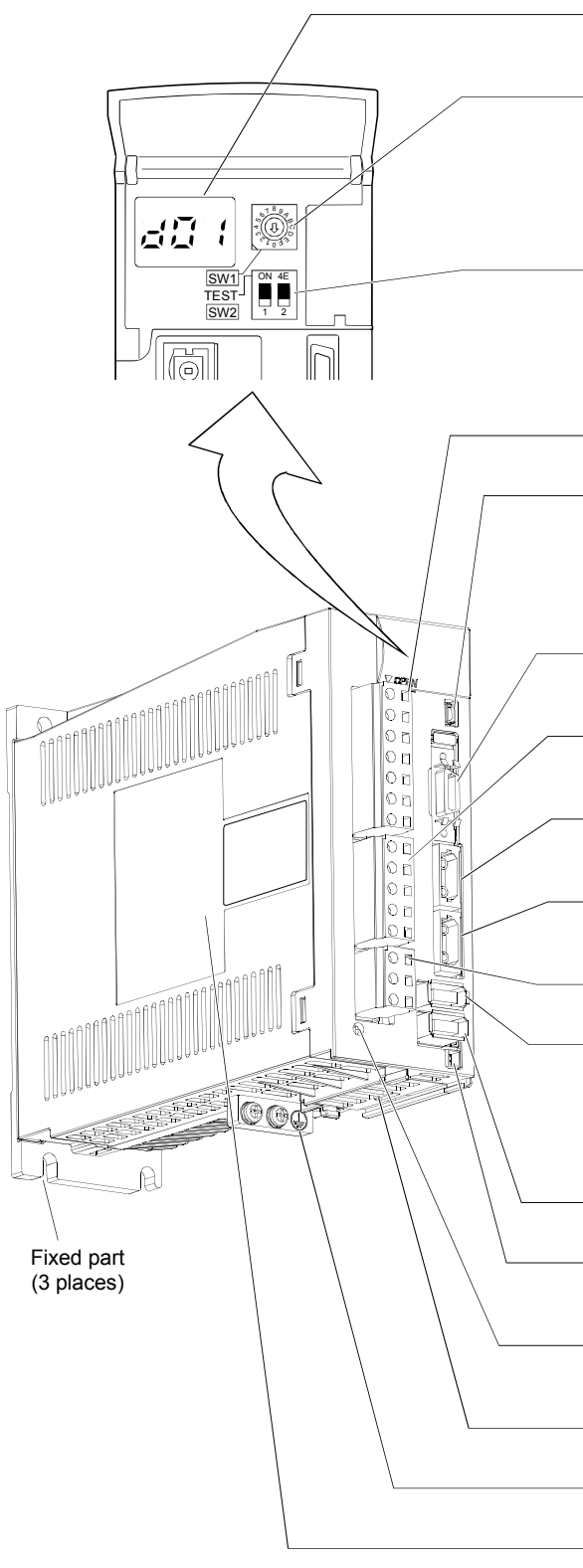
(2) MR-J3-60B4-RJ006 • MR-J3-100B4-RJ006

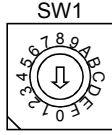
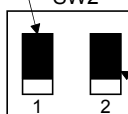

Name/Application	Detailed explanation
Display The 3-digit, seven-segment LED shows the servo status and alarm number.	Refer to the MR-J3-□B Servo Amplifier Instruction Manual.
Rotary axis setting switch (SW1) SW1  Used to set the axis No. of servo amplifier.	
Test operation select switch (SW2-1) SW2  Used to perform the test operation mode by using MR Configurator.	
Spare (Be sure to set to the "Down" position). 	
Main circuit power supply connector (CNP1) Connect the input power supply.	Section 2.2
USB communication connector (CN5) Connect the personal computer.	Refer to the MR-J3-□B Servo Amplifier Instruction Manual.
I/O signal connector (CN3) Used to connect digital I/O signals. More over an analog monitor is output.	Section 2.3 Section 2.4
Control circuit connector (CNP2) Connect the control circuit power supply/regenerative option.	Section 2.2
SSCNET III cable connector (CN1A) Used to connect the servo system controller or the front axis servo amplifier.	Refer to the MR-J3-□B Servo Amplifier Instruction Manual.
SSCNET III cable connector (CN1B) Used to connect the rear axis servo amplifier. For the final axis, puts a cap.	
Servo motor power connector (CNP3) Connect the servo motor.	Section 2.2
Encoder connector (CN2) Used to connect the servo motor encoder.	Refer to the MR-J3-□B Servo Amplifier Instruction Manual.
Load side encoder connector (CN2L) Connect the load side encoder.	Chapter 3
Battery connector (CN4) Used to connect the battery for absolute position data backup.	
Charge lamp Lit to indicate that the main circuit is charged. While this lamp is lit, do not reconnect the cables.	
Battery holder Contains the battery for absolute position data backup.	
Protective earth (PE) terminal (⊕) Ground terminal.	Section 2.2
Rating plate	Section 1.6

Fixed part (3 places)

1. FUNCTIONS AND CONFIGURATION

(3) MR-J3-200B(4)-RJ006

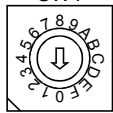
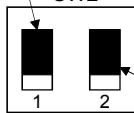
Name/Application	Detailed explanation
Display The 3-digit, seven-segment LED shows the servo status and alarm number.	Refer to the MR-J3-□B Servo Amplifier Instruction Manual.
Rotary axis setting switch (SW1) SW1  Used to set the axis No. of servo amplifier.	
Test operation select switch (SW2-1) SW2  Used to perform the test operation mode by using MR Configurator.	
Spare (Be sure to set to the "Down" position).	
Main circuit power supply connector (CNP1) Connect the input power supply.	Section 2.2
USB communication connector (CN5) Connect the personal computer.	Refer to the MR-J3-□B Servo Amplifier Instruction Manual.
I/O signal connector (CN3) Used to connect digital I/O signals. More over an analog monitor is output.	Section 2.3 Section 2.4
Control circuit connector (CNP2) Connect the control circuit power supply/regenerative option.	Section 2.2
SSCNET III cable connector (CN1A) Used to connect the servo system controller or the front axis servo amplifier.	Refer to the MR-J3-□B Servo Amplifier Instruction Manual.
SSCNET III cable connector (CN1B) Used to connect the rear axis servo amplifier. For the final axis, puts a cap.	
Encoder connector (CN2) Used to connect the servo motor encoder.	Chapter 3
Load side encoder connector (CN2L) Connect the load side encoder.	
Battery connector (CN4) Used to connect the battery for absolute position data backup.	
Servo motor power connector (CNP3) Connect the servo motor.	
Battery holder Contains the battery for absolute position data backup.	
Charge lamp Lit to indicate that the main circuit is charged. While this lamp is lit, do not reconnect the cables.	Section 2.2
Protective earth (PE) terminal (⊕) Ground terminal.	
Rating plate	Section 1.6

Fixed part (3 places)

Cooling Fan

(Note)

Note. Connectors (CNP1, CNP2, and CNP3) and appearance of MR-J3-200B-RJ006 servo amplifier have been changed from April 2008 production. For existing servo amplifier, refer to appendix 4.

1. FUNCTIONS AND CONFIGURATION

(4) MR-J3-350B-RJ006

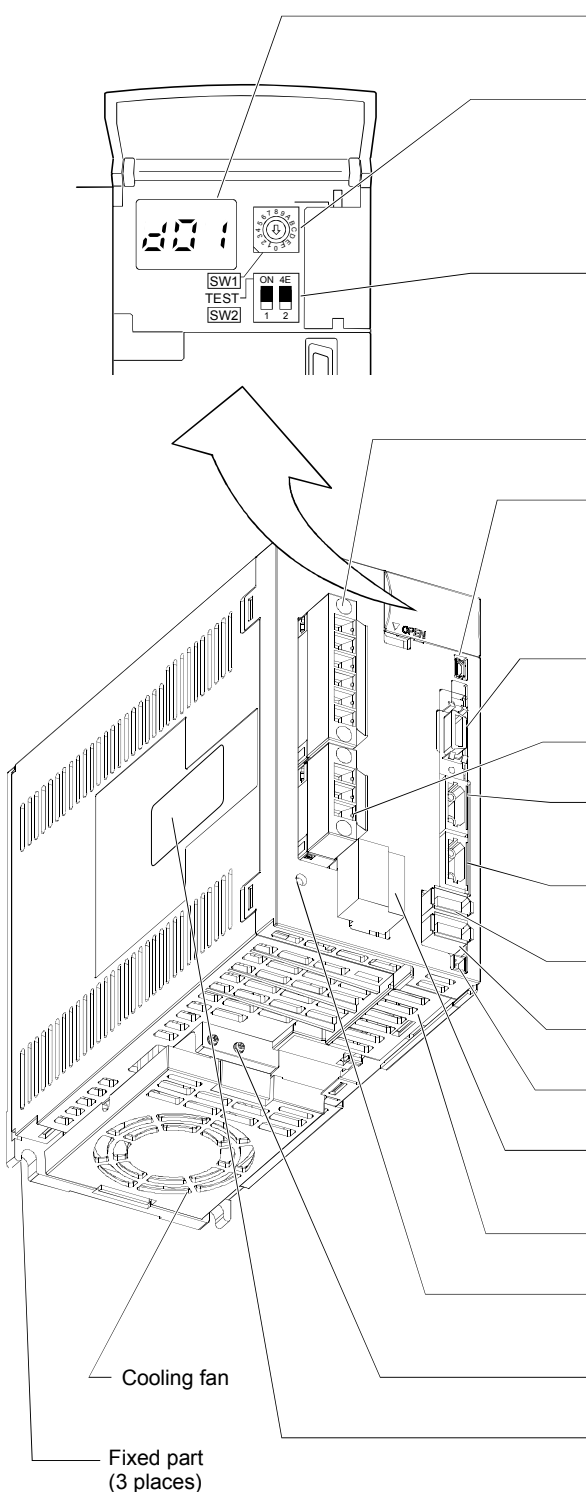

The diagram illustrates the MR-J3-350B-RJ006 servo amplifier. The top portion shows the front panel with a 3-digit LED display, a rotary axis setting switch (SW1), and two test operation select switches (SW2-1 and SW2-2). The bottom portion shows the rear panel with various connectors: CNP1 (Main circuit power supply), CN5 (USB communication), CN3 (I/O signal), CNP3 (Servo motor power), CN1A and CN1B (SSCNET III cable), CN2 (Encoder), CN2L (Load side encoder), CN4 (Manufacturer setting), CNP2 (Control circuit power supply/regenerative option), a battery holder, a charge lamp, a protective earth (PE) terminal, and a rating plate. A cooling fan and three fixed parts are also indicated.

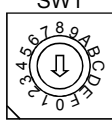
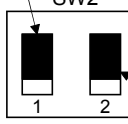
Name/Application	Detailed explanation
Display The 3-digit, seven-segment LED shows the servo status and alarm number.	Refer to the MR-J3-□B Servo Amplifier Instruction Manual.
Rotary axis setting switch (SW1) SW1  Used to set the axis No. of servo amplifier.	
Test operation select switch (SW2-1) Used to perform the test operation mode by using MR Configurator. SW2  Spare (Be sure to set to the "Down" position).	
Main circuit power supply connector (CNP1) Connect the input power supply.	Section 2.2
USB communication connector (CN5) Connect the personal computer.	Refer to the MR-J3-□B Servo Amplifier Instruction Manual.
I/O signal connector (CN3) Used to connect digital I/O signals. More over an analog monitor is output.	Section 2.3 Section 2.4
Servo motor power connector (CNP3) Connect the servo motor.	Section 2.2
SSCNET III cable connector (CN1A) Used to connect the servo system controller or the front axis servo amplifier.	Refer to the MR-J3-□B Servo Amplifier Instruction Manual.
SSCNET III cable connector (CN1B) Used to connect the rear axis servo amplifier. For the final axis, puts a cap.	
Encoder connector (CN2) Used to connect the servo motor encoder.	Chapter 3
Load side encoder connector (CN2L) Connect the load side encoder.	
Connector for manufacturer setting (CN4) Not used for this servo amplifier.	
Control circuit connector (CNP2) Connect the control circuit power supply/regenerative option.	Section 2.2
Battery holder Not used for this servo amplifier.	
Charge lamp Lit to indicate that the main circuit is charged. While this lamp is lit, do not reconnect the cables.	
Protective earth (PE) terminal (⊕) Ground terminal.	Section 2.2
Rating plate	Section 1.6

1. FUNCTIONS AND CONFIGURATION

(5) MR-J3-350B4-RJ006 • MR-J3-500B(4)-RJ006

POINT

- The servo amplifier is shown without the front cover. For removal of the front cover, refer to section 1.8.2 of the MR-J3-□B Servo Amplifier Instruction Manual.

Name/Application	Detailed explanation
Display The 3-digit, seven-segment LED shows the servo status and alarm number.	Refer to the MR-J3-□B Servo Amplifier Instruction Manual.
Rotary axis setting switch (SW1) SW1 Used to set the axis No. of servo amplifier.	
Test operation select switch (SW2-1) Used to perform the test operation mode by using MR Configurator. SW2 Spare (Be sure to set to the "Down" position).	
USB communication connector (CN5) Connect the personal computer.	
I/O signal connector (CN3) Used to connect digital I/O signals. More over an analog monitor is output.	Section 2.3 Section 2.4
Battery holder Not used for this servo amplifier.	/
SSCNET III cable connector (CN1A) Used to connect the servo system controller or the front axis servo amplifier.	Refer to the MR-J3-□B Servo Amplifier Instruction Manual.
SSCNET III cable connector (CN1B) Used to connect the rear axis servo amplifier. For the final axis, puts a cap.	
Encoder connector (CN2) Used to connect the servo motor encoder.	
Load side encoder connector (CN2L) Connect the load side encoder.	Chapter 3
Connector for manufacturer setting (CN4) Not used for this servo amplifier.	/
Power factor improving DC reactor terminal block (TE3) Used to connect the power factor improving DC reactor.	Refer to the MR-J3-□B Servo Amplifier Instruction Manual.
Charge lamp Lit to indicate that the main circuit is charged. While this lamp is lit, do not reconnect the cables.	/
Main circuit terminal block (TE1) Used to connect the input power supply and servo motor.	Section 2.2
Control circuit terminal block (TE2) Used to connect the control circuit power supply.	
Protective earth (PE) terminal (⊕) Ground terminal.	
Rating plate	Section 1.6

1. FUNCTIONS AND CONFIGURATION

(6) MR-J3-700B(4)-RJ006

POINT

- The servo amplifier is shown without the front cover. For removal of the front cover, refer to section 1.8.2 of the MR-J3-□B Servo Amplifier Instruction Manual.

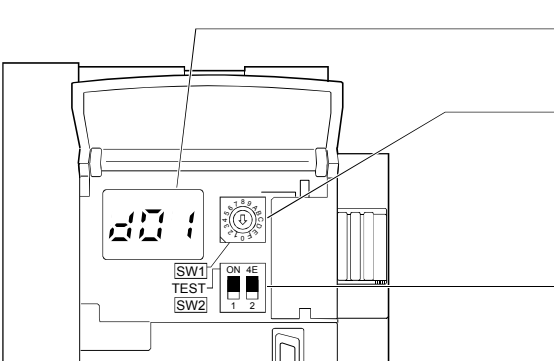
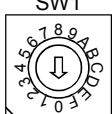
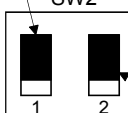
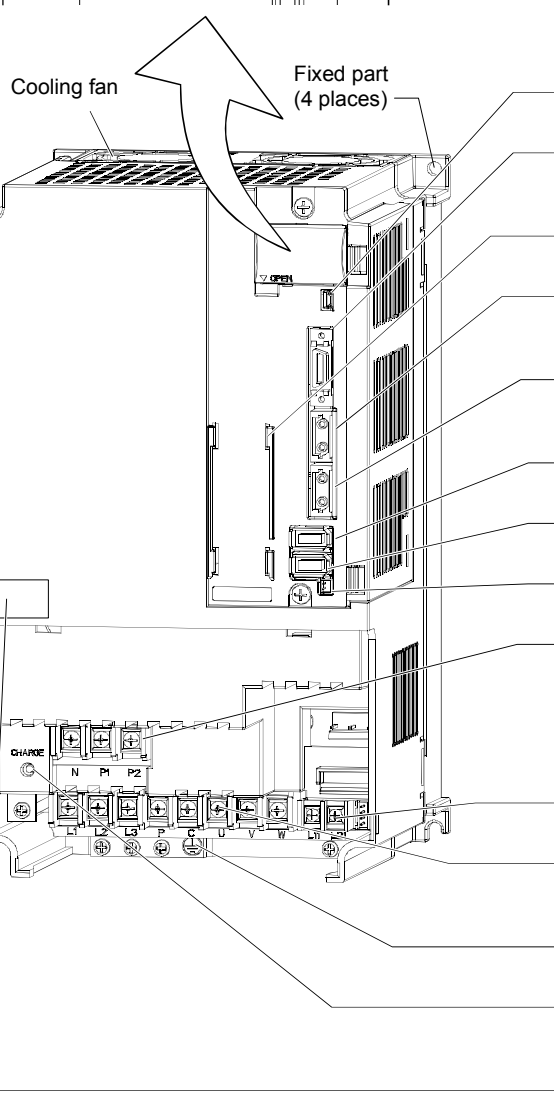
	Name/Application	Detailed explanation
	Display The 3-digit, seven-segment LED shows the servo status and alarm number.	Refer to the MR-J3-□B Servo Amplifier Instruction Manual.
	Rotary axis setting switch (SW1)  Used to set the axis No. of servo amplifier.	
	Test operation select switch (SW2-1)  Used to perform the test operation mode by using MR Configurator.	
	Spare (Be sure to set to the "Down" position).	
	USB communication connector (CN5) Connect the personal computer.	Section 2.3 Section 2.4
	I/O signal connector (CN3) Used to connect digital I/O signals. More over an analog monitor is output.	
	Battery holder Contains the battery for absolute position data backup.	
	SSCNET III cable connector (CN1A) Used to connect the servo system controller or the front axis servo amplifier.	Refer to the MR-J3-□B Servo Amplifier Instruction Manual.
	SSCNET III cable connector (CN1B) Used to connect the rear axis servo amplifier. For the final axis, puts a cap.	
	Encoder connector (CN2) Used to connect the servo motor encoder.	Chapter 3
	Load side encoder connector (CN2L) Connect the load side encoder.	
	Connector for manufacturer setting (CN4) Not used for this servo amplifier.	
	Power factor improving DC reactor terminal block (TE3) Used to connect the power factor improving DC reactor.	Refer to the MR-J3-□B Servo Amplifier Instruction Manual.
	Control circuit terminal block (TE2) Used to connect the control circuit power supply.	Section 2.2
	Main circuit terminal block (TE1) Used to connect the input power supply and servo motor.	
	Protective earth (PE) terminal (⊕) Ground terminal.	
Charge lamp Lit to indicate that the main circuit is charged. While this lamp is lit, do not reconnect the cables.		
Rating plate	Section 1.6	

1. FUNCTIONS AND CONFIGURATION

(7) MR-J3-11KB (4)-RJ006 to MR-J3-22KB(4)-RJ006

POINT
<ul style="list-style-type: none"> The servo amplifier is shown without the front cover. For removal of the front cover, refer to section 1.8.2 of the MR-J3-□B Servo Amplifier Instruction Manual.

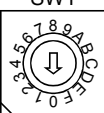
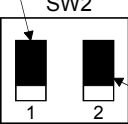
Name/Application	Detailed explanation
Display The 3-digit, seven-segment LED shows the servo status and alarm number.	Refer to the MR-J3-□B Servo Amplifier Instruction Manual.
Rotary axis setting switch (SW1) SW1  Used to set the axis No. of servo amplifier.	
Test operation select switch (SW2-1) SW2  Used to perform the test operation mode by using MR Configurator.	
Spare (Be sure to set to the "Down" position).	
USB communication connector (CN5) Connect the personal computer.	
I/O signal connector (CN3) Used to connect digital I/O signals. More over an analog monitor is output.	Section 2.3 Section 2.4
Battery holder Contains the battery for absolute position data backup.	
SSCNET III cable connector (CN1A) Used to connect the servo system controller or the front axis servo amplifier.	Refer to the MR-J3-□B Servo Amplifier Instruction Manual.
SSCNET III cable connector (CN1B) Used to connect the rear axis servo amplifier. For the final axis, puts a cap.	
Encoder connector (CN2) Used to connect the servo motor encoder.	
Load side encoder connector (CN2L) Connect the load side encoder.	Chapter 3
Connector for manufacturer setting (CN4) Not used for this servo amplifier.	
Charge lamp Lit to indicate that the main circuit is charged. While this lamp is lit, do not reconnect the cables.	
Rating plate	Section 1.6
Main circuit, Control circuit and Protective earth (PE) terminal block (TE) Used to connect the input power supply, servo motor, regenerative option, and grounding.	Section 2.2

1. FUNCTIONS AND CONFIGURATION

1.8.2 Removal and reinstallation of the front cover



WARNING

▪ Before removing or installing the front cover, turn off the power and wait for 15 minutes or more until the charge lamp turns off. Then, confirm that the voltage between P(+) and N(−) is safe with a voltage tester and others. Otherwise, an electric shock may occur. In addition, always confirm from the front of the servo amplifier whether the charge lamp is off or not.

(1) For MR-J3-350B4-RJ006 • MR-J3-500B(4)-RJ006 • MR-J3-700B(4)-RJ006

Removal of the front cover

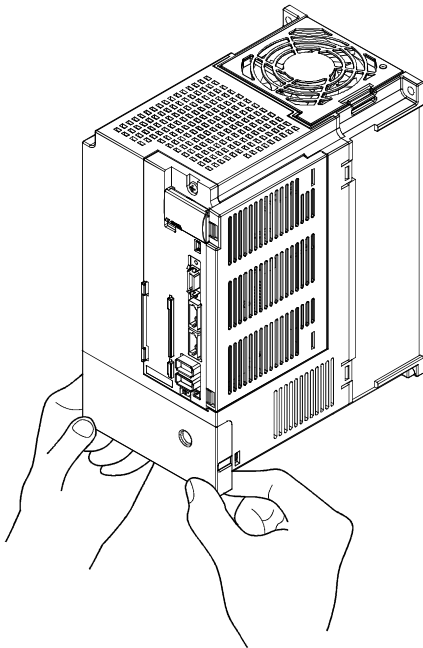

1) Hold the ends of lower side of the front cover with both hands.

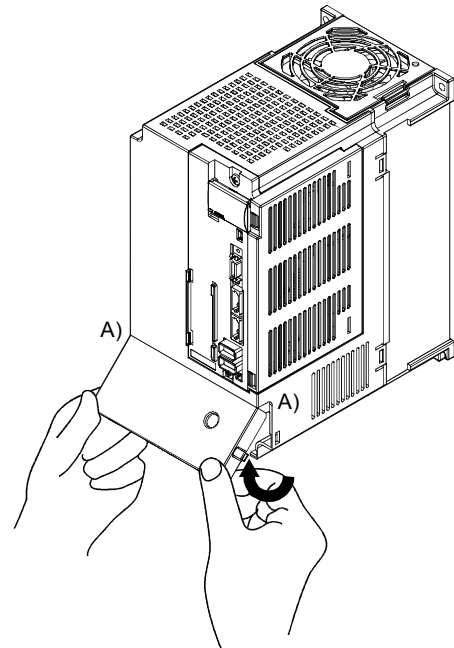

2) Pull up the cover, supporting at point A).

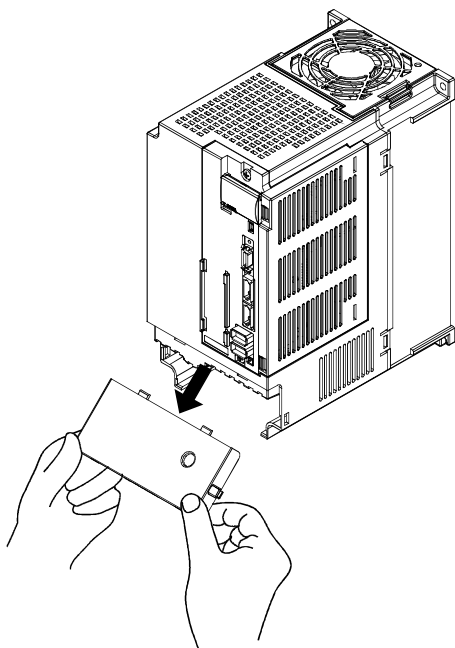

3) Pull out the front cover to remove.

1. FUNCTIONS AND CONFIGURATION

Reinstallation of the front cover

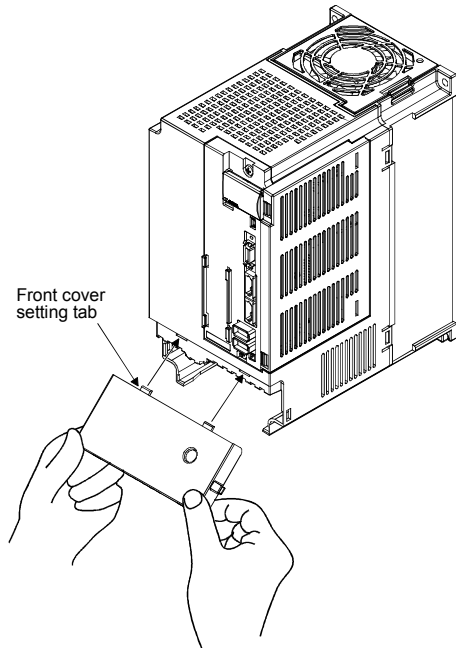

1) Insert the setting tabs on the front cover into the sockets of the servo amplifier (2 places).

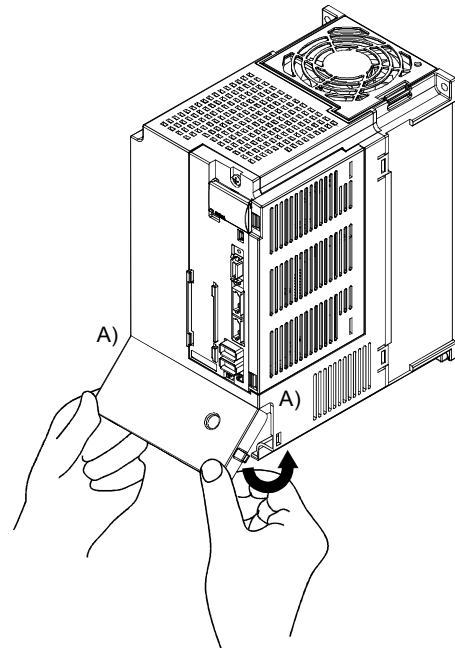

2) Pull up the cover, supporting at point A).

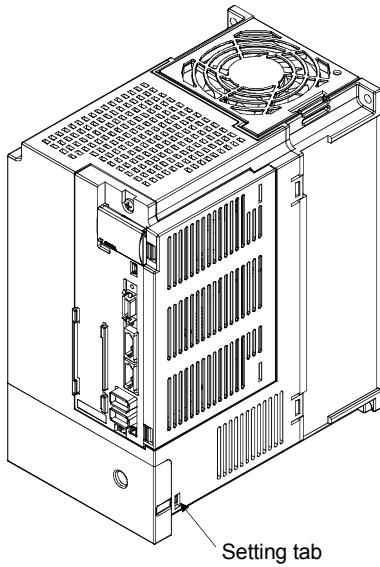

3) Push the setting tabs until they click.

1. FUNCTIONS AND CONFIGURATION

(2) For MR-J3-11KB(4)-RJ006 to MR-J3-22KB(4)-RJ006

Removal of the front cover

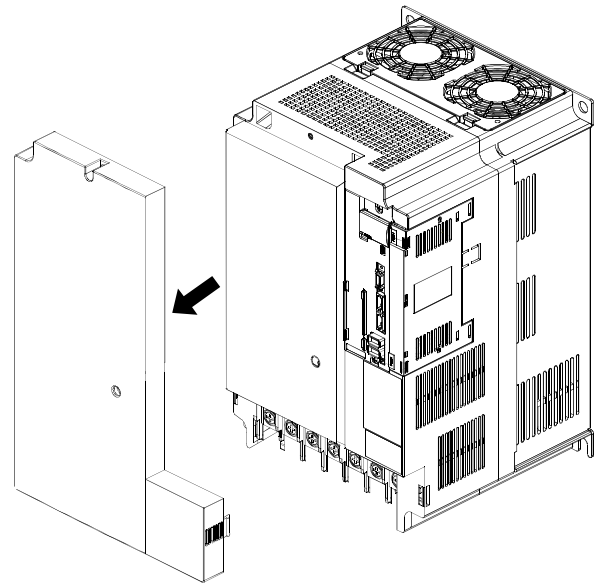
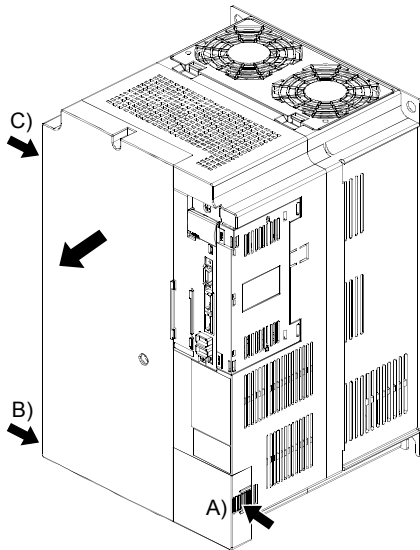

- 1) Press the removing knob on the lower side of the front cover (A) and B) and release the setting tabs.
- 2) Press the removing knob of C) and release the setting tabs.

- 3) Pull it to remove the front cover.

Reinstallation of the front cover

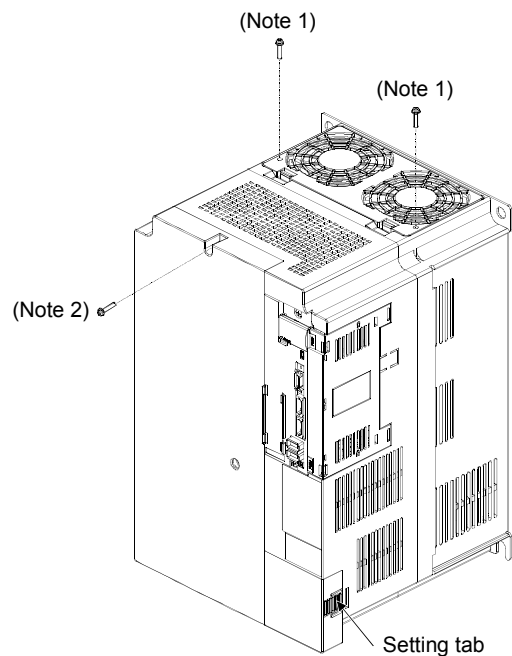
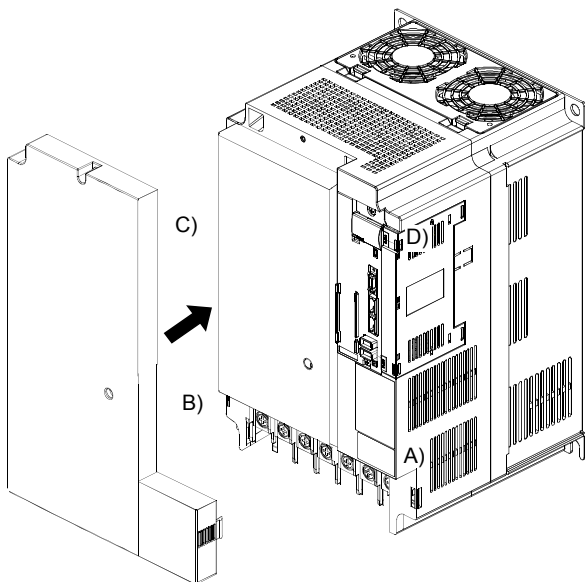

- 1) Fit the front cover setting tabs on the sockets of body cover (A) to D)) to reinstall it.

- 2) Push the front cover until you hear the clicking noise of the setting tabs.

Note 1. The cooling fan cover can be locked with enclosed screws (M4 × 40).

2. By drilling approximately $\phi 4$ of a hole on the front cover, the front cover can be locked on the body with an enclosed screw (M4 × 40).

1. FUNCTIONS AND CONFIGURATION

1.9 Configuration including auxiliary equipment

POINT
<ul style="list-style-type: none"> Equipment other than the servo amplifier and servo motor are optional or recommended products.

(1) MR-J3-100B-RJ006 or less

(a) For 3-phase or 1-phase 200V to 230VAC

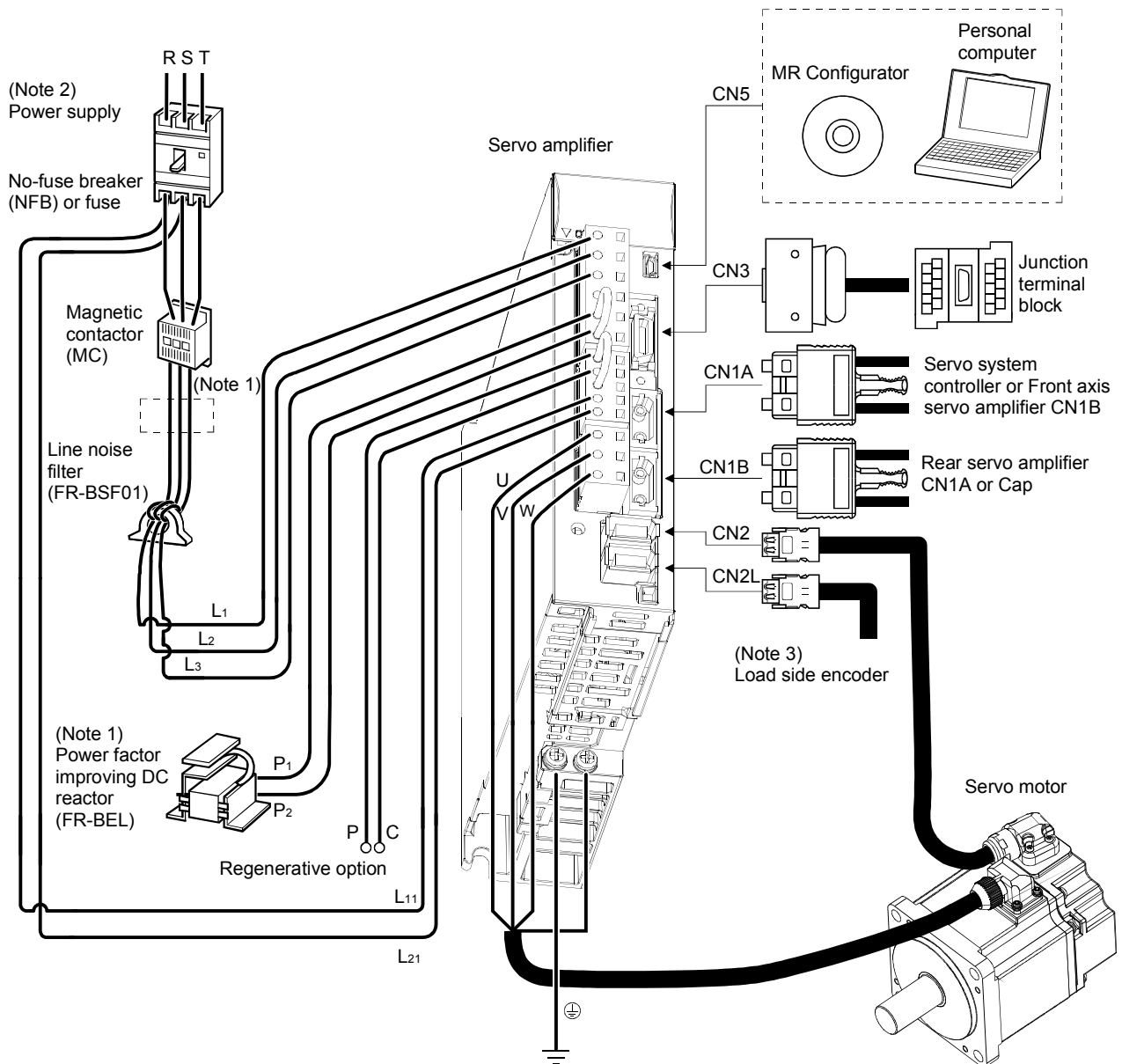

Note 1. The power factor improving AC reactor can also be used. In this case, the power factor improving DC reactor cannot be used. When not using the power factor improving DC reactor, short P1 and P2.

Note 2. A 1-phase 200V to 230VAC power supply may be used with the servo amplifier of MR-J3-70B-RJ006 or less. For 1-phase 200V to 230VAC, connect the power supply to L1 and L2 and leave L3 open. Refer to section 1.3 for the power supply specification.

Note 3. For the configuration of the ABZ-phase pulse train interface or serial communication specification linear encoder/rotary encoder, refer to section 1.10.

1. FUNCTIONS AND CONFIGURATION

(b) For 1-phase 100V to 120VAC

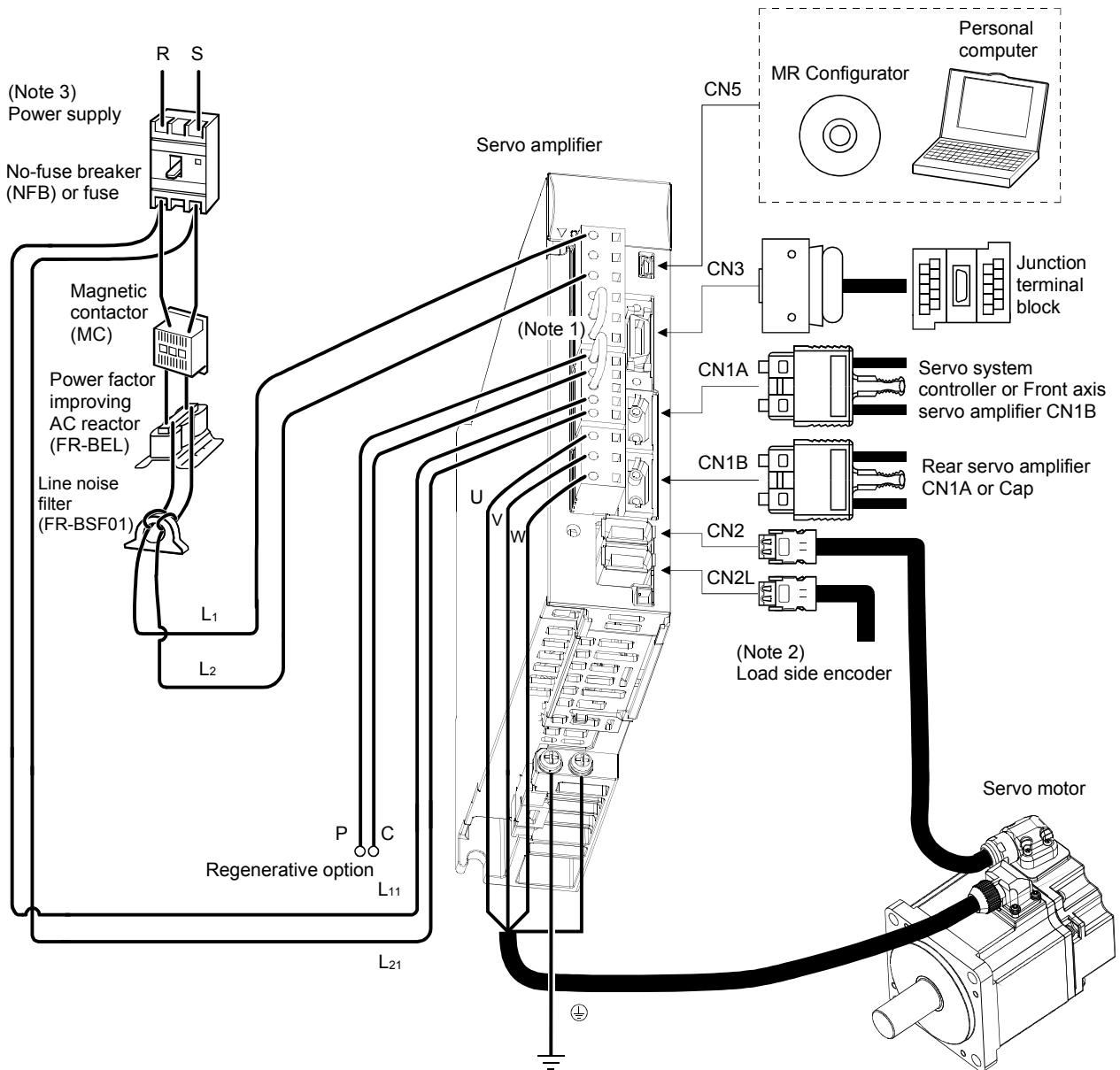

Note 1. The power factor improving DC reactor cannot be used.

2. For the configuration of the ABZ-phase pulse train interface or serial communication specification linear encoder/rotary encoder, refer to section 1.10.

3. Refer to section 1.3 for the power supply specification.

1. FUNCTIONS AND CONFIGURATION

(2) MR-J3-60B4-RJ006 • MR-J3-100B4-RJ006

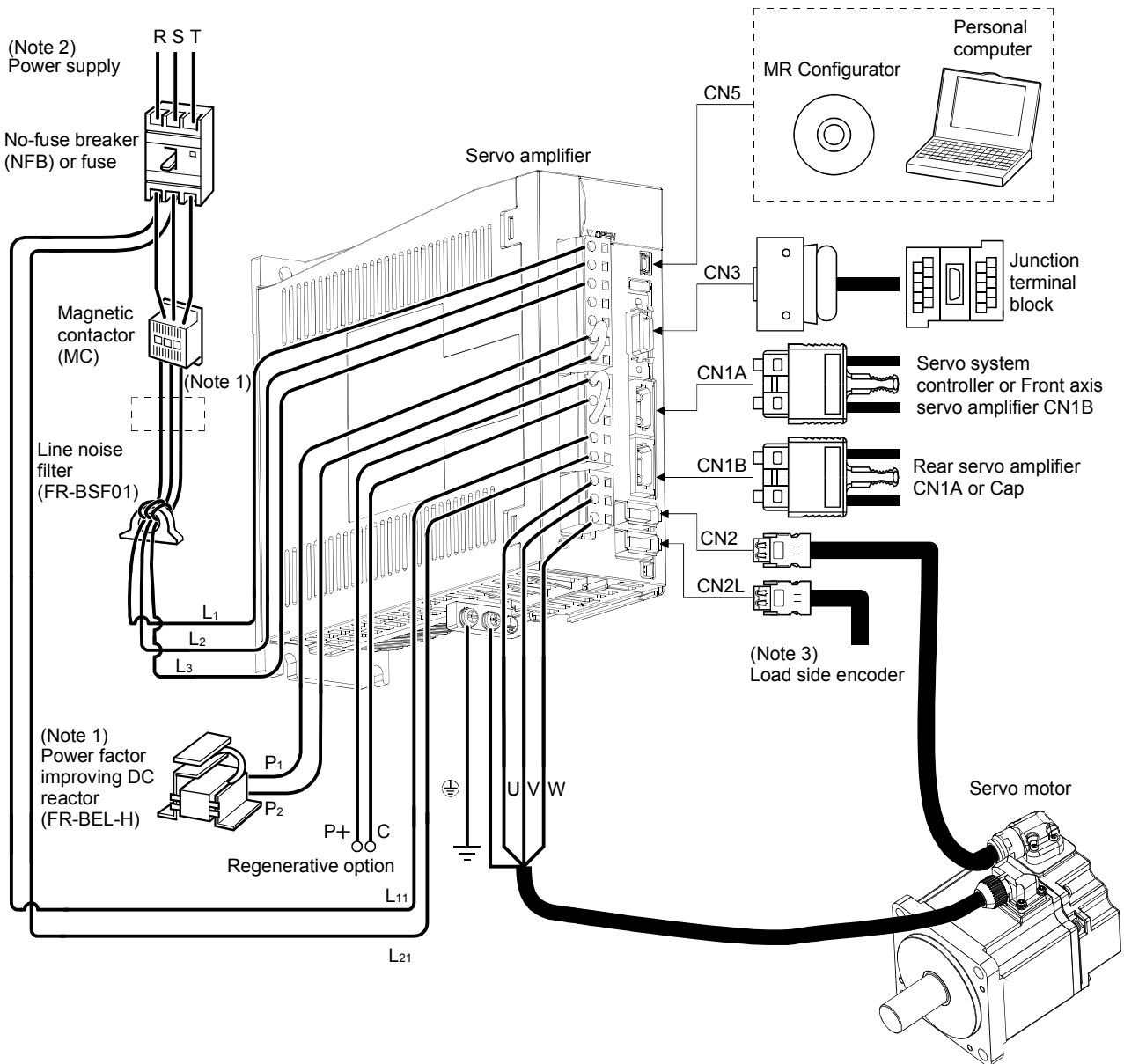

Note 1. The power factor improving AC reactor can also be used. In this case, the power factor improving DC reactor cannot be used.

When not using the power factor improving DC reactor, short P₁ and P₂.

2. Refer to section 1.3 for the power supply specification.

3. For the configuration of the ABZ-phase pulse train interface or serial communication specification linear encoder/rotary encoder, refer to section 1.10.

1. FUNCTIONS AND CONFIGURATION

(3) MR-J3-200B(4)-RJ006

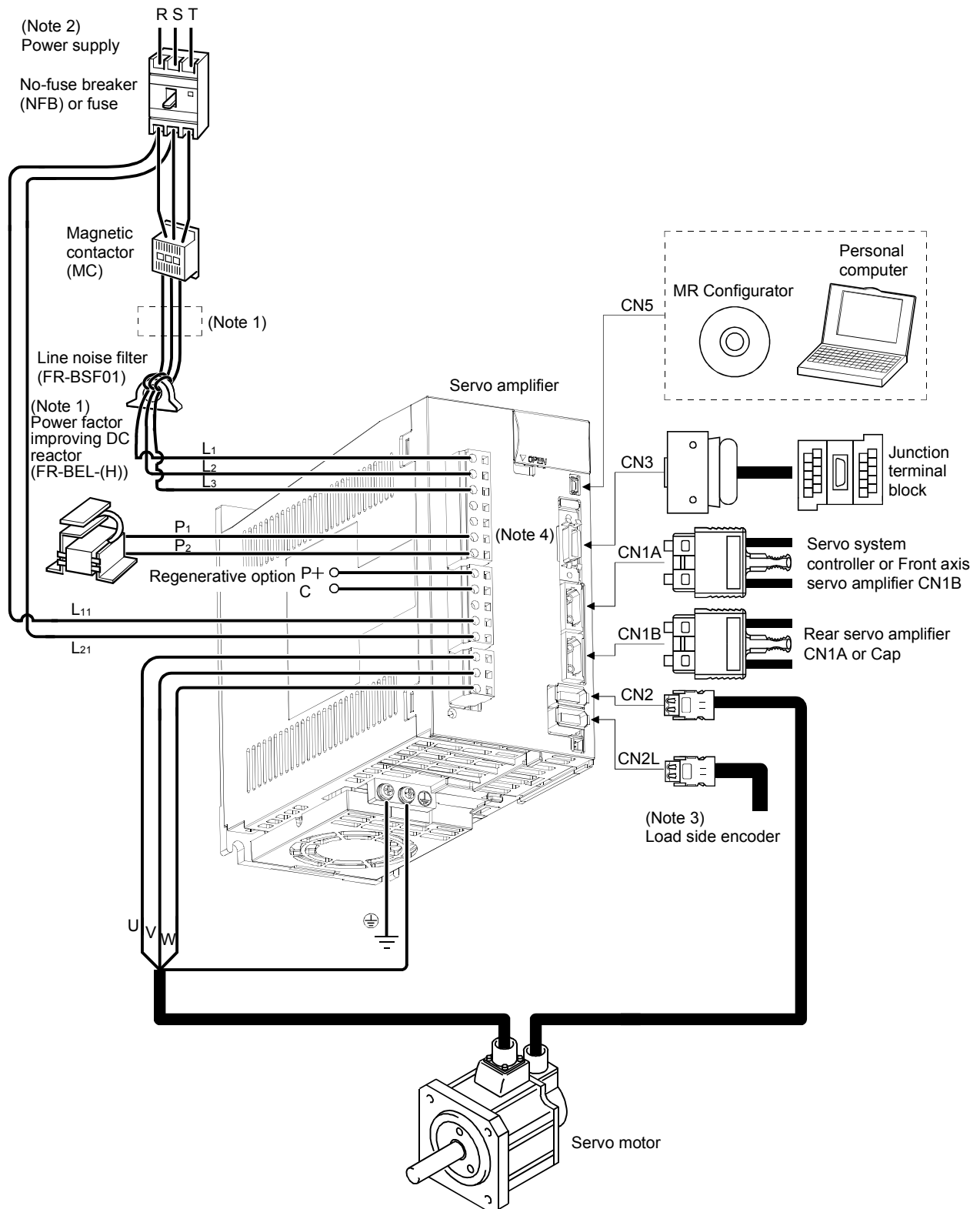

- Note 1. The power factor improving AC reactor can also be used. In this case, the power factor improving DC reactor cannot be used. When not using the power factor improving DC reactor, short P1 and P2.
2. Refer to section 1.3 for the power supply specification.
3. For the configuration of the ABZ-phase pulse train interface or serial communication specification linear encoder/rotary encoder, refer to section 1.10.
4. Connectors (CNP1, CNP2, and CNP3) and appearance of MR-J3-200B-RJ006 servo amplifier have been changed from April 2008 production. For existing servo amplifier, refer to appendix 4.

1. FUNCTIONS AND CONFIGURATION

(4) MR-J3-350B-RJ006

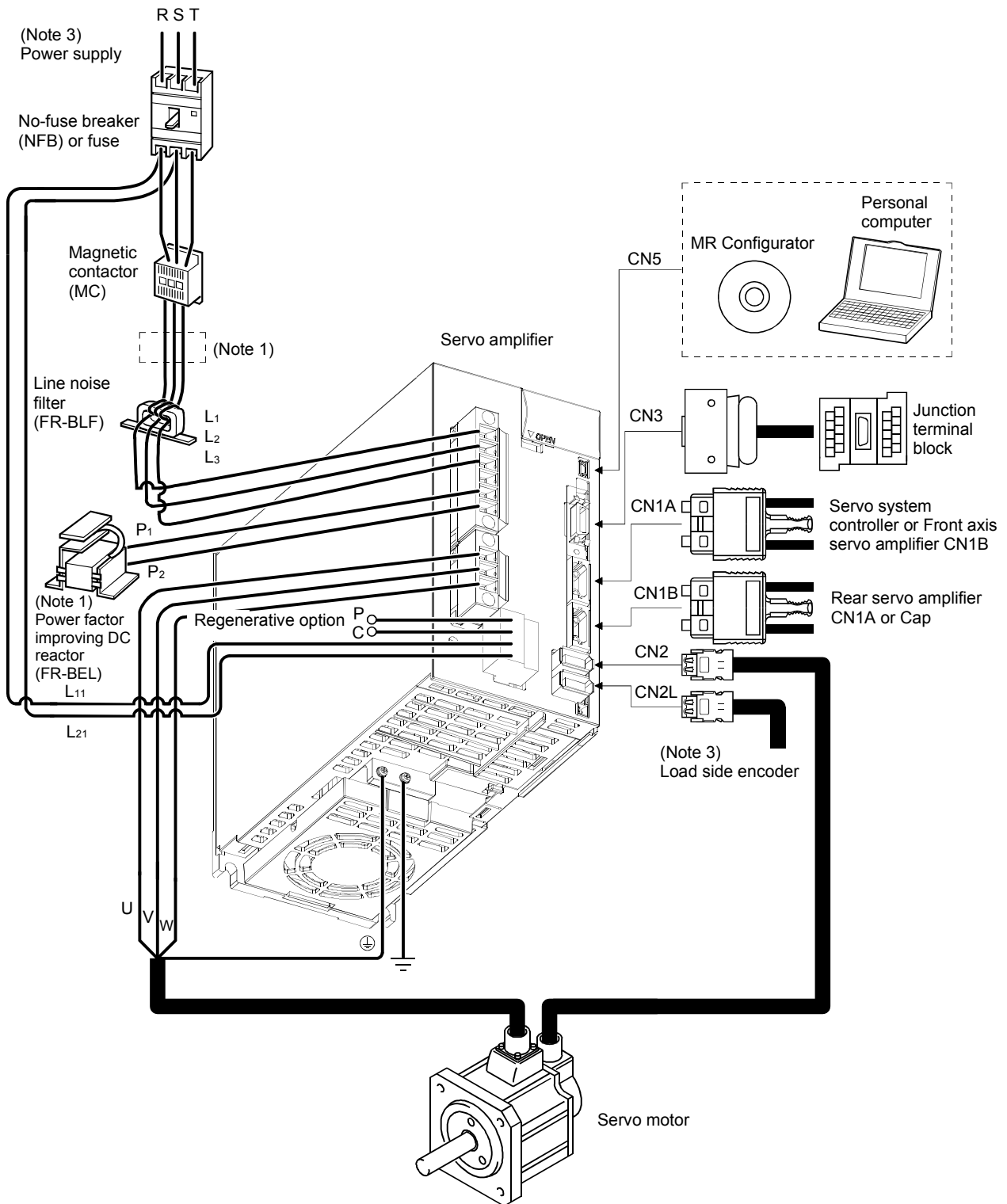

- Note 1. The power factor improving AC reactor can also be used. In this case, the power factor improving DC reactor cannot be used. When not using the power factor improving DC reactor, short P₁ and P₂.
- For the configuration of the ABZ-phase pulse train interface or serial communication specification linear encoder/rotary encoder, refer to section 1.10.
 - Refer to section 1.3 for the power supply specification.

1. FUNCTIONS AND CONFIGURATION

(5) MR-J3-350B4-RJ006 • MR-J3-500B(4)-RJ006

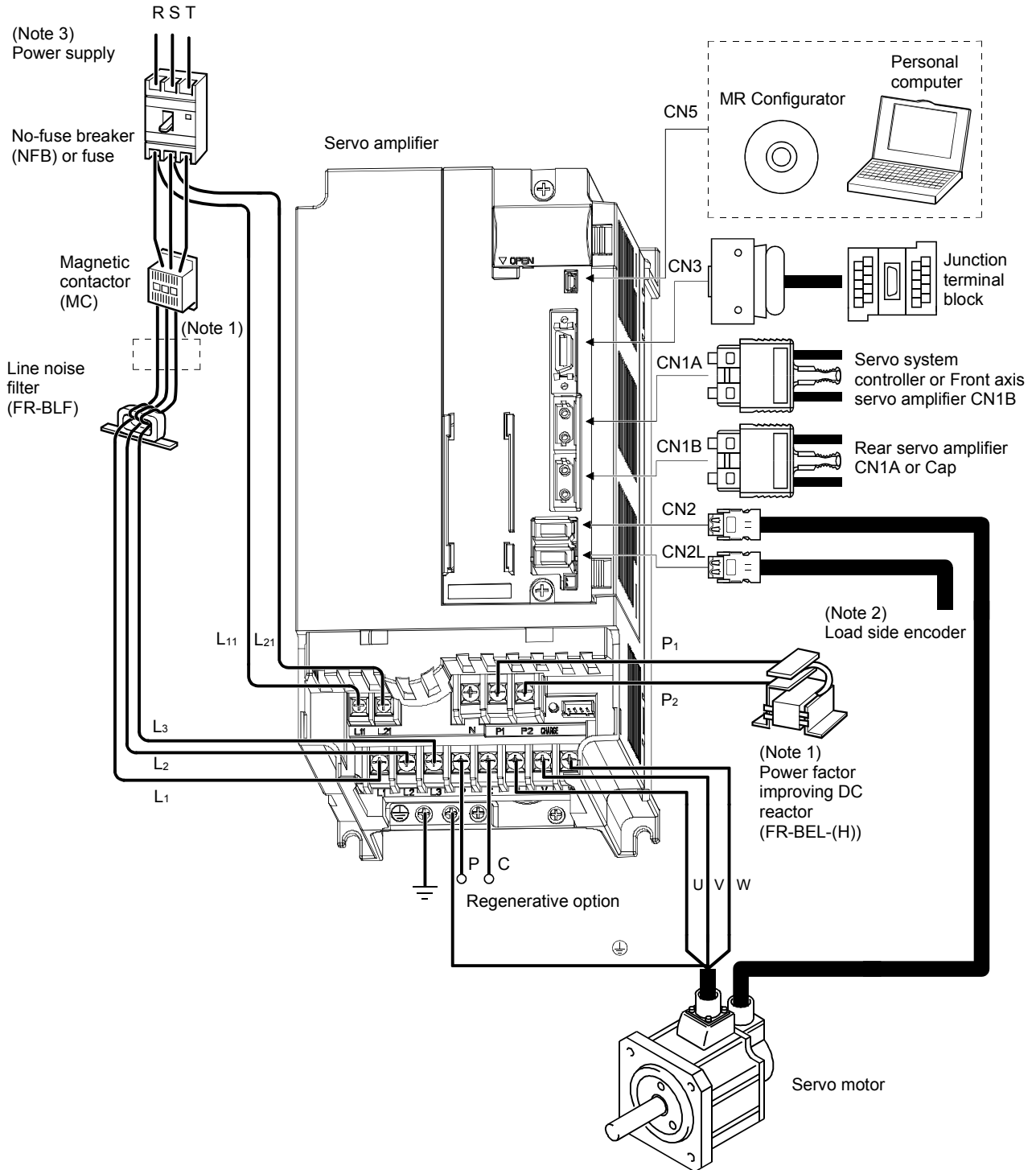

Note 1. The power factor improving AC reactor can also be used. In this case, the power factor improving DC reactor cannot be used.

When not using the power factor improving DC reactor, short P₁ and P₂.

2. For the configuration of the ABZ-phase pulse train interface or serial communication specification linear encoder/rotary encoder, refer to section 1.10.

3. Refer to section 1.3 for the power supply specification.

1. FUNCTIONS AND CONFIGURATION

(6) MR-J3-700B(4)-RJ006

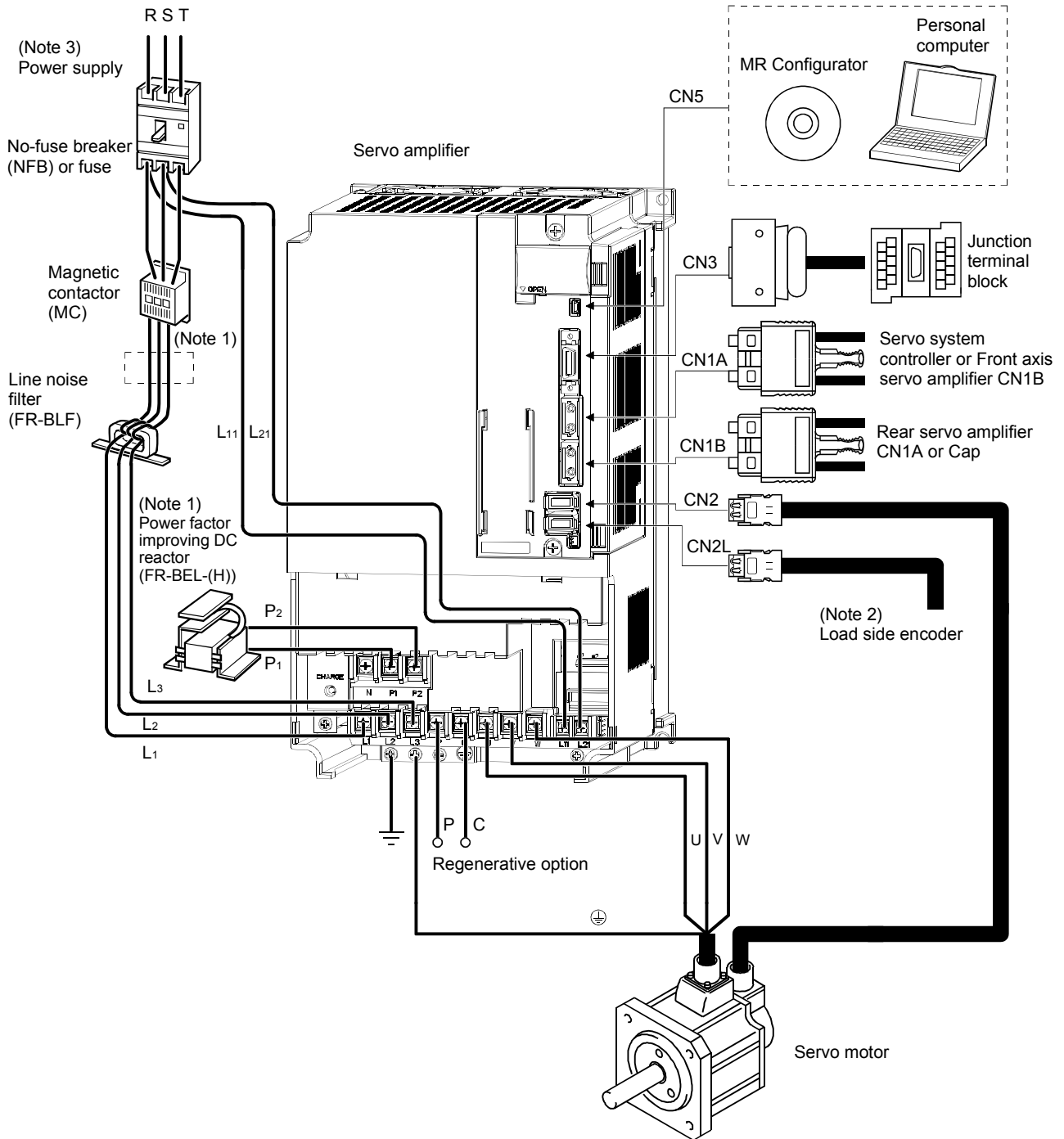

Note 1. The power factor improving AC reactor can also be used. In this case, the power factor improving DC reactor cannot be used.

When not using the power factor improving DC reactor, short P₁ and P₂.

2. For the configuration of the ABZ-phase pulse train interface or serial communication specification linear encoder/rotary encoder, refer to section 1.10.

3. Refer to section 1.3 for the power supply specification.

1. FUNCTIONS AND CONFIGURATION

(7) MR-J3-11KB(4)-RJ006 to MR-J3-22KB(4)-RJ006

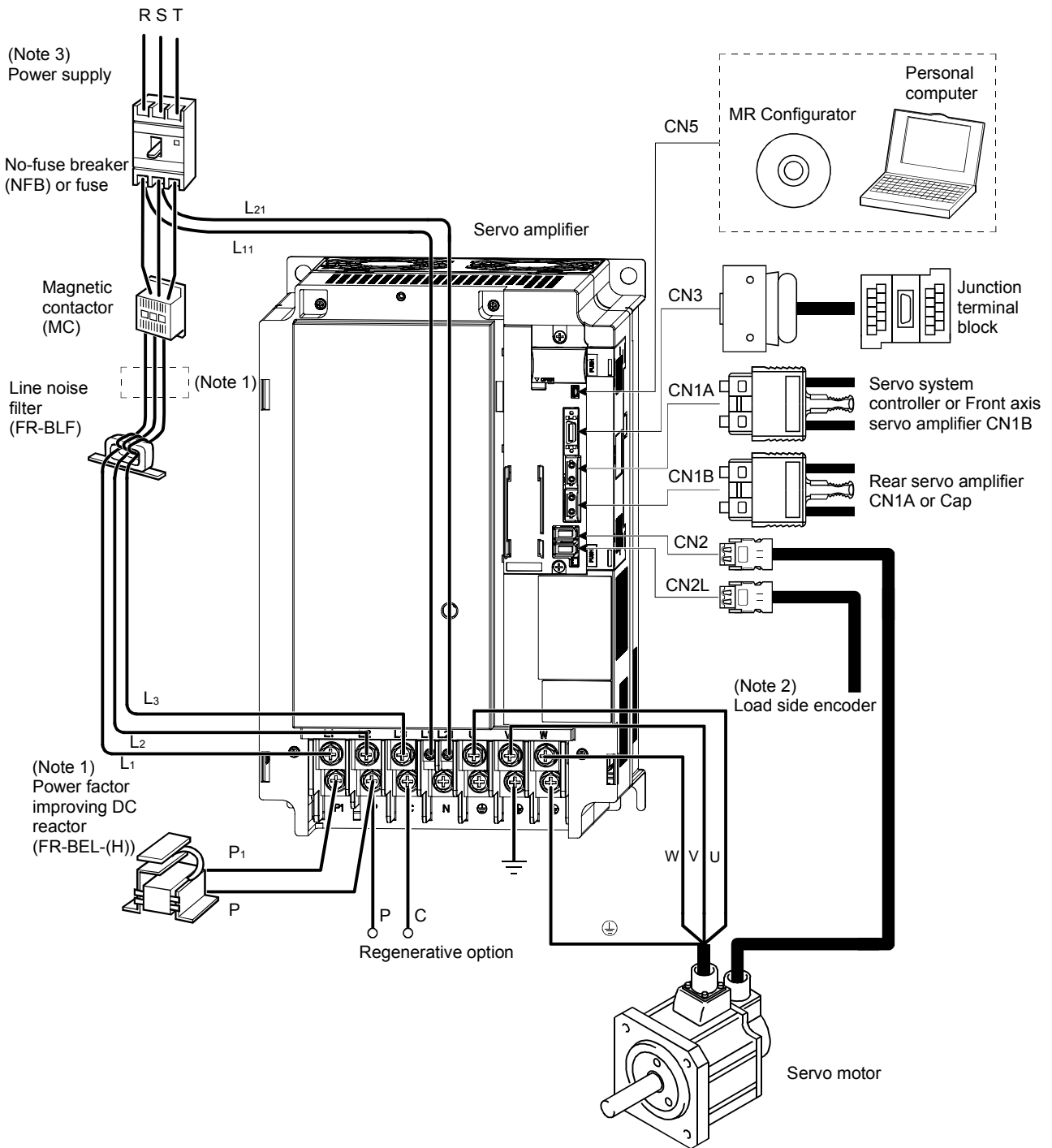

Note 1. The power factor improving AC reactor can also be used. In this case, the power factor improving DC reactor cannot be used.

When not using the power factor improving DC reactor, short P₁ and P.

2. For the configuration of the ABZ-phase pulse train interface or serial communication specification linear encoder/rotary encoder, refer to section 1.10.

3. Refer to section 1.3 for the power supply specification.

1. FUNCTIONS AND CONFIGURATION

1.10 System configuration

POINT	<ul style="list-style-type: none"> For details of configuration with auxiliary equipments, refer to the MR-J3-□B Servo Amplifier Instruction Manual.
-------	---

(1) For a linear encoder

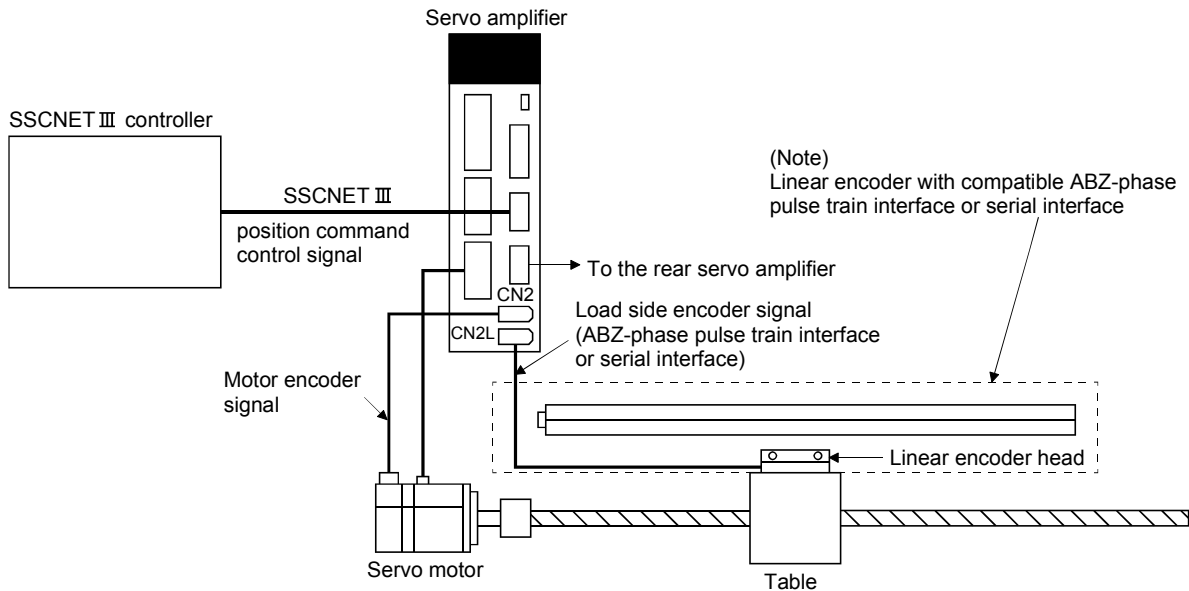

Note. Applicable for the absolute position detection system when an absolute position linear encoder is used.
In that case, a battery (MR-J3BAT) is not required.

(2) For a rotary encoder

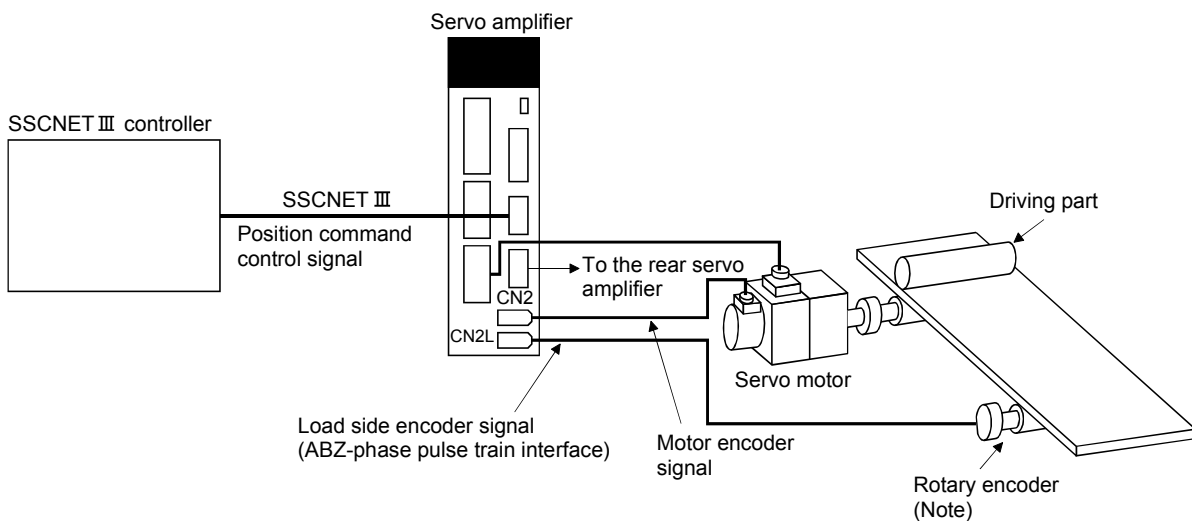

Note. Not applicable for the absolute position detection system.
For the ABZ-phase differential output rotary encoder, refer to section 3.3.

2. SIGNALS AND WIRING

2. SIGNALS AND WIRING

WARNING

- Any person who is involved in wiring should be fully competent to do the work.
- Before wiring, turn off the power and wait for 15 minutes or more until the charge lamp turns off. Then, confirm that the voltage between P(+) and N(−) is safe with a voltage tester and others. Otherwise, an electric shock may occur. In addition, always confirm from the front of the servo amplifier whether the charge lamp is off or not.
- Ground the servo amplifier and the servo motor securely.
- Do not attempt to wire the servo amplifier and servo motor until they have been installed. Otherwise, you may get an electric shock.
- The cables should not be damaged, stressed excessively, loaded heavily, or pinched. Otherwise, you may get an electric shock.

CAUTION

- Wire the equipment correctly and securely. Otherwise, the servo motor may operate unexpected, resulting in injury.
- Connect cables to correct terminals to prevent a burst, fault, etc.
- Ensure that polarity (+, −) is correct. Otherwise, a burst, damage, etc. may occur.
- The surge absorbing diode installed on the DC output signal relay must be wired in the specified direction. Otherwise, the emergency stop and other protective circuits may not operate.

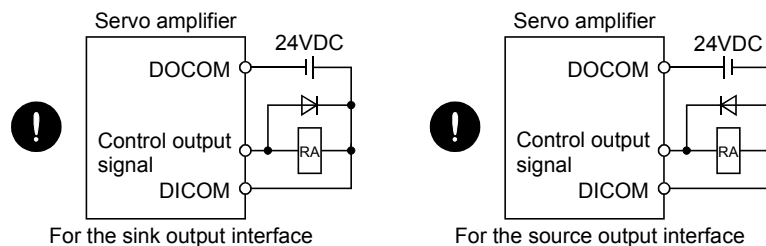

- Use a noise filter, etc. to minimize the influence of electromagnetic interference, which may be given to electronic equipment used near the servo amplifier.
- Do not install a power capacitor, surge suppressor or radio noise filter (FR-BIF-(H) option) with the power line of the servo motor.
- When using the regenerative resistor, switch power off with the alarm signal. Otherwise, a transistor fault or the like may overheat the regenerative resistor, causing a fire.
- Do not modify the equipment.
- During power-on, do not open or close the motor power line. Otherwise, a malfunction or faulty may occur.

2. SIGNALS AND WIRING

2.1 Precautions for this chapter

The following items are not described in this chapter. Since these descriptions are the same as those of MR-J3-□B Servo Amplifier, refer to the MR-J3-□B Servo Amplifier Instruction Manual.

Item	MR-J3-□B Servo Amplifier Instruction Manual
Explanation of power supply system	Section 3.3
Signal (device) explanations	Section 3.5
Alarm occurrence timing chart	Section 3.6
Interfaces	Section 3.7 (excluding the internal connection diagram)
SSCNET III cable connection	Section 3.9
Connection of servo amplifier and servo motor	Section 3.10
Servo motor with an electromagnetic brake	Section 3.11
Grounding	Section 3.12
Control axis selection	Section 3.13

2.2 Input power supply circuit



CAUTION

- Always connect a magnetic contactor between the main circuit power supply and L₁, L₂, and L₃ of the servo amplifier, and configure the wiring to be able to shut down the power supply on the side of the servo amplifier's power supply. If a magnetic contactor is not connected, continuous flow of a large current may cause a fire when the servo amplifier malfunctions.
- Use the trouble signal to switch main circuit power supply off. Otherwise, a regenerative transistor fault or the like may overheat the regenerative resistor, causing a fire.
- During power-on, do not open or close the motor power line. Otherwise, a malfunction or faulty may occur.

POINT

- Even if alarm has occurred, do not switch off the control circuit power supply. When the control circuit power supply has been switched off, optical module does not operate, and optical transmission of SSCNETIII communication is interrupted. Therefore, the servo amplifier on the rear axis displays "AA" at the indicator and turns into base circuit shut-off. The servo amplifier stops with starting dynamic brake.
- For details of each signal, refer to section 3.3 of the MR-J3-□B Servo Amplifier Instruction Manual.
- During power-on, do not open or close the motor power line. Otherwise, a malfunction or faulty may occur.

Wire the power supply/main circuit as shown below so that power is shut off and the servo-on command turned off as soon as an alarm occurs, a servo forced stop is made valid, or a controller forced stop is made valid. A no-fuse breaker (NFB) must be used with the input cables of the main circuit power supply.

2. SIGNALS AND WIRING

(1) For 3-phase 200 to 230VAC power supply to MR-J3-10B-RJ006 to MR-J3-350B-RJ006

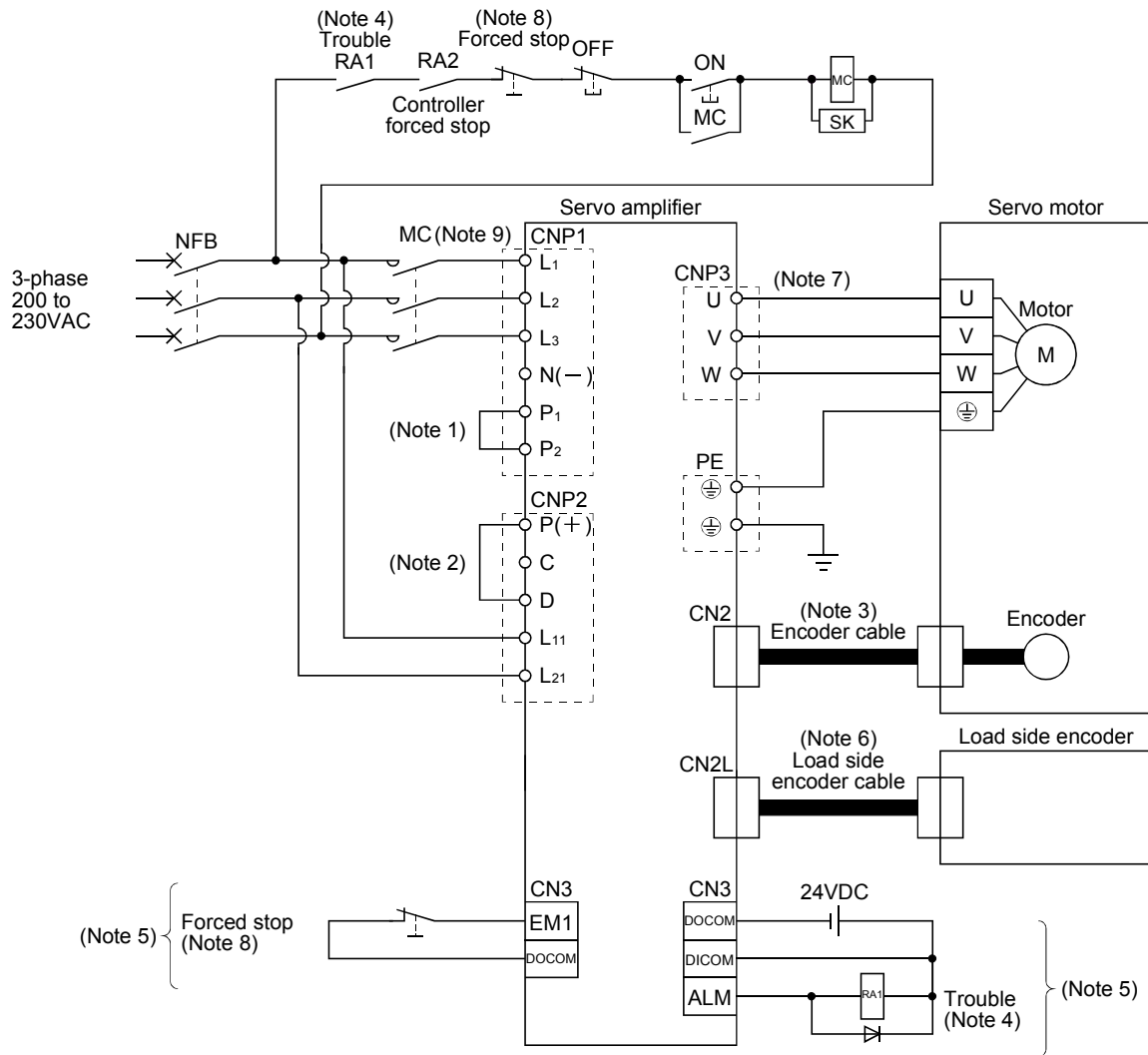

- Note 1. Always connect P₁ and P₂. (Factory-wired.) When using the power factor improving DC reactor, refer to chapter 11 of the MR-J3-□B Servo Amplifier Instruction Manual. Use only one of power factor improving DC reactor or power factor improving AC reactor.
- Note 2. Always connect P(+) and D. (Factory-wired.) When using the regenerative option, refer to chapter 11 of the MR-J3-□B Servo Amplifier Instruction Manual.
- Note 3. For the encoder cable, use of the option cable is recommended. Refer to chapter 11 of the MR-J3-□B Servo Amplifier Instruction Manual for selection of the cable.
- Note 4. If deactivating output of trouble (ALM) with parameter change, configure up the power supply circuit which switches off the magnetic contactor after detection of alarm occurrence on the controller side.
- Note 5. For the sink I/O interface. For the source I/O interface, refer to section 3.7.3 of the MR-J3-□B Servo Amplifier Instruction Manual.
- Note 6. For connection of the servo amplifier and linear encoder, a cable compatible with the linear encoder of a manufacturer to be used is required. For selection of the cable, refer to chapter 3.
- Note 7. For details of connection of the servo amplifier and servo motor, refer to section 3.10 of the MR-J3-□B Servo Amplifier Instruction Manual.
- Note 8. Configure the circuit to shut down the main circuit power supply simultaneously with the turn off of forced stop (EM1) using the external sequence.
- Note 9. Be sure to use a magnetic contactor (MC) with an operation delay time of 80ms or less. The operation delay time is the time interval between current being applied to the magnetic coil until closure of contacts.

2. SIGNALS AND WIRING

(3) For MR-J3-10B1-RJ006 to MR-J3-40B1-RJ006

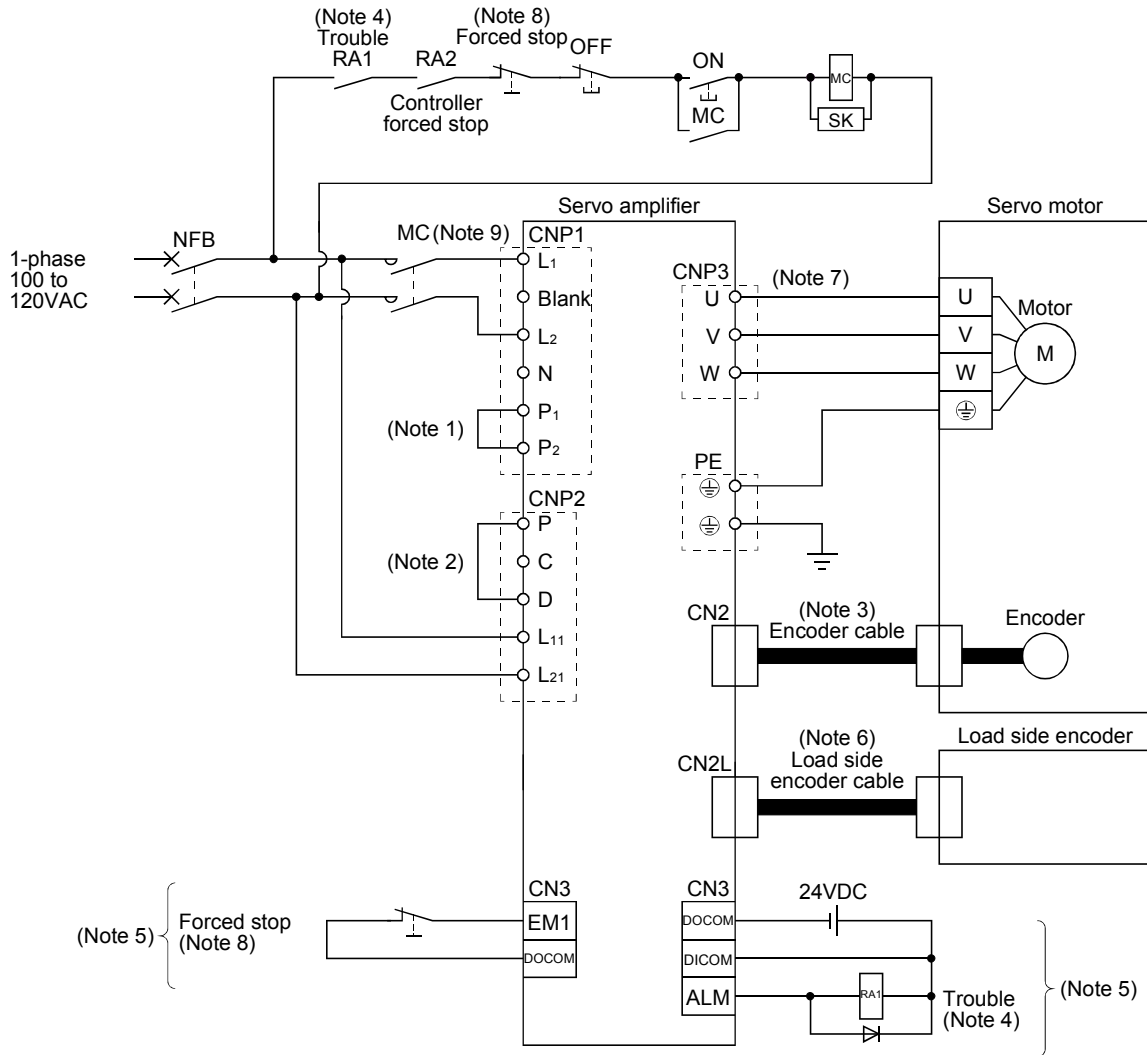

- Note 1. Always connect P₁ and P₂. (Factory-wired.) The power factor improving DC reactor cannot be used.
- Note 2. Always connect P and D. (Factory-wired.) When using the regenerative option, refer to chapter 11 of the MR-J3-□B Servo Amplifier Instruction Manual.
- Note 3. For the encoder cable, use of the option cable is recommended. Refer to chapter 11 of the MR-J3-□B Servo Amplifier Instruction Manual for selection of the cable.
- Note 4. If deactivating output of trouble (ALM) with parameter change, configure up the power supply circuit which switches off the magnetic contactor after detection of alarm occurrence on the controller side.
- Note 5. For the sink I/O interface. For the source I/O interface, refer to section 3.7.3 of the MR-J3-□B Servo Amplifier Instruction Manual.
- Note 6. For connection of the servo amplifier and linear encoder, a cable compatible with the linear encoder of a manufacturer to be used is required. For selection of the cable, refer to chapter 3.
- Note 7. For details of connection of the servo amplifier and servo motor, refer to section 3.10 of the MR-J3-□B Servo Amplifier Instruction Manual.
- Note 8. Configure the circuit to shut down the main circuit power supply simultaneously with the turn off of forced stop (EM1) using the external sequence.
- Note 9. Be sure to use a magnetic contactor (MC) with an operation delay time of 80ms or less. The operation delay time is the time interval between current being applied to the magnetic coil until closure of contacts.

2. SIGNALS AND WIRING

(4) MR-J3-60B4-RJ006 to MR-J3-200B4-RJ006

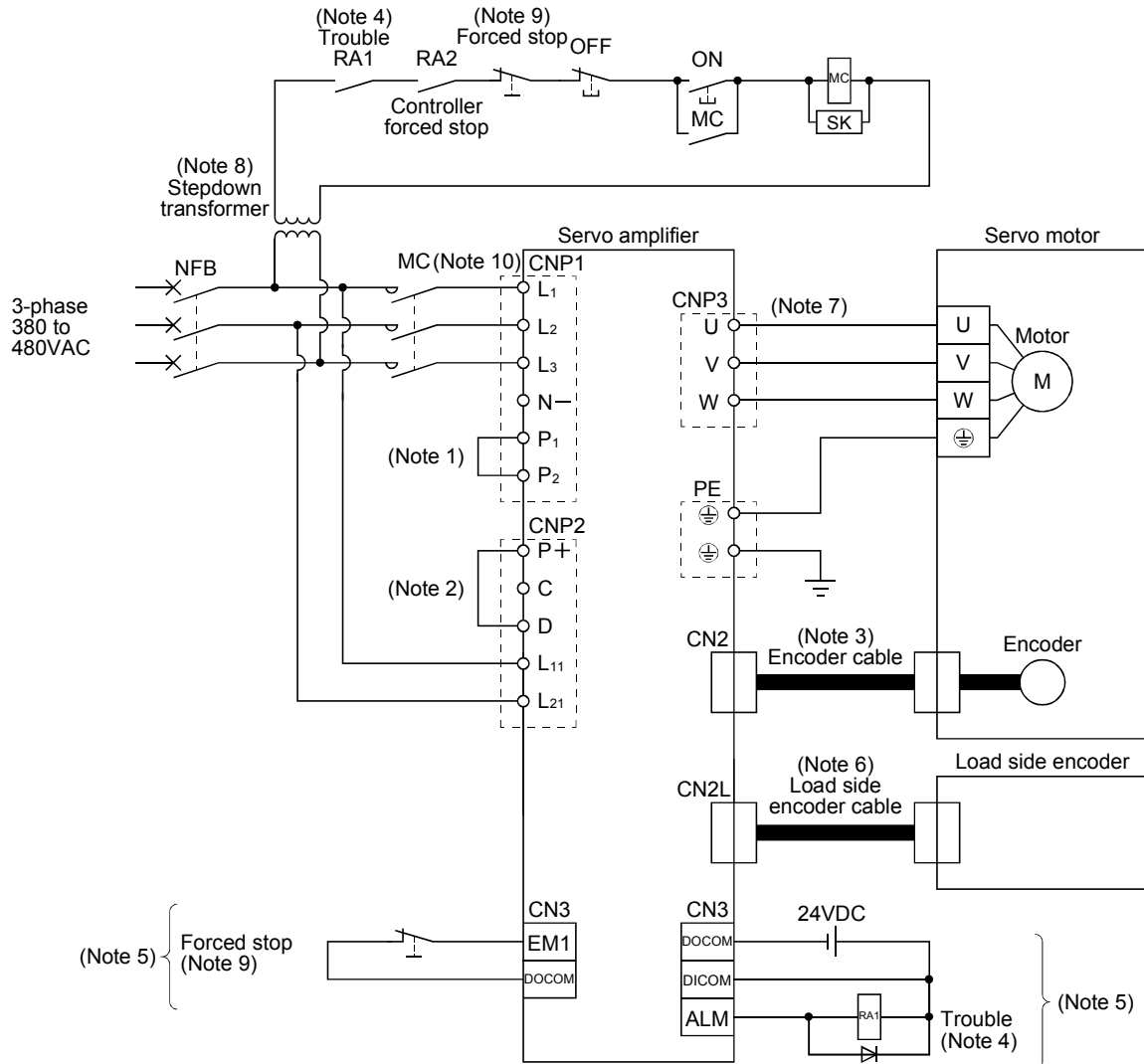

Note 1. Always connect P₁ and P₂. (Factory-wired.) When using the power factor improving DC reactor, refer to chapter 11 of the MR-J3-□B Servo Amplifier Instruction Manual. Use only one of power factor improving DC reactor or power factor improving AC reactor.

2. Always connect P and D. (Factory-wired.) When using the regenerative option, refer to chapter 11 of the MR-J3-□B Servo Amplifier Instruction Manual.

3. For the encoder cable, use of the option cable is recommended. Refer to chapter 11 of the MR-J3-□B Servo Amplifier Instruction Manual for selection of the cable.

4. If deactivating output of trouble (ALM) with parameter change, configure up the power supply circuit which switches off the magnetic contactor after detection of alarm occurrence on the controller side.

5. For the sink I/O interface. For the source I/O interface, refer to section 3.7.3 of the MR-J3-□B Servo Amplifier Instruction Manual.

6. For connection of the servo amplifier and linear encoder, a cable compatible with the linear encoder of a manufacturer to be used is required. For selection of the cable, refer to chapter 3.

7. For details of connection of the servo amplifier and servo motor, refer to section 3.10 of the MR-J3-□B Servo Amplifier Instruction Manual.

8. Stepdown transformer is required for coil voltage of magnetic contactor more than 200V class.

9. Configure the circuit to shut down the main circuit power supply simultaneously with the turn off of forced stop (EM1) using the external sequence.

10. Be sure to use a magnetic contactor (MC) with an operation delay time of 80ms or less. The operation delay time is the time interval between current being applied to the magnetic coil until closure of contacts.

2. SIGNALS AND WIRING

(5) MR-J3-500B-RJ006 • MR-J3-700B-RJ006

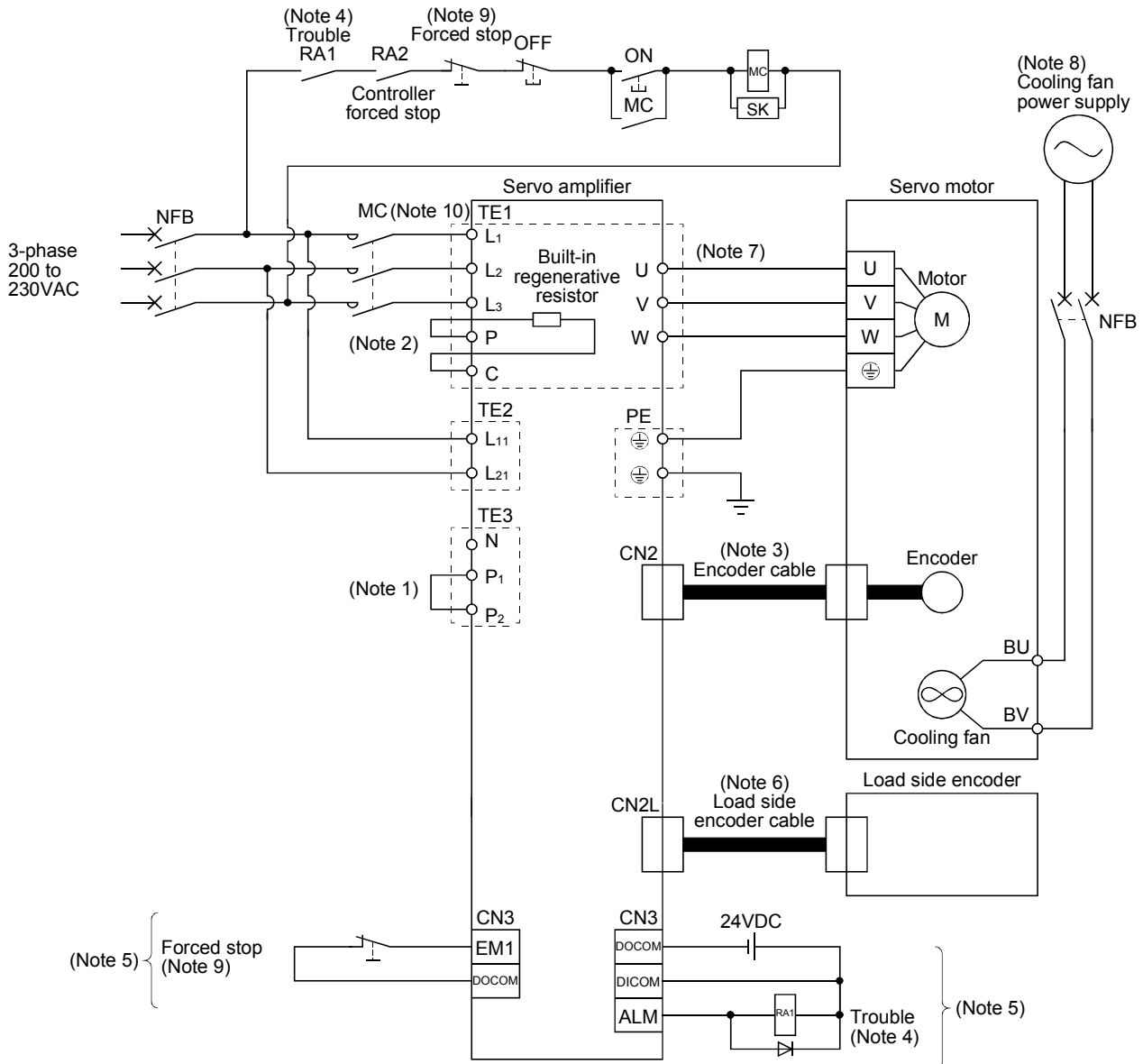

Note 1. Always connect P₁ and P₂. (Factory-wired.) When using the power factor improving DC reactor, refer to chapter 11 of the MR-J3-□B Servo Amplifier Instruction Manual. Use only one of power factor improving DC reactor or power factor improving AC reactor.

Note 2. When using the regenerative option, refer to chapter 11 of the MR-J3-□B Servo Amplifier Instruction Manual.

Note 3. For the encoder cable, use of the option cable is recommended. Refer to chapter 11 of the MR-J3-□B Servo Amplifier Instruction Manual for selection of the cable.

Note 4. If deactivating output of trouble (ALM) with parameter change, configure up the power supply circuit which switches off the magnetic contactor after detection of alarm occurrence on the controller side.

Note 5. For the sink I/O interface. For the source I/O interface, refer to section 3.7.3 of the MR-J3-□B Servo Amplifier Instruction Manual.

Note 6. For connection of the servo amplifier and linear encoder, a cable compatible with the linear encoder of a manufacturer to be used is required. For selection of the cable, refer to chapter 3.

Note 7. For details of connection of the servo amplifier and servo motor, refer to section 3.10 of the MR-J3-□B Servo Amplifier Instruction Manual.

Note 8. A cooling fan is attached to the HA-LP601 and the HA-LP701M servo motors. For power supply specification of the cooling fan, refer to section 3.10 of the MR-J3-□B Servo Amplifier Instruction Manual.

Note 9. Configure the circuit to shut down the main circuit power supply simultaneously with the turn off of forced stop (EM1) using the external sequence.

Note 10. Be sure to use a magnetic contactor (MC) with an operation delay time of 80ms or less. The operation delay time is the time interval between current being applied to the magnetic coil until closure of contacts.

2. SIGNALS AND WIRING

(6) MR-J3-350B4-RJ006 to MR-J3-700B4-RJ006

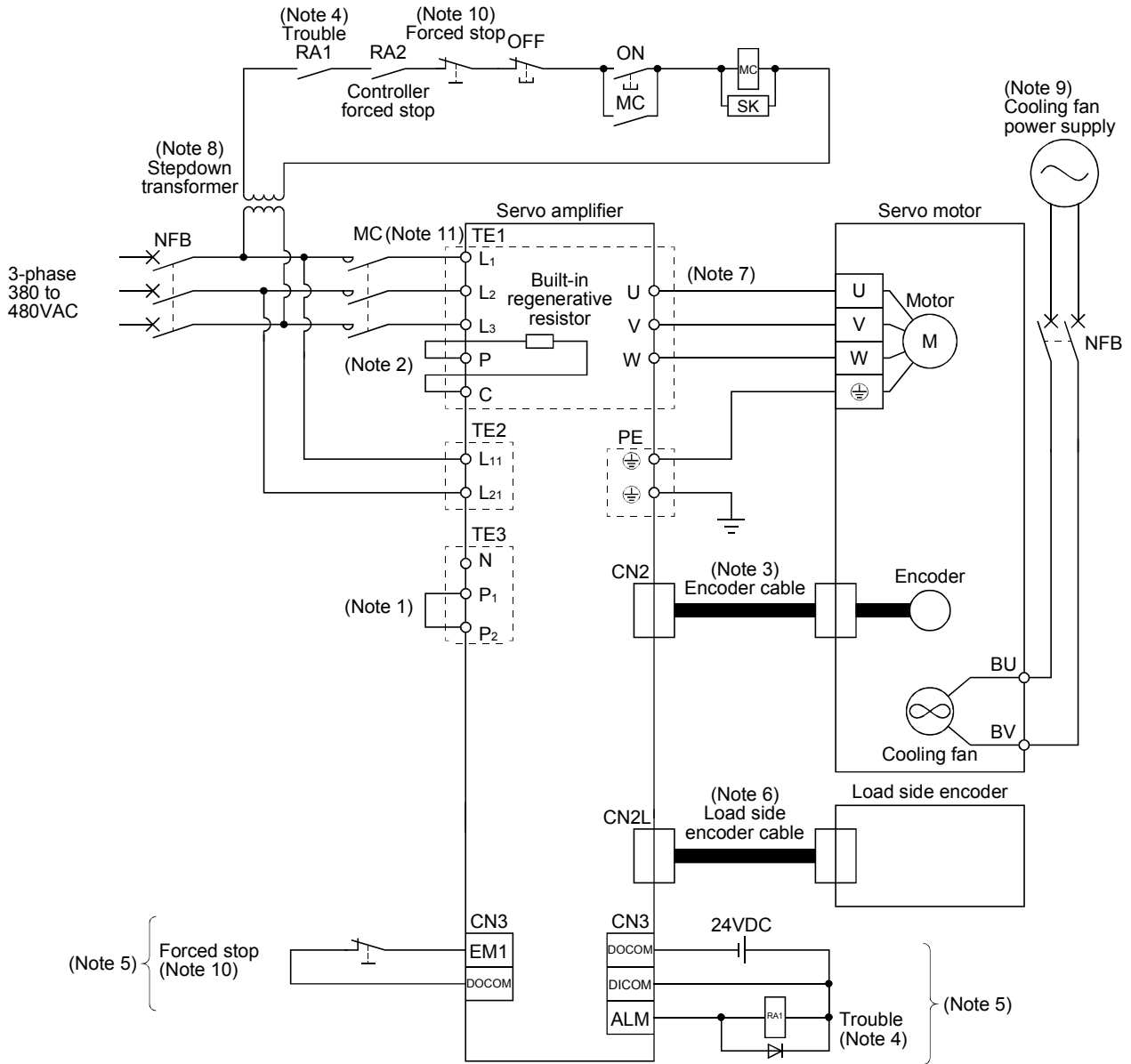

2. SIGNALS AND WIRING

- Note 1. Always connect P₁ and P₂. (Factory-wired.) When using the power factor improving DC reactor, refer to chapter 11 of the MR-J3-□B Servo Amplifier Instruction Manual. Use only one of power factor improving DC reactor or power factor improving AC reactor.
2. When using the regenerative option, refer to chapter 11 of the MR-J3-□B Servo Amplifier Instruction Manual.
 3. For the encoder cable, use of the option cable is recommended. Refer to chapter 11 of the MR-J3-□B Servo Amplifier Instruction Manual for selection of the cable.
 4. If deactivating output of trouble (ALM) with parameter change, configure up the power supply circuit which switches off the magnetic contactor after detection of alarm occurrence on the controller side.
 5. For the sink I/O interface. For the source I/O interface, refer to section 3.7.3 of the MR-J3-□B Servo Amplifier Instruction Manual.
 6. For connection of the servo amplifier and linear encoder, a cable compatible with the linear encoder of a manufacturer to be used is required. For selection of the cable, refer to chapter 3.
 7. For details of connection of the servo amplifier and servo motor, refer to section 3.10 of the MR-J3-□B Servo Amplifier Instruction Manual.
 8. Stepdown transformer is required for coil voltage of magnetic contactor more than 200V class.
 9. A cooling fan is attached to the HA-LP6014 and the HA-LP701M4 servo motors. For power supply specification of the cooling fan, refer to section 3.10 of the MR-J3-□B Servo Amplifier Instruction Manual.
 10. Configure the circuit to shut down the main circuit power supply simultaneously with the turn off of forced stop (EM1) using the external sequence.
 11. Be sure to use a magnetic contactor (MC) with an operation delay time of 80ms or less. The operation delay time is the time interval between current being applied to the magnetic coil until closure of contacts.

2. SIGNALS AND WIRING

- Note 1. Always connect P₁ and P. (Factory-wired.) When using the power factor improving DC reactor, refer to chapter 11 of the MR-J3-□B Servo Amplifier Instruction Manual. Use only one of power factor improving DC reactor or power factor improving AC reactor.
2. Connect the regenerative resistor. When using a regenerative option for the MR-J3-□B-RJ006 servo amplifier, refer to chapter 11 of the MR-J3-□B-RJ006 Servo Amplifier Instruction Manual.
The regenerative resistor is not attached to the servo amplifiers of MR-J3-11KB(4)-RZ006 to MR-J3-22KB(4)-RZ006 as those of MR-J3-11KB(4)-PX to MR-J3-22KB(4)-PX. Therefore, when using the regenerative option for MR-J3-□B-RZ006 servo amplifier, refer to section 11.2 (4) (d) MR-J3-11KB(4)-PX to MR-J3-22KB(4)-PX (when using the regenerative options) of the MR-J3-□B Servo Amplifier Instruction Manual.
 3. The use of optional cable is recommended for the connection between the servo amplifier and servo motor. For the selection of the cable, refer to chapter 11 of the MR-J3-□B Servo Amplifier Instruction Manual.
 4. If deactivating output of trouble (ALM) with parameter change, configure up the power supply circuit which switches off the magnetic contactor after detection of alarm occurrence on the controller side.
 5. For the sink I/O interface. For the source I/O interface, refer to section 3.7.3 of the MR-J3-□B Servo Amplifier Instruction Manual.
 6. For connection of the servo amplifier and linear encoder, a cable compatible with the linear encoder of a manufacturer to be used is required. For selection of the cable, refer to chapter 3.
 7. For details of connection of the servo amplifier and servo motor, refer to section 3.10 of the MR-J3-□B Servo Amplifier Instruction Manual.
 8. Cooling fan power supply of the HA-LP11K2 servo motor is 1-phase. Power supply specification of the cooling fan is different from that of the servo amplifier. Therefore, separate power supply is required.
 9. Configure the circuit to shut down the main circuit power supply simultaneously with the turn off of forced stop (EM1) using the external sequence.
 10. Be sure to use a magnetic contactor (MC) with an operation delay time of 80ms or less. The operation delay time is the time interval between current being applied to the magnetic coil until closure of contacts.

2. SIGNALS AND WIRING

(8) MR-J3-11KB4-RJ006 to MR-J3-22KB4-RJ006

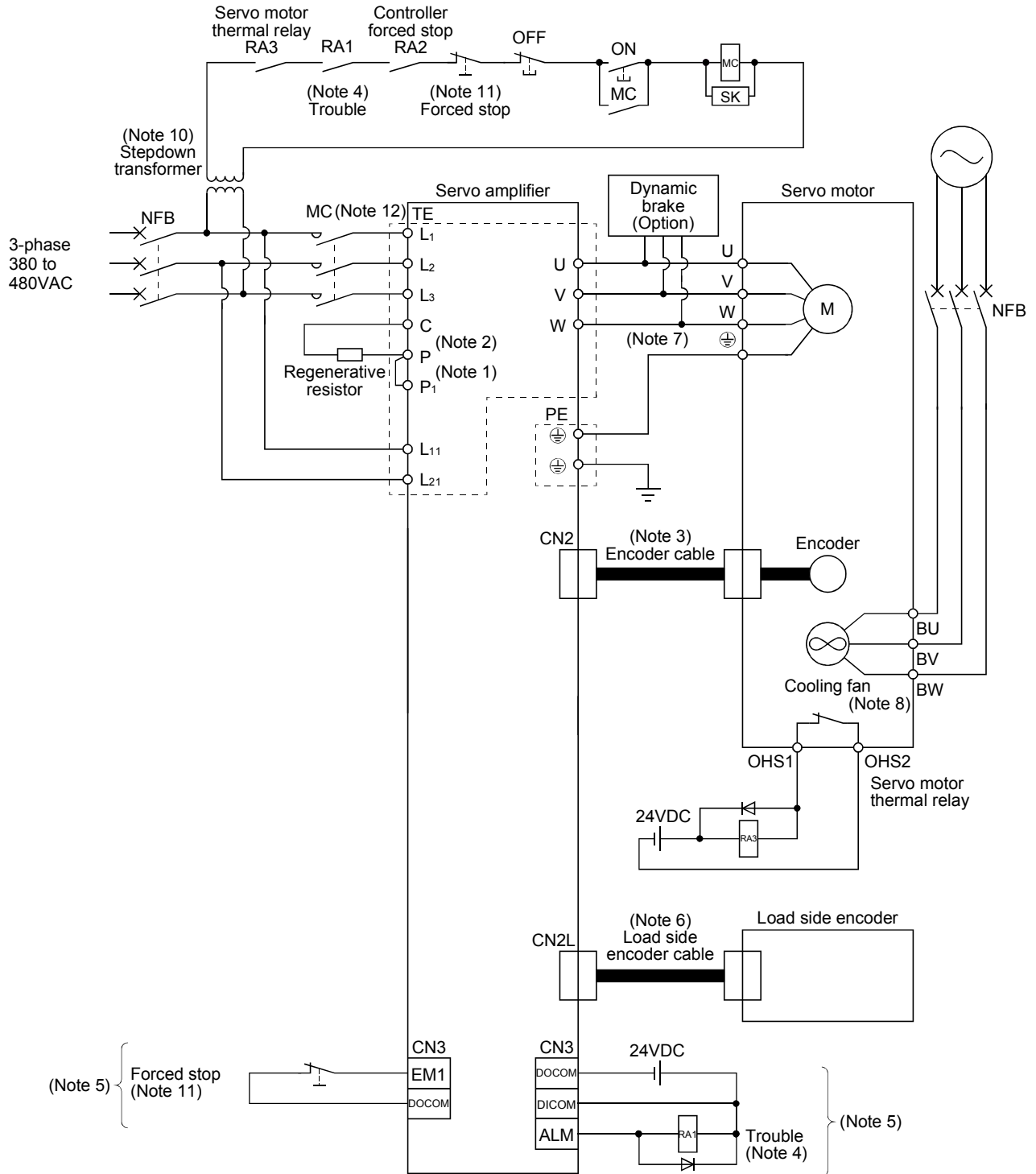

2. SIGNALS AND WIRING

- Note 1. Always connect P₁ and P. (Factory-wired.) When using the power factor improving DC reactor, refer to chapter 11 of the MR-J3-□B Servo Amplifier Instruction Manual. Use only one of power factor improving DC reactor or power factor improving AC reactor.
2. Connect the regenerative resistor. When using a regenerative option for the MR-J3-□B-RJ006 servo amplifier, refer to chapter 11 of the MR-J3-□B-RJ006 Servo Amplifier Instruction Manual.
The regenerative resistor is not attached to the servo amplifiers of MR-J3-11KB(4)-RZ006 to MR-J3-22KB(4)-RZ006 as those of MR-J3-11KB(4)-PX to MR-J3-22KB(4)-PX. Therefore, when using the regenerative option for MR-J3-□B-RZ006 servo amplifier, refer to section 11.2 (4) (d) MR-J3-11KB(4)-PX to MR-J3-22KB(4)-PX (when using the regenerative options) of the MR-J3-□B Servo Amplifier Instruction Manual.
 3. The use of optional cable is recommended for the connection between the servo amplifier and servo motor. For the selection of the cable, refer to chapter 11 of the MR-J3-□B Servo Amplifier Instruction Manual.
 4. If deactivating output of trouble (ALM) with parameter change, configure up the power supply circuit which switches off the magnetic contactor after detection of alarm occurrence on the controller side.
 5. For the sink I/O interface. For the source I/O interface, refer to section 3.7.3 of the MR-J3-□B Servo Amplifier Instruction Manual.
 6. For connection of the servo amplifier and linear encoder, a cable compatible with the linear encoder of a manufacturer to be used is required. For selection of the cable, refer to chapter 3.
 7. For details of connection of the servo amplifier and servo motor, refer to section 3.10 of the MR-J3-□B Servo Amplifier Instruction Manual.
 8. Servo amplifiers does not have BW when the cooling fan power supply is 1-phase.
 9. For the cooling fan power supply, refer to (3) (b) in section 3.10 of the MR-J3-□B Servo Amplifier Instruction Manual.
 10. Stepdown transformer is required for coil voltage of magnetic contactor more than 200V class.
 11. Configure the circuit to shut down the main circuit power supply simultaneously with the turn off of forced stop (EM1) using the external sequence.
 12. Be sure to use a magnetic contactor (MC) with an operation delay time of 80ms or less. The operation delay time is the time interval between current being applied to the magnetic coil until closure of contacts.

2. SIGNALS AND WIRING

2.3 I/O signal connection example

POINT
<ul style="list-style-type: none"> For details of each signal, refer to chapter 3 of the MR-J3-□B Servo Amplifier Instruction Manual.

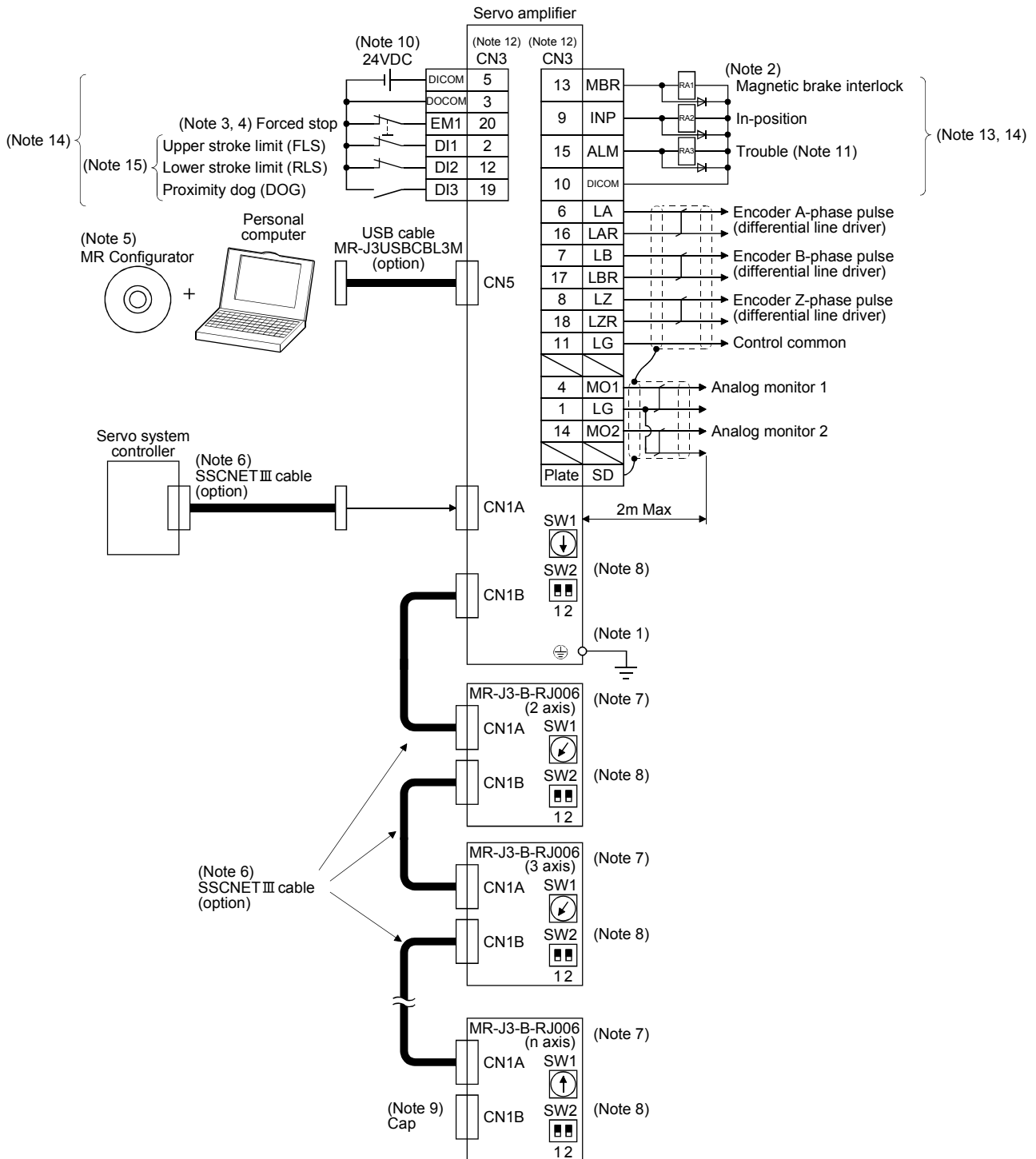

2. SIGNALS AND WIRING

Note 1 To prevent an electric shock, always connect the protective earth (PE) terminal (⊕) of the servo amplifier to the protective earth (PE) of the control box.

2. Connect the diode in the correct direction. If it is connected reversely, the servo amplifier will be faulty and will not output signals, disabling the emergency stop and other protective circuits.
3. If the controller does not have an forced stop (EM1) function, always install a forced stop switch (Normally closed).
4. When starting operation, always turn on the forced stop (EM1). (Normally closed contacts) By setting "□1□□" in the parameter No.PA04 of the servo amplifier, the forced stop (EM1) can be made invalid.
5. Use MRZJW3-SETUP 221E. (Refer to section 11.8 of the MR-J3-□B Servo Amplifier Instruction Manual)
6. Use SSCNETIII cables listed in the following table.

Cable	Cable model name	Cable length
Standard code inside panel	MR-J3BUS □ M	0.15m to 3m
Standard cable outside panel	MR-J3BUS □ M-A	5m to 20m
Long-distance cable	MR-J3BUS □ M-B	30m to 50m

7. The wiring of the second and subsequent axes is omitted.
8. Up to eight axes (n=1 to 8) may be connected. Refer to section 3.13 of the MR-J3-□B Servo Amplifier Instruction Manual for setting of axis selection.
9. Make sure to put a cap on the unused CN1A * CN1B.
10. Supply 24VDC±10% 150mA current for interfaces from the outside. 150mA is the value applicable when all I/O signals are used. The current capacity can be decreased by reducing the number of I/O points. Refer to section 3.7.2 (1) of the MR-J3-□B Servo Amplifier Instruction Manual that gives the current value necessary for the interface.
11. Trouble (ALM) turns on in normal alarm-free condition.
12. The pins with the same signal name are connected in the servo amplifier.
13. The signal can be changed by parameter No.PD07, PD08, PD09.
14. For the sink I/O interface. For the source I/O interface, refer to section 3.7.3 of the MR-J3-□B Servo Amplifier Instruction Manual.
15. Devices can be assigned for DI1 * DI2 * DI3 with controller setting. For devices that can be assigned, refer to the controller instruction manual. The assigned devices are for the Q173DCPU, Q172DCPU, Q173HCPU, Q172HCPU, Q170MCP, QD74MH□ and QD75MH□.

2. SIGNALS AND WIRING

2.4 Connector and signal arrangements

POINT
<ul style="list-style-type: none"> The pin configurations of the connectors are as viewed from the cable connector wiring section.

The servo amplifier front view shown is for MR-J3-20B-RJ006 or less. For the appearances and connector layouts of other servo amplifiers, refer to chapter 7 OUTLINE DRAWINGS.

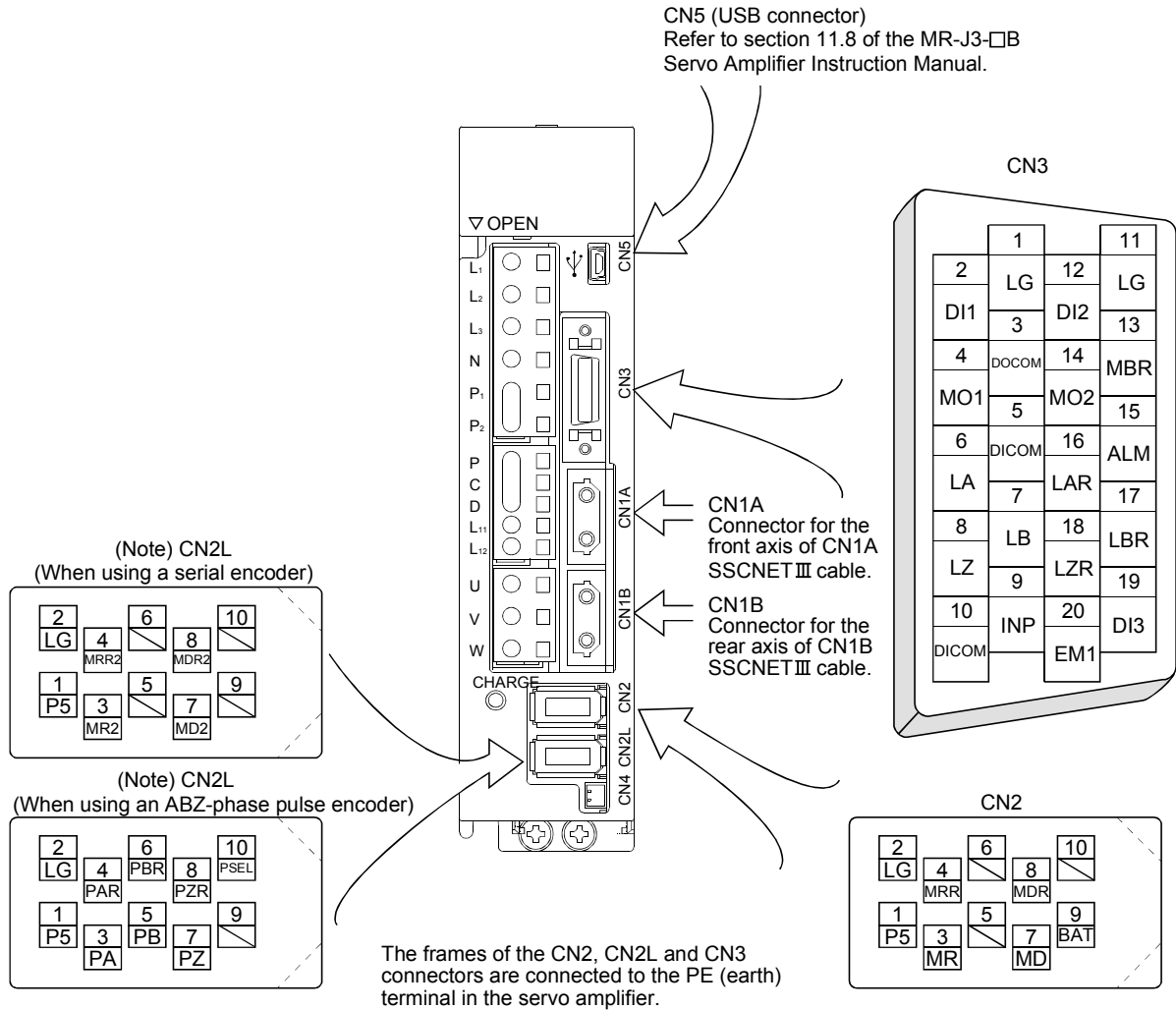

Note. The figures of connectors manufactured by 3M are shown above. When using any other connector, refer to section 11.1 of the MR-J3-□B Servo Amplifier Instruction Manual.

2. SIGNALS AND WIRING

2.5 Internal connection diagram

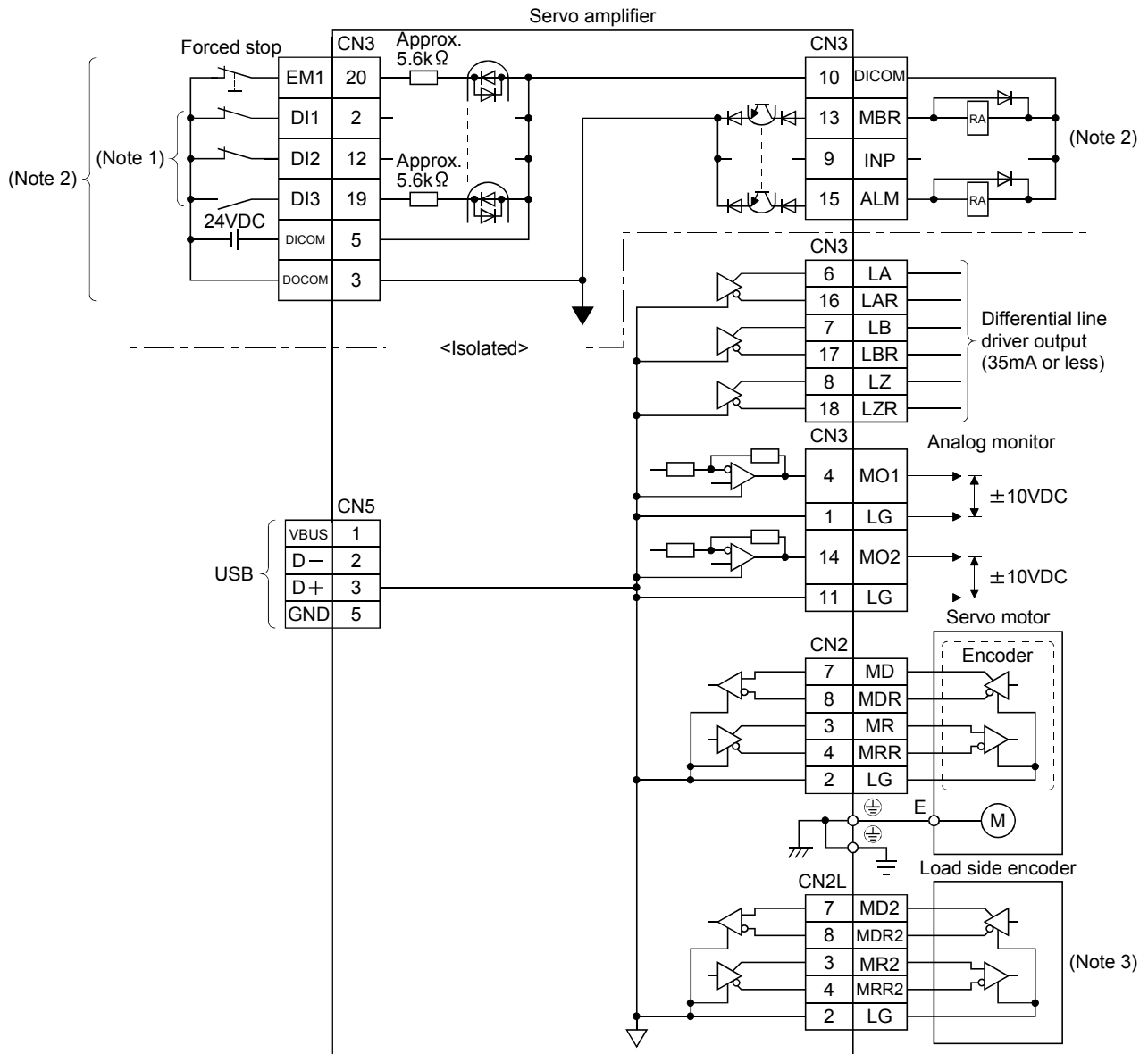

Note 1. Signal can be assigned for these pins with host controller setting.

For contents of signals, refer to the instruction manual of host controller.

2. For the sink I/O interface. For the source I/O interface, refer to section 3.7.3 of the MR-J3-□B Servo Amplifier Instruction Manual.

3. The connection diagram for the ABZ-phase output pulse train specification linear encoder is shown below.

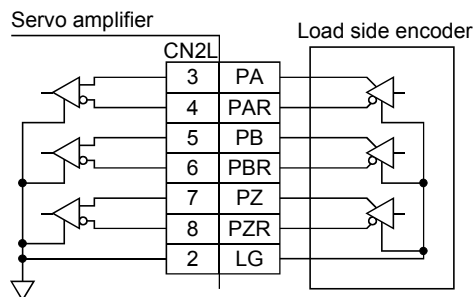

2. SIGNALS AND WIRING

2.6 Treatment of cable shield external conductor

In the case of the CN2, CN2L and CN3 connectors, securely connect the shielded external conductor of the cable to the ground plate as shown in this section and fix it to the connector shell.

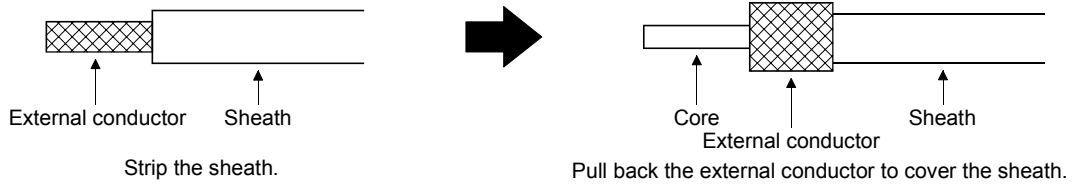

(1) For CN3 connector (3M connector)

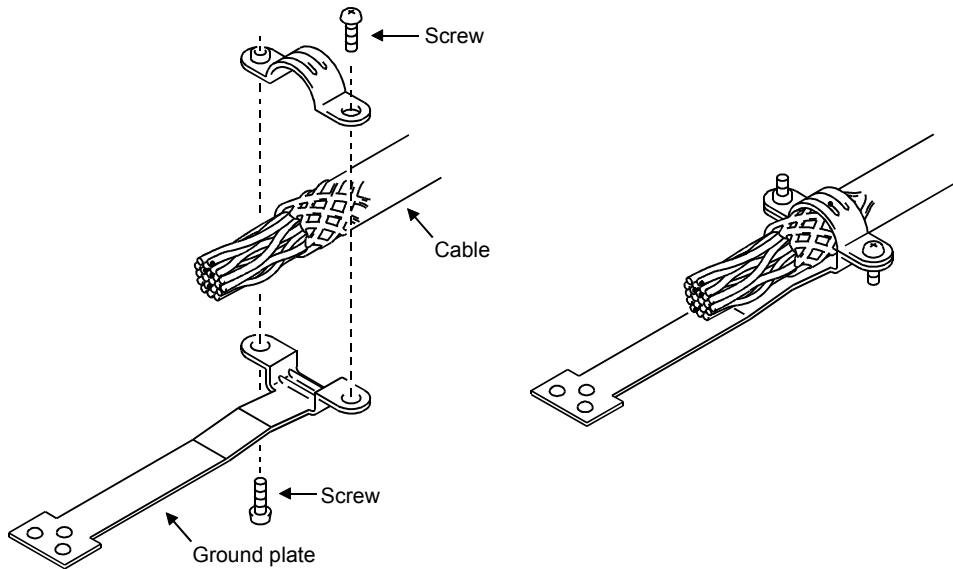

(2) For CN2 and CN2L connector (3M or Molex connector)

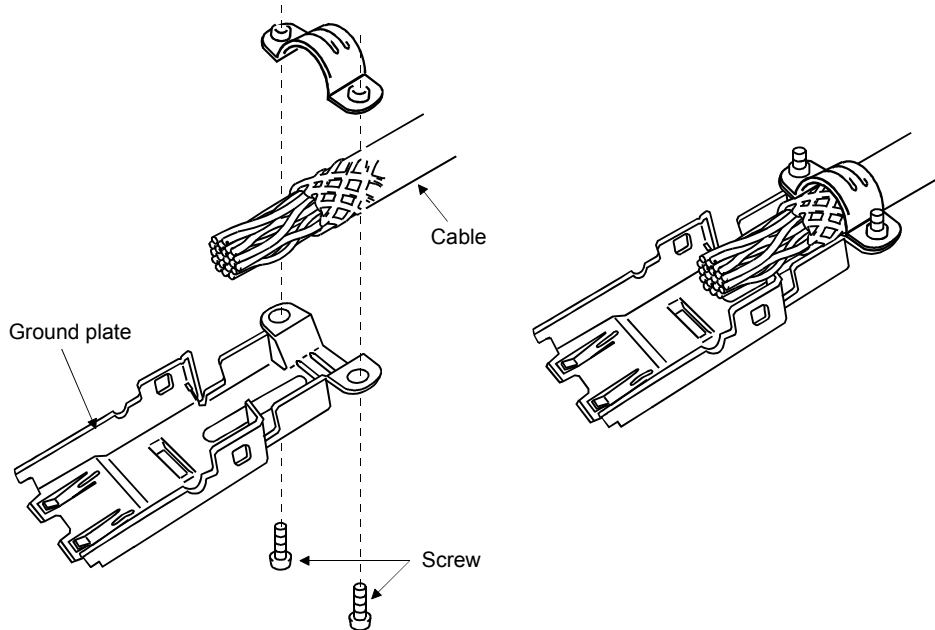

3. LOAD SIDE ENCODER

3. LOAD SIDE ENCODER

POINT
<ul style="list-style-type: none"> Always use the load side encoder cable introduced in this section. If the other products are used, a faulty may occur. For details of the load side encoder specifications, performance and assurance, contact each encoder manufacturer.

3.1 Compatible linear encoder list

Scale type	Manufacturer	Model	Resolution	Rated speed	Effective measurement length (Maximum)	Communication system	Absolute position detection system	
Mitsubishi serial interface compatibility	Mitutoyo Corporation	AT343A	0.05 μ m	2.0m/s	3000mm	2 wire type	○	
		AT543A-SC		2.5m/s	2200mm			
		ST741A	0.5 μ m	4.0m/s	6000mm			
		ST743A(Note 2)	0.1 μ m					
	Heidenhain Corporation	LC491M	0.05 μ m	2.0m/s	2040mm	4 wire type	○	
			0.01 μ m					
		LC192M	0.05 μ m	3.0m/s	4240mm			
			0.01 μ m					
	Incremental type	Sony Manufacturing System Corporation (Note 3)	SL710 +PL101R/RH +MJ830 or MJ831	0.2 μ m (Note 1)	6.4m/s	3000mm	2 wire type	×
		Renishaw Inc.	RGH26P	5.0 μ m	4.0m/s	7000mm	2 wire type	×
RGH26Q			1.0 μ m	3.2m/s	×			
RGH26R			0.5 μ m	1.6m/s	×			
Heidenhain Corporation		LIDA485 +APE391M	0.005 μ m (20/4096 μ m)	4.0m/s	30040mm	4 wire type	×	
		LIDA487 +APE391M			6040mm			
ABZ-phase differential output	Incremental type	Not specified	Remissible resolution range	Encoder dependent	Encoder dependent	Differential 3 pair type	×	

Note 1. Varies depending on the setting of the interpolator (MJ830/MJ831: Manufactured by Sony Manufacturing Systems Corporation).

2. This linear encoder is compatible with a servo amplifier with software version A1 or later.

3. Production of the SH13 has been discontinued. For details, please contact Sony Manufacturing Systems Corporation.

POINT
<ul style="list-style-type: none"> When the linear encoder is incorrectly installed, an alarm or a positioning mismatch may occur. In this case, refer to the following general checking points for the linear encoder to confirm the installation, etc. <ol style="list-style-type: none"> Check that the gap between the head and scale is proper. Check the scale head for rolling and yawing (looseness of scale head section). Check the scale surface for contamination and scratches. Check that the vibration and temperature are within the specified range. Check that the speed is within the permissible range without overshooting.

3. LOAD SIDE ENCODER

3.2 Mitsubishi serial interface compatible linear encoder

3.2.1 Linear scales manufactured by Mitutoyo Corporation (absolute type)

POINT
<ul style="list-style-type: none"> When the absolute position detection system is configured, the MR-J3BAT battery is not required.

(1) For AT343A

(a) Cable composition

Prepare a cable based on the following structure diagram.

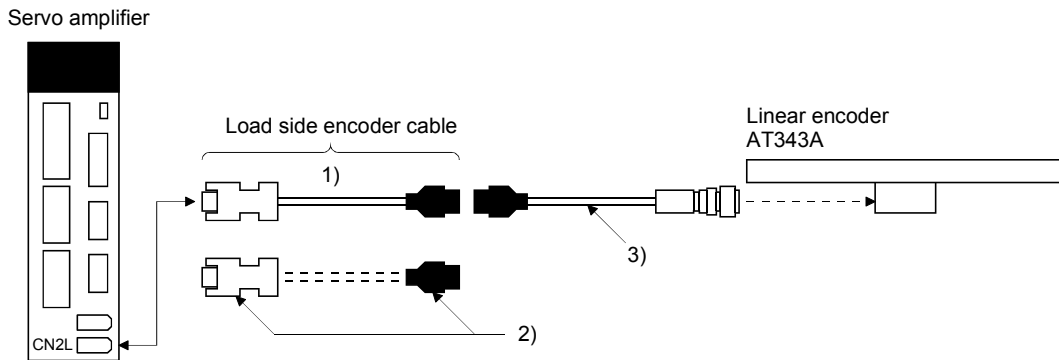

	Cable	
	Load side encoder cable	Output cable
When using an optional cable	1) MR-EKCBL□M-H (Options manufactured by Mitsubishi Electric Corporation) 2m * 5m * 10m (Refer to section 3.4.)	3) Options manufactured by Mitutoyo Corporation (Note) (This should be prepared by the customer.)
When producing a load side encoder cable	2) Connector set MR-ECNM (Option manufactured by Mitsubishi Electric Corporation) (Refer to section 3.4.)	Part No.09BAA598A: 0.2m Part No.09BAA598B: 2m Part No.09BAA598C: 3m

Note. For details, contact with Mitutoyo Corporation.

3. LOAD SIDE ENCODER

(b) Production of load side encoder cable

Produce the load side encoder cable using MR-EKCBL□M-H (10m or less) or MR-ECNM as shown below. The load side encoder cable can be produced as the length of max. 30m. The following diagram shows a connecting example of more than 5m to 10m.

Pin layout is one of the following.

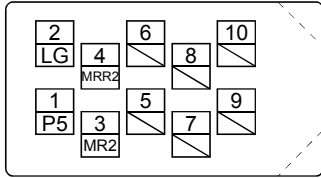

View seen from wiring side.

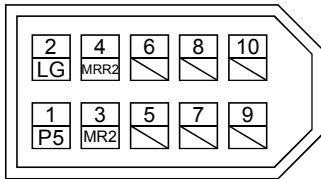

View seen from wiring side.

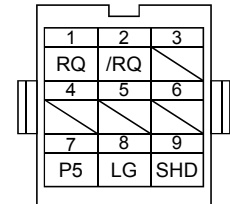
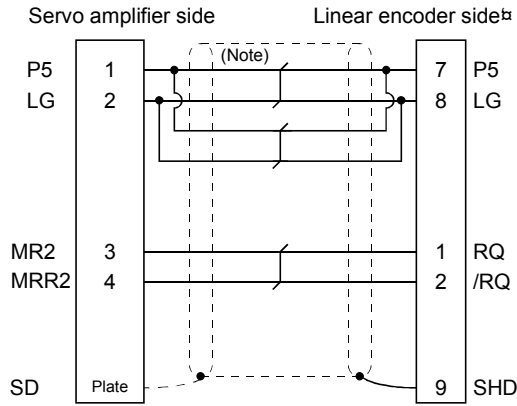

View seen from wiring side.

Note. The following table shows the cable size to be used and the number of paired connections of LG and P5.

Wiring length	Number of LG and P5 connections (when the output cable is 3m or less)	Cable size
to 5m	1-pair	AWG22
to 10m	2-pair	
to 20m	4-pair	
to 30m	6-pair	

3. LOAD SIDE ENCODER

(2) For AT543A-SC

(a) Cable composition

Prepare a cable based on the following structure diagram.

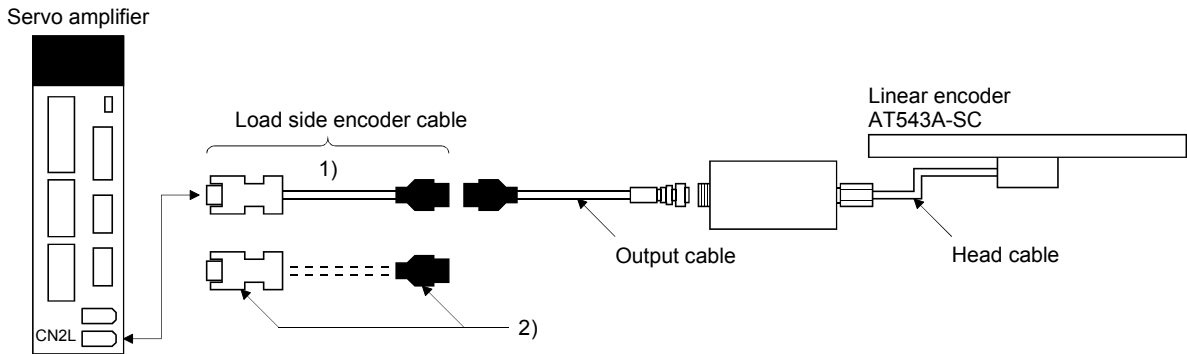

	Cable		
	Load side encoder cable	Output cable	Head cable
When using an optional cable	1) MR-EKCBL□M-H (Options manufactured by Mitsubishi Electric Corporation) 2m * 5m * 10m (Refer to section 3.4.)	Accessories for linear encoder Cable length: 3m	Accessories for linear encoder Cable length: 2m
When producing a load side encoder cable	2) Connector set MR-ECNM (Option manufactured by Mitsubishi Electric Corporation) (Refer to section 3.4.)		

(b) Production of load side encoder cable

Produce the load side encoder cable using MR-EKCBL□M-H (10m or less) or MR-ECNM as shown below. The load side encoder cable can be produced as the length of max. 30m. The following diagram shows a connecting example of more than 5m to 10m.

Pin layout is one of the following.

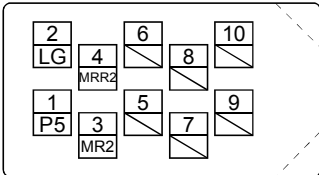

View seen from wiring side.

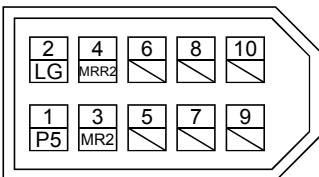

View seen from wiring side.

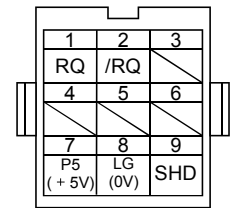
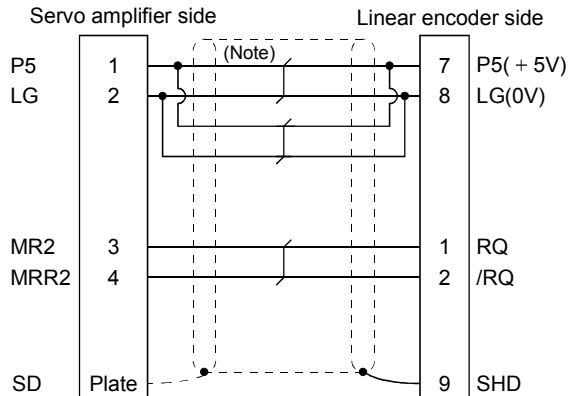

View seen from wiring side.

Note. The following table shows the cable size to be used and the number of paired connections of LG and P5.

Wiring length	Number of LG and P5 connections (when the output cable is 3m or less)	Cable size
to 5m	1-pair	AWG22
to 10m	2-pair	
to 20m	4-pair	
to 30m	6-pair	

3. LOAD SIDE ENCODER

(3) For ST741A or ST743A

(a) Cable structure

Prepare a cable based on the following structure diagram.

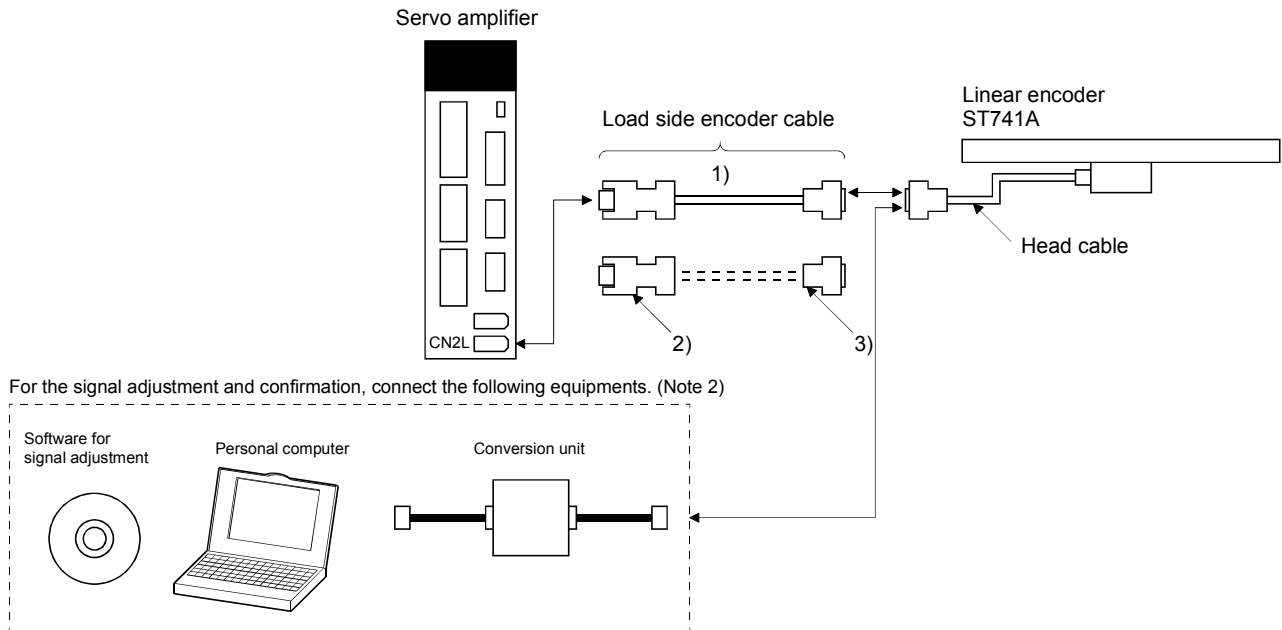

	Cable	
	Load side encoder cable	Head cable
When using an optional cable	1) Options manufactured by Mitutoyo Corporation (This should be prepared by the customer.) (Note 1) Part No.06ACF117A: 5m Part No.06ACF117B: 10m	
When producing a load side encoder cable	2) Connector set MR-J3CN2 (Option manufactured by Mitsubishi Electric Corporation) (Refer to section 3.4.)	3) Junction connector (This should be prepared by the customer.) D-SUB (female) 15 Pin shell: HDAB-15S' Plug case: HDA-CTH (manufactured by HIROSE ELECTRIC CO., LTD)

Note 1. For details, contact with Mitutoyo Corporation .

2. When mounting ST741A - ST743A, a personal computer (with RS-232C port) for the signal adjustment and confirmation, and a software and conversion unit for signal adjustment are required. For details, contact with Mitutoyo Corporation.

3. LOAD SIDE ENCODER

(b) Production of load side encoder cable

Produce the load side encoder cable using MR-J3CN2 or a junction connector as shown below. The load side encoder cable can be produced as the length of max. 30m. The following diagram shows a connecting example of more than 5m to 10m.

Connector set (option)
 MR-J3CN2
 Receptacle: 36210-0100PL
 Shell kit: 36310-3200-008
 (3M)

Pin layout is one of the following.

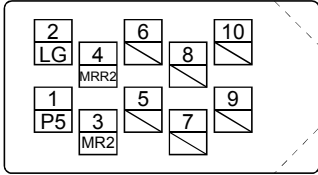

Connector set: 54599-1019
 (Molex)

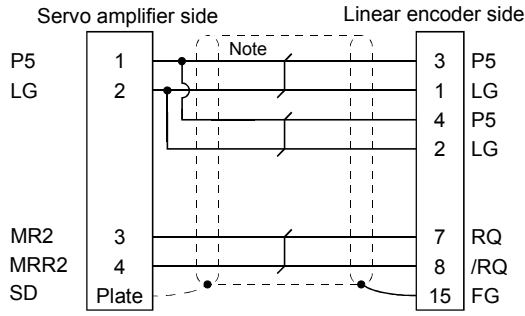
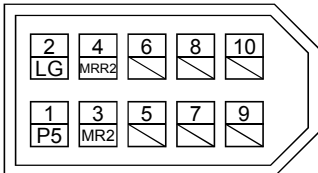

Shell : HDAB-15S
 Shield cover HDA-CTH
 (HIROSE ELECTRIC or equivalent)

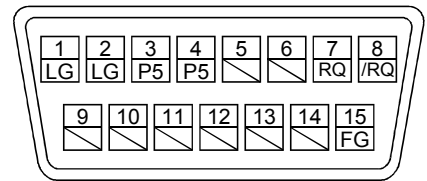

Note. The following table shows the cable size to be used and the number of paired connections of LG and P5.

Wiring length	Number of LG and P5 connections (when the head cable is 1m or less)	Cable size
to 5m	1-pair	AWG22
to 10m	2-pair	
to 20m	3-pair	
to 30m	4-pair	

3. LOAD SIDE ENCODER

3.2.2 Linear encoder manufactured by Heidenhain Corporation

POINT	<ul style="list-style-type: none"> When the absolute position detection system is configured, the MR-J3BAT battery is not required.
-------	--

(1) For LC491M or LC192M (Absolute type)

POINT	<ul style="list-style-type: none"> This linear encoder is of four-wire type. When using any of these encoder, set parameter No.PC26 to "1□□□" to select the four-wire type.
-------	--

(a) Cable structure

Prepare a cable based on the following structure diagram.

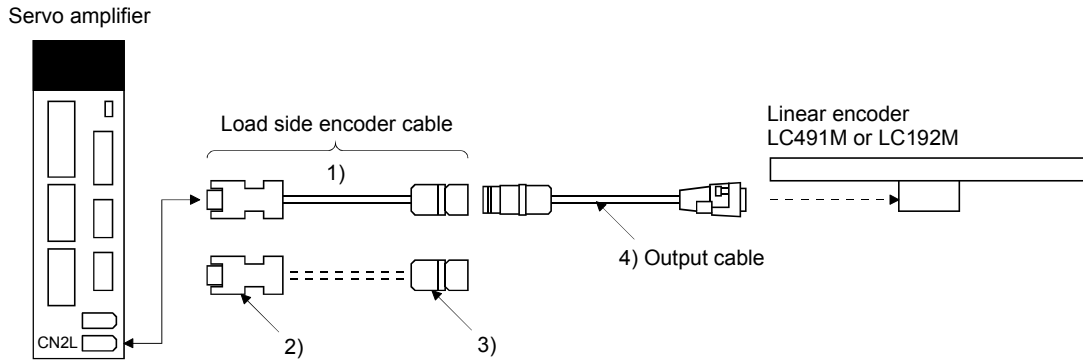

	Cable			
	Load side encoder cable		Output cable	
			LC491M	LC192M
When using an optional cable	1) Option manufactured by Heidenhain Corporation (This should be prepared by the customer.) (Note)		4) 337 439-×××××××× □m	4) 343 421-×××××××× □m
When producing a load side encoder cable	2) Connector set MR-J3CN2 (Option manufactured by Mitsubishi Electric Corporation) (Refer to section 3.4.)	3) Junction connector (This should be prepared by the customer.) 17-pin coupling (female) 291697-26 (manufactured by Heidenhain Corporation)	(manufactured by Heidenhain Corporation) (This should be prepared by the customer.)	(manufactured by Heidenhain Corporation) (This should be prepared by the customer.)

Note. For details, contact with Heidenhain Corporation.

3. LOAD SIDE ENCODER

(b) Production of load side encoder cable

Produce the load side encoder cable using MR-J3CN2 or a junction connector as shown below. The load side encoder cable can be produced as the length of max. 30m. The following diagram shows a connecting example of more than 5m to 10m.

Connector set (option)

MR-J3CN2

Receptacle: 36210-0100PL

Shell kit: 36310-3200-008

(3M)

Pin layout is one of the following.

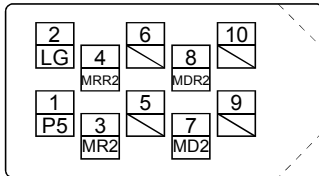

View seen from wiring side.

Connector set: 54599-1019
(Molex)

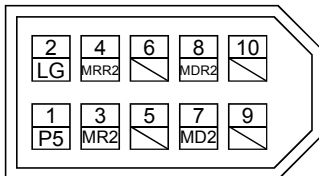

View seen from wiring side.

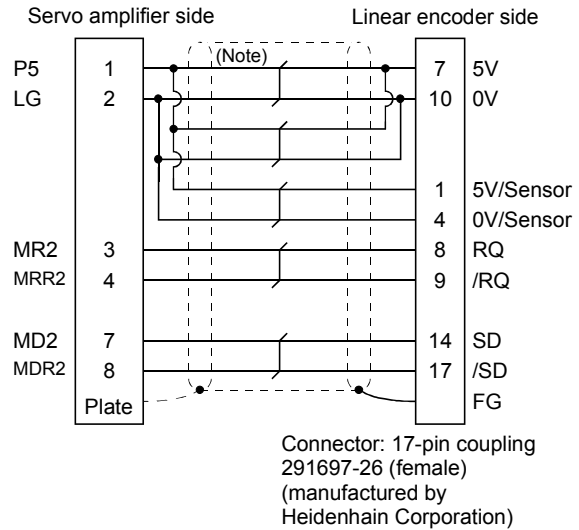

Connector: 17-pin coupling
291697-26 (female)
(manufactured by
Heidenhain Corporation)

Note. The following table shows the cable size to be used and the number of paired connections of LG and P5.

Wiring length	Number of LG and P5 connections (when the output cable is 1m or less)	Cable size
to 5m	2-pair	AWG22
to 10m	3-pair	
to 20m	5-pair	
to 30m	7-pair	

(2) For LIDA485 or LIDA487 (Incremental type)

(a) Cable structure

Prepare a cable based on the following structure diagram.

Servo amplifier

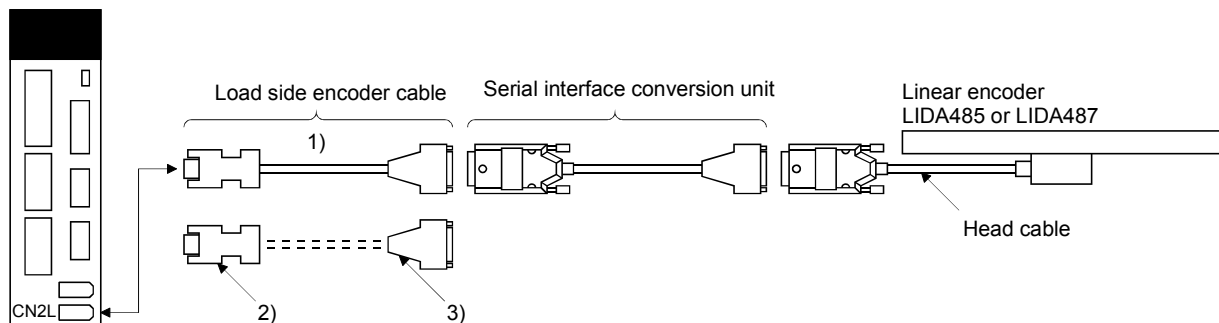

3. LOAD SIDE ENCODER

3.2.3 Linear encoder manufactured by Sony Manufacturing Systems Corporation (Incremental type)

(1) Cable structure

POINT
<ul style="list-style-type: none"> When turning on the power, turn on the interpolator and then turn on the servo amplifier. When turning off the power, turn off the servo amplifier and then turn off the interpolator.

Prepare a cable based on the following structure diagram.

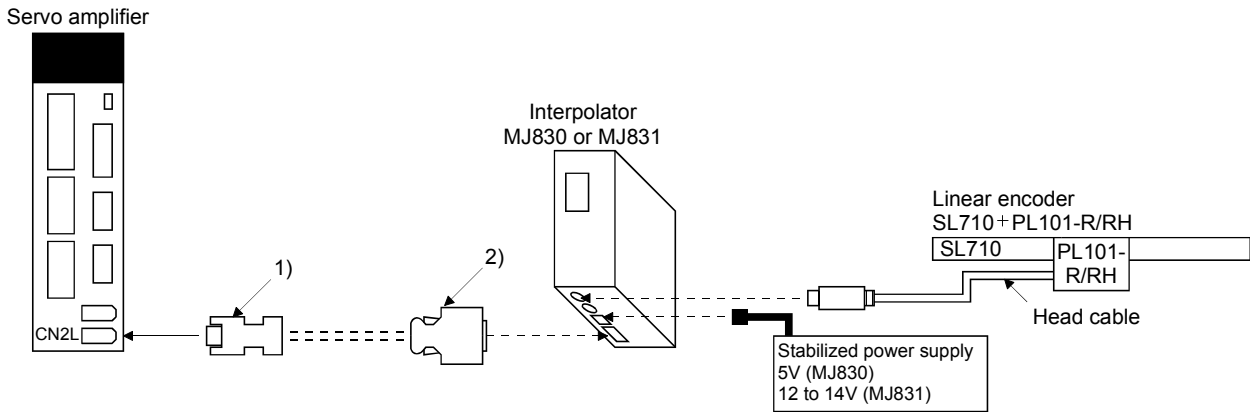

Linear encoder	Cable		Interpolator (This should be prepared by the customer.)
	Load side encoder cable (Note)	Head cable	
SL710+PL101-R/RH	1) Connector set MR-J3CN2 (Option manufactured by Mitsubishi Electric Corporation) (Refer to section 3.4.)	2) Connector for Interpolator (This should be prepared by the customer.) Connector: 10114-3000PE Shell kit: 10314-52F0-008 (3M or equivalent)	Accessories for linear encoder Cable Length PL101-R: 0.3m PL101-RH: 3m

Note. Produce an encoder cable. An optional cable is not provided.

3. LOAD SIDE ENCODER

(2) Production of load side encoder cable

Produce the load side encoder cable using MR-J3CN2 or a connector for interpolator as shown below. The load side encoder cable can be produced as the length of max. 30m. Supply linear encoder power from external.

Connector set (option)
 MR-J3CN2
 Receptacle: 36210-0100PL
 Shell kit: 36310-3200-008
 (3M)

Pin layout is one of the following.

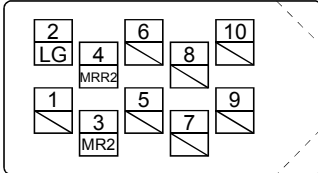

View seen from wiring side.

Connector set: 54599-1019
 (Molex)

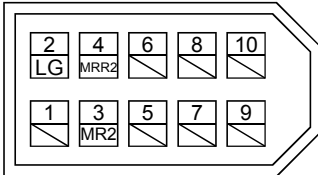

View seen from wiring side.

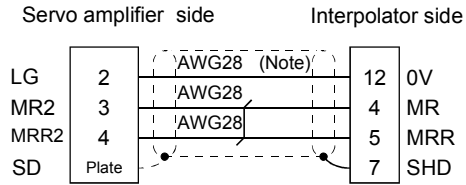

Connector: 10114-3000PE
 : 10314-52F0-008
 (3M or equivalent)

Note. Connect the LG of the servo amplifier to the 0V of the load side encoder.

In addition, it is not necessary to increase the number of connections according to the wiring length.

3. LOAD SIDE ENCODER

3.2.4 Linear encoder manufactured by Renishaw Inc. (Incremental type)

(1) Cable structure

Prepare a cable based on the following structure diagram.

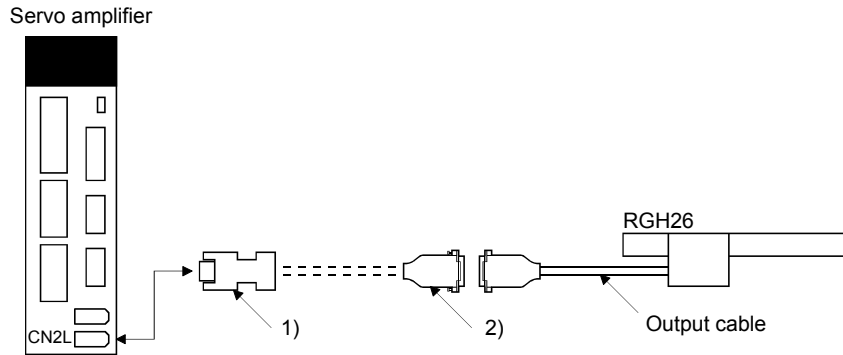

Cable		
Load side encoder cable		Output cable
1) Connector set (Option manufactured by Mitsubishi Electric Corporation) (Refer to section 3.4.)	2) Junction connector (This should be prepared by the customer.) D-SUB15 pin (female)	Accessories for linear encoder Cable Length 0.5m

Note. Produce an encoder cable. An optional cable is not provided

3. LOAD SIDE ENCODER

(2) Production of load side encoder cable

Produce the load side encoder cable using MR-J3CN2 or a junction connector as shown below. The load side encoder cable can be produced as the length of max. 30m.

Connector set (option)
MR-J3CN2
Receptacle: 36210-0100PL
Shell kit: 36310-3200-008
(3M)

Pin layout is one of the following.

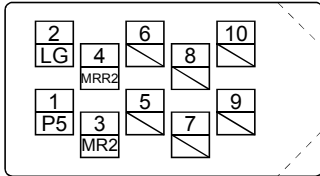

View seen from wiring side.

Connector set: 54599-1019
(Molex)

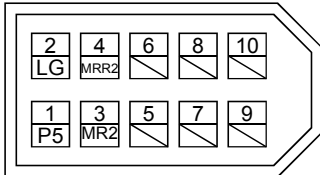

View seen from wiring side.

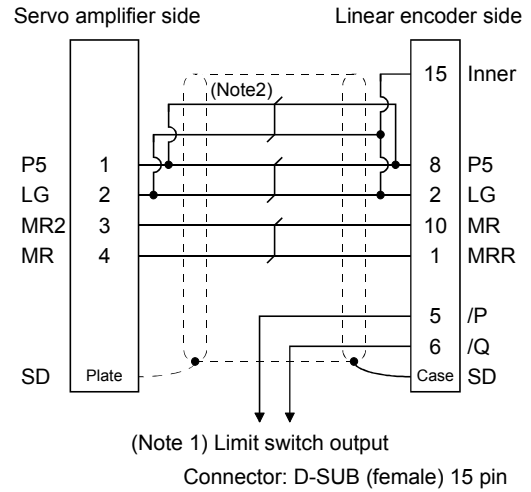

Note 1. A limit switch output signal can be connected. For details, contact with Renishaw Inc.

2. The following table shows the cable size to be used and the number of paired connections of LG and P5.

Wiring length	Number of LG and P5 connections (when the output cable is 0.5m or less)	Cable size
to 5m	1-pair	AWG22
to 10m	2-pair	
to 20m	4-pair	
to 30m	6-pair	

3. LOAD SIDE ENCODER

3.3 ABZ-phase differential output load side encoder

This section describes the connection of the ABZ-phase differential output load side encoder. Prepare the MR-J3CN2 connector set for the load side encoder cable and produce it according to the wiring diagram in (3) in this section.

(1) ABZ-phase differential output load side encoder specifications

Each signal of the A, B and Z-phase of the load side encoder is provided in the differential line driver output. It cannot be provided in the collector output.

The phase differences of the A- and B-phase pulses and the pulse width of the Z-phase pulse need to be 200ns or more.

The load side encoder without the Z-phase cannot make a home position return.

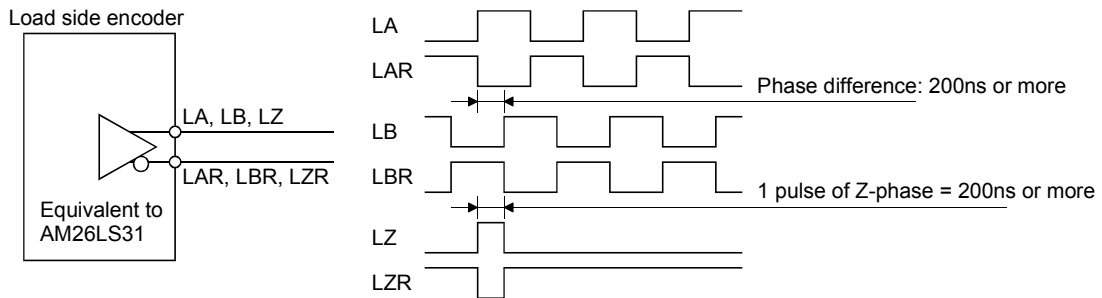

(2) Connection of servo amplifier and ABZ-phase differential output load side encoder

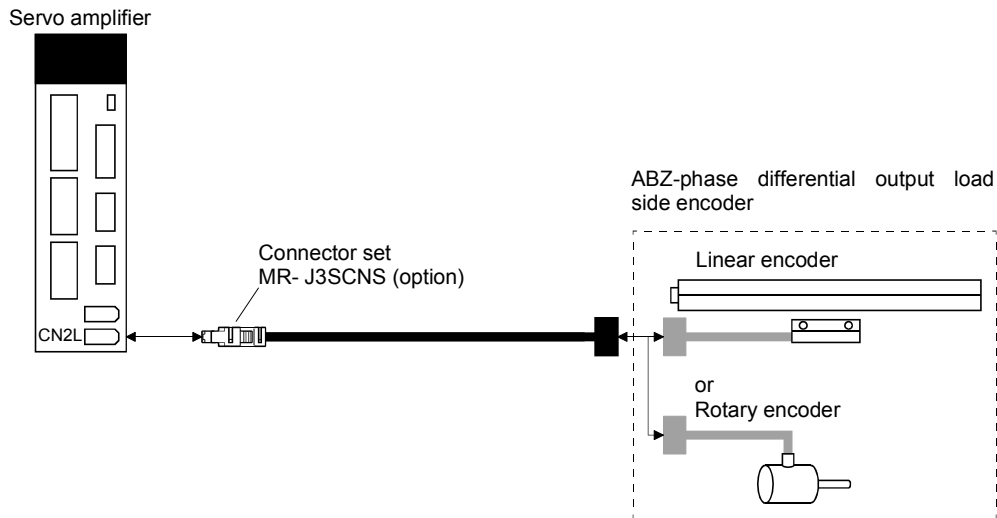

3. LOAD SIDE ENCODER

(3) Internal wiring diagram

For production of the load side encoder cable, use a cable durable against the long period of flexing action. Even though the cable length is max. 30m for the RS-422 communication, the length may be shortened due to the power supply voltage drop or the specifications of linear encoder. A connection example is shown below. For details, contact with the encoder manufacturer.

1) When the consumption current of the load side encoder is 350mA or less

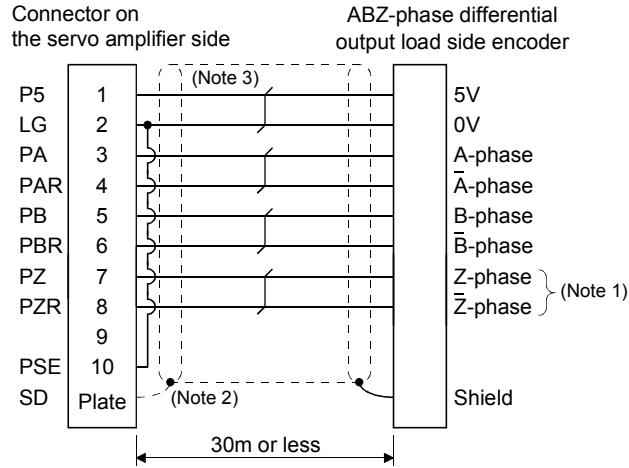

Note 1. For the load side encoder without Z-phase, set parameter No.PC27 to "□1□□".

2. Securely connect a shield cable to the plate (ground plate) in the connector.

3. The following table shows the cable size to be used and the number of paired connections of LG and P5 when the consumption current of the load side encoder is 350mA. When the consumption current of the load side encoder is 350mA or less, the paired connections can be decreased.

Wiring length	Number of LG and P5 connections	Cable size
to 5m	2-pair	AWG22
to 10m	3-pair	
to 20m	6-pair	
to 30m	8-pair	

3. LOAD SIDE ENCODER

2) When the consumption current of the load side encoder is more than 350mA

POINT
<ul style="list-style-type: none"> When turning on the power, turn on the load side encoder and then turn on the servo amplifier. When turning off the power, turn off the servo amplifier and then turn off the load side encoder.

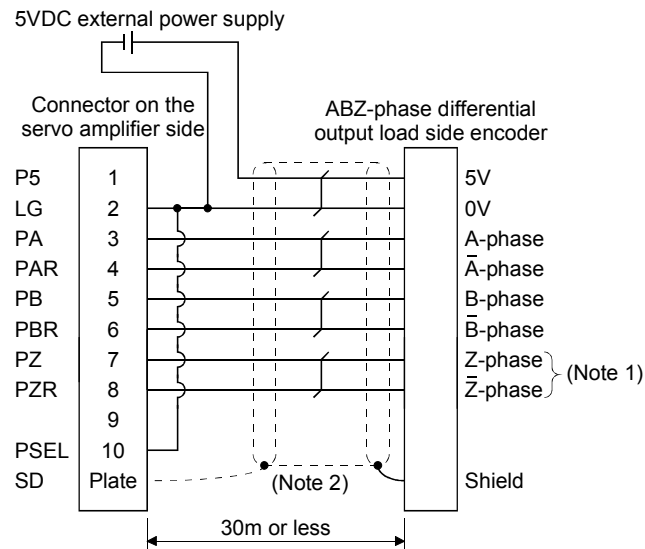

Note 1. For the load side encoder without Z-phase, set parameter No.PC27 to "□1□□".

2. Securely connect a shield cable to the plate (ground plate) in the connector.

3. LOAD SIDE ENCODER

3.4 Mitsubishi optional cable • connector sets

POINT	<ul style="list-style-type: none"> The IP rating indicated is the cable's or connector's protection against ingress of dust and water when the cable or connector is connected to a servo amplifier or servo motor. If the IP rating of the cable, connector, servo amplifier or servo motor vary, the overall IP rating depends on the lowest IP rating of all components.
-------	--

3.4.1 MR-EKCBL□M-H

(1) Model explanations

Model : MR - E K C B L □ M - H

└── Long flex life

Symbol	Cable length [m]
2	2
5	5
10	10

(2) Cable structure

The table shows this optional cable structure.

IP rating	Flex life	Length [m]	Core size [mm ²]	Number of cores	Characteristics of one core			(Note 2) Finishing OD [mm]	Wire model
					Structure [Wires/mm]	Conductor resistance [Ω /mm]	Insulation coating OD d [mm] (Note 1)		
IP20	Long flex life	2 • 5 • 10	0.2mm ²	12 (6 pairs)	40/0.08	105 or less	0.88	7.2	(Note 3) A14B2339 6P

Note 1. d is as shown below.

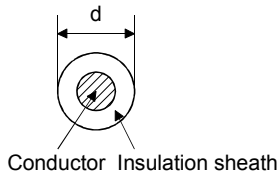

2. Standard OD. Max. OD is about 10% greater.
3. Purchased from Toa Electric Industry.

3. LOAD SIDE ENCODER

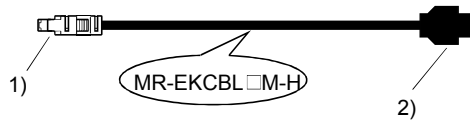

Cable model	1) CN2 connector	2) Junction connector
MR-EKCBL □ M-H	<p>Connector set: 54599-1019 (Molex or equivalent)</p> <p>(Note) Signal layout</p> <p>View seen from wiring side.</p> <p>Note. Keep open the pins shown with . Especially, pin 10 is provided for manufacturer adjustment. If it is connected with any other pin, the servo amplifier cannot operate normally.</p>	<p>Housing: 1-172161-9 Connector pin: 170359-1 (Tyco Electronics or equivalent) Cable clamp: MTI-0002 (Toa Electric Industries)</p> <p>Signal layout</p> <p>View seen from wiring side.</p>

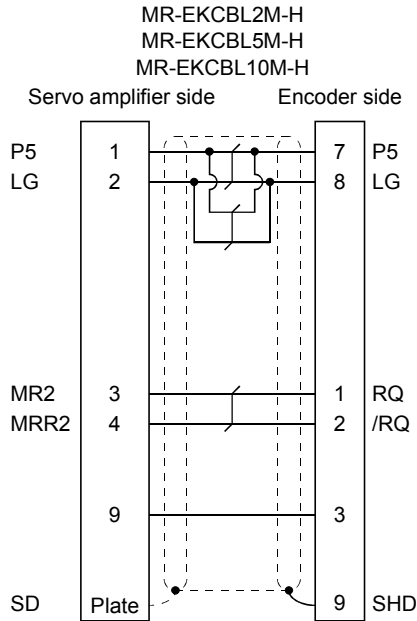

(3) Internal wiring diagram



3. LOAD SIDE ENCODER

3.4.2 MR-ECNM

The following shows the connector combination for this connector set.

Parts	Description
Connector set	<p data-bbox="624 389 730 416">MR-ECNM</p> <div style="display: flex; justify-content: space-around; align-items: center;">   </div> <p data-bbox="624 506 887 595">For CN2 connector Connector set: 54599-1019 (Molex)</p> <p data-bbox="1035 506 1342 685">Junction connector Housing: 1-172161-9 Connector pin: 170359-1 (Tyco Electronics or equivalent) Cable clamp: MTI-0002 (Toa Electric Industries)</p>

3.4.3 MR-J3CN2

The following shows the details of this connector set.

Connector set (option)
MR-J3CN2
Receptacle: 36210-0100PL
Shell kit: 36310-3200-008
(3M)

Connector set: 54599-1019
(Molex)

Pin layout is one of the following.

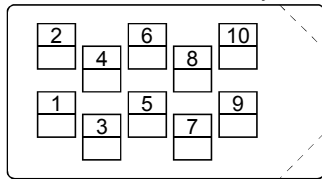

View seen from wiring side.

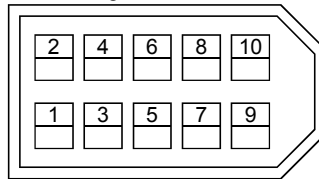

View seen from wiring side.

4. OPERATION AND FUNCTIONS

4. OPERATION AND FUNCTIONS

4.1 Startup

4.1.1 Startup procedure

Start up the fully closed loop system in the following procedure.

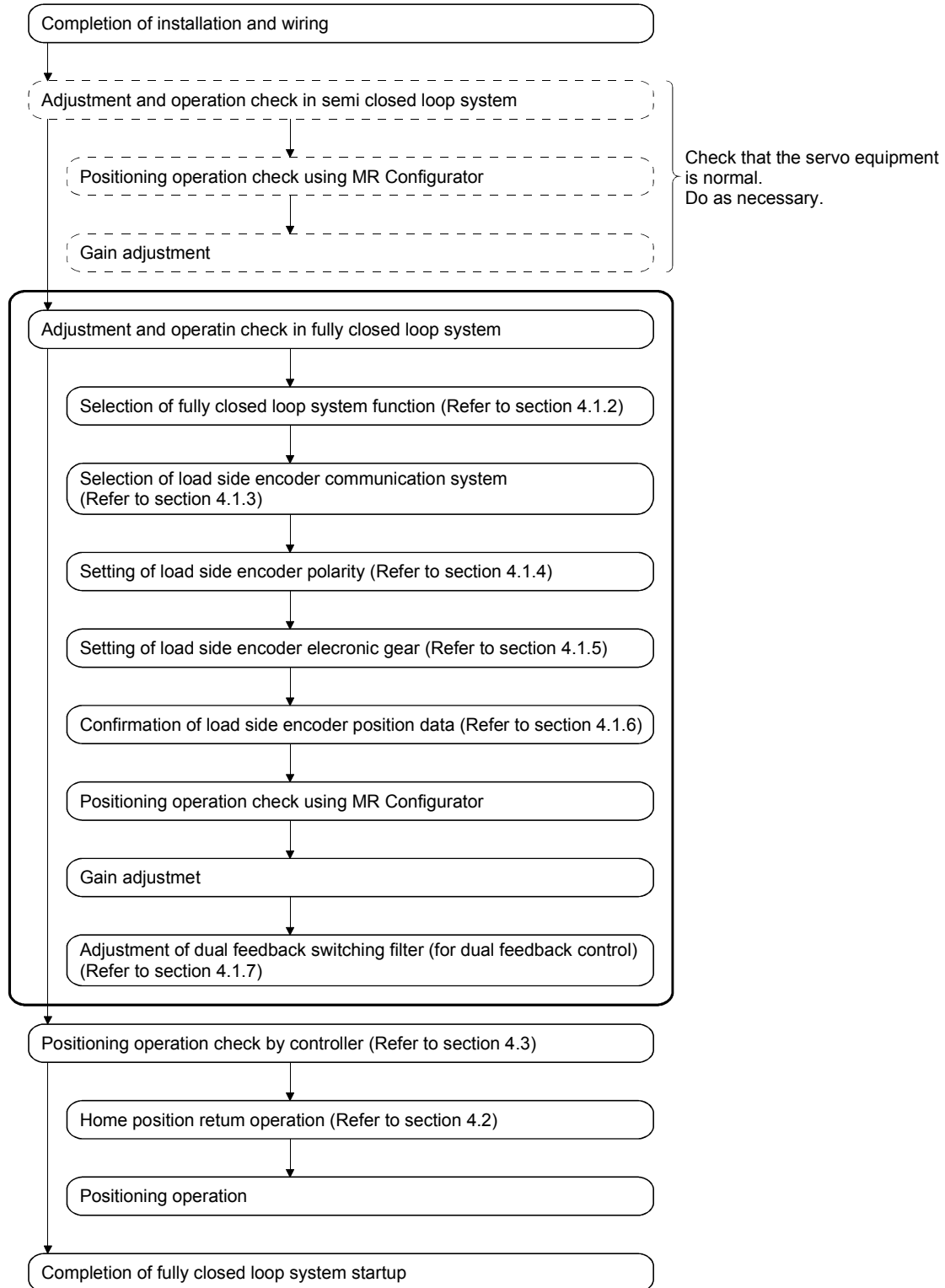

4. OPERATION AND FUNCTIONS

4.1.2 Selection of fully closed loop system

By setting parameter No.PA01, PE01 and the control command of controller, the following operations can be made.

Parameter No. PA01	Parameter No. PE01	Semi closed loop control/fully closed loop control change command	Command unit	Control method	Absolute position detection system
□□□	/	/	Motor encoder unit	Semi closed loop control	○
□□1□			Load side encoder unit	Dual feedback control (fully closed loop control)	○ (Note)
fully closed loop system	□□□0	OFF		Semi closed loop control	×
	□□□1	ON		Dual feedback control (fully closed loop control)	×

Note. Applicable when the load side encoder is set as the absolute position encoder.

(1) Control mode selection

Select a control mode.

Parameter No.PA01

0 0 □ 0

Control mode selection
 0: Semi closed loop system
 1: Fully closed loop system

Set value	Control mode	Control unit
□□0□	Semi closed loop system	Motor side resolution unit
□□1□	Fully closed loop system	Load side resolution unit

(2) Semi closed loop control/fully closed loop control selection

Select the semi closed loop control/fully closed loop control.

Parameter No.PE01

0 0 0 □

Fully closed loop control selection
 0: Always fully closed loop control
 1: Selection using the control command of controller

Selection using the control command of controller	Control method
OFF	Semi closed loop control
ON	Fully closed loop control

When parameter No.PA01 control configuration is set to "□□1□" (fully closed loop system), this setting is enabled.

4. OPERATION AND FUNCTIONS

4.1.3 Selection of load side encoder communication system

The communication system changes depending on the load side encoder type.

Refer to 3.1 for the communication system of the load side encoder.

Select the cable to be connected to CN2L connector in parameter No.PC26.

Parameter No.PC26

	1	0	0
--	---	---	---

Load side encoder cable communication system selection

0: 2-wire type

1: 4-wire type

If the setting is incorrect, the load side encoder error1 (70) or load side encoder error2 (71) occurs.

4.1.4 Setting of load side encoder polarity



CAUTION

- Do not set a wrong value in the encoder direction of parameter No.PC27 (encoder pulse count polarity selection). An abnormal operation and a machine collision may occur if a wrong value is set, which cause a fault and parts damaged.

POINT

- Parameter No.PC27 (encoder pulse count polarity selection) is not related to parameter No.PA14 (rotation direction selection). Make sure to set the parameter according to the relationships between servo motor and linear encoder • rotary encoder.
- Do not set a wrong value in the encoder direction of parameter No.PC27 (encoder pulse count polarity selection). During the positioning operation, a fully closed loop control error (42) may occur.

(1) Parameter setting method

Set the load side encoder polarity to be connected to CN2L connector in order to match the CCW direction of servo motor and the increasing direction of load side encoder feedback.

Parameter No.PC27

0	0	0	
---	---	---	--

Load side encoder pulse count polarity selection

0: Load side encoder pulse increasing direction in the servo motor CCW

1: Load side encoder pulse decreasing direction in the servo motor CCW

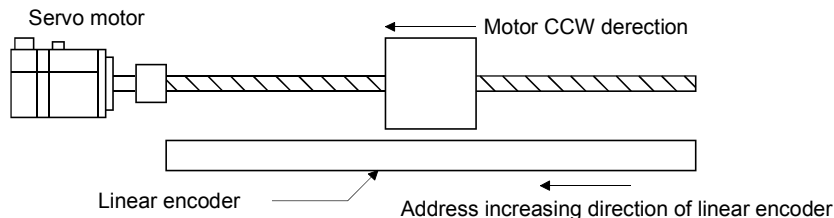

(2) How to confirm the load side encoder feedback direction

For the may to confirm the load side encoder feedback direction, refer to section 4.1.6.

4. OPERATION AND FUNCTIONS

4.1.5 Setting of feedback pulse electronic gear

POINT
<ul style="list-style-type: none"> If setting a wrong value in the feedback pulse electronic gear (parameter No. PE04, PE05, PE34, PE35), a parameter error (37) and an abnormal operation may occur. Also, a fully closed loop control error (42) may occur during the positioning operation.

The numerator (parameter No. PE04, PE34) and denominator (parameter No. PE05, PE35) of the electronic gear are set to the motor side encoder pulse. Set the electronic gear so that the number of motor encoder pulses per motor revolution is converted to the number of load side encoder pulses. The relational expression is shown below.

$$\frac{\text{Parameter No. PE04} \times \text{Parameter No. PE34}}{\text{Parameter No. PE05} \times \text{Parameter No. PE35}} = \frac{\text{Number of load side encoder pulses per servo motor revolution}}{\text{Number of motor encoder pulses per servo motor revolution}}$$

Select the load side encoder so that the number of load side encoder pulses per servo motor revolution is within the following range.

$$4096 (2^{12}) \leq \text{Number of load side encoder pulses per servo motor revolution} \leq 67108864 (2^{26})$$

(1) When the servo motor is directly coupled with a ball screw and the linear encoder resolution is 0.05μm

Condition

Servo motor resolution: 262144 pulse/rev

Servo motor reduction ratio: 1/11

Ball screw lead: 20mm

Linear encoder resolution: 0.05μm

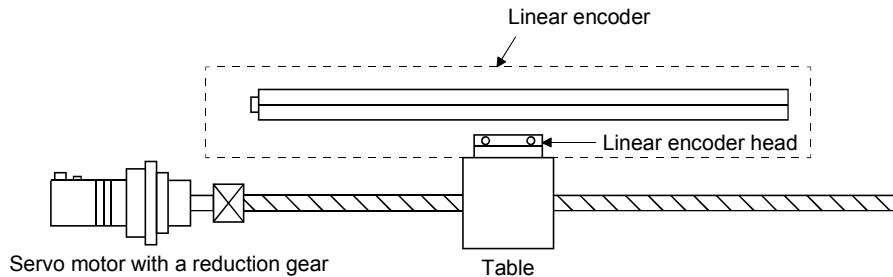

Number of linear encoder pulses per ball screw revolution is calculated.

Number of linear encoder pulses per ball screw revolution

$$= \text{Ball screw lead} / \text{Linear encoder resolution}$$

$$= 20\text{mm} / 0.05\mu\text{m} = 400000 \text{ pulse}$$

$$\frac{1) \text{ Parameter No. PE04} \times 2) \text{ Parameter No. PE34}}{3) \text{ Parameter No. PE05} \times 4) \text{ Parameter No. PE35}} = \frac{400000}{262144} \times \frac{1}{11} = \frac{1) 3125}{3) 22528} \times \frac{2) 1}{4) 1}$$

4. OPERATION AND FUNCTIONS

(2) Setting example when using the rotary encoder for the load side encoder of roll feeder

Condition

Servo motor resolution: 262144pulse/rev

Pulley diameter on the servo motor side: 30mm

Pulley diameter on the servo motor side: 20mm

Rotary encoder resolution: 5000pulse/rev

(20000 pulse/rev after multiplication by 4)

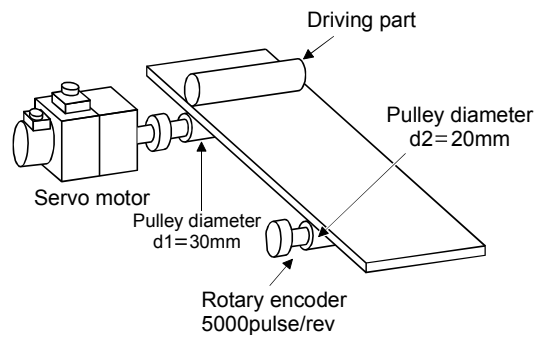

When the pulley diameters or reduction ratios differ, consider that in calculation.

For the rotary encoder, make calculation using the number of pulses multiplied by 4.

$$\frac{1) \text{ Parameter No. PE04} \times 2) \text{ Parameter No. PE34}}{3) \text{ Parameter No. PE05} \times 4) \text{ Parameter No. PE35}} = \frac{20000 \times 30}{262144 \times 20} = \frac{1) 1875}{3) 16384} \times \frac{2) 1}{4) 1}$$

4. OPERATION AND FUNCTIONS

4.1.6 Confirmation of load side encoder position data

Check the load side encoder mounting and parameter settings for any problems.

POINT
<ul style="list-style-type: none"> Depending on the check items, the MR Configurator may be used. <p>Refer to section 4.6 for the data displayed on the MR Configurator.</p>

When checking the following items, the fully closed loop control mode must be set. For the setting of control mode, refer to section 4.1.2.

No.	Check item	Checking method/Description
1	Read of load side encoder position data	With the load side encoder in a normal state (mounting, connection, etc.), the load side cumulative feedback pulses value is counted normally when the load side encoder is moved.
2	Read of load side encoder scale home position (reference mark, Z-phase)	With the linear encoder home position (reference mark, Z-phase) of the load side encoder in a normal condition (mounting, connection, etc.), the value of load side encoder information 1 is cleared to 0 when the linear encoder home position (reference mark, Z-phase) is passed through by moving the load side encoder.
3	Confirmation of load side encoder feedback direction (Setting of load side encoder polarity)	Confirm that the directions of the cumulative feedback pulses of motor encoder (after gear) and the load side cumulative feedback pulses are matched by moving the device (load side encoder) manually in the servo off status. If mismatched, reverse the polarity.
4	Setting of load side encoder electronic gear	<p>When the servo motor and load side encoder operate synchronously, the motor side cumulative feedback pulses (after gear) and load side cumulative feedback pulses are matched and increased.</p> <p>If mismatched, review the setting of fully closed loop control feedback electronic gear (parameter No. PE04, PE05, PE34, PE35) with the following method.</p> <ol style="list-style-type: none"> 1) Check the motor side cumulative feedback pulses (before gear). 2) Check the load side cumulative feedback pulses. 3) Check that the ratio of above 1) and 2) has been that of the feedback electronic gear.

4. OPERATION AND FUNCTIONS

4.1.7 Setting of fully closed loop dual feedback filter

With the initial value (setting = 10) set in parameter No.PE08, make gain adjustment by auto tuning, etc. as in semi closed loop control.

While observing the servo operation waveform with the graph function, etc. of the MR Configurator, adjust the dual feedback filter.

The dual feedback filter operates as described below depending on the setting.

Parameter No.PE08 setting value	Control mode	Vibration	Settling time
0	Semi closed loop		
1 to 4499	Dual feedback	Hard-to-occur to Easy-to-occur	Longer to Shorter
4500	Fully closed loop		

Increasing the dual feedback filter setting shortens the settling time, but increases motor vibration since the motor is more likely to be influenced by the load side encoder vibration.

The maximum setting of the dual feedback filter should be less than half of the PG2 setting.

Reduction of settling time: Increase the dual feedback filter setting.

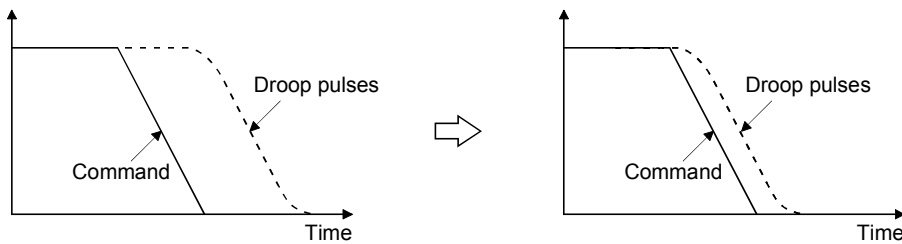

Suppression of vibration: Decrease the dual feedback filter setting.

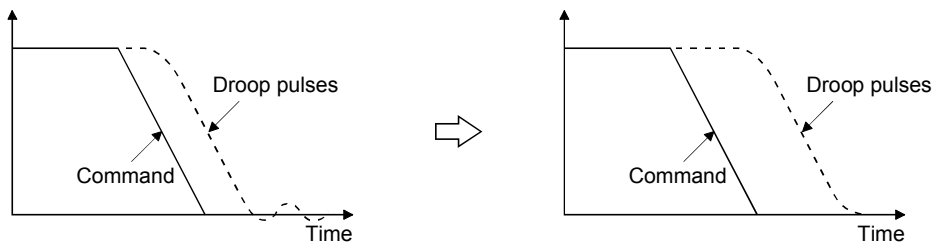

4. OPERATION AND FUNCTIONS

4.2 Home position return operation

4.2.1 General precautions

Home position return operation is all performed according to the load side encoder feedback data, independently of the load side encoder type. It is irrelevant to the Z-phase position of the motor encoder.

In the case of a home position return using a dog signal, the scale home position (reference mark) must be passed through when an incremental type linear encoder is used, or the Z-phase be passed through when a rotary encoder is used, during a period from a home position return start until the dog signal turns off.

4.2.2 Load side encoder types and home position return methods

(1) About proximity dog type home position return using absolute type linear encoder

When an absolute type linear encoder is used, the home position reference position is the position per servo motor revolution to the linear encoder home position (absolute position data = 0).

In the case of a proximity dog type home position return, the nearest position after proximity dog OFF is the home position.

The linear encoder home position may be set in any position.

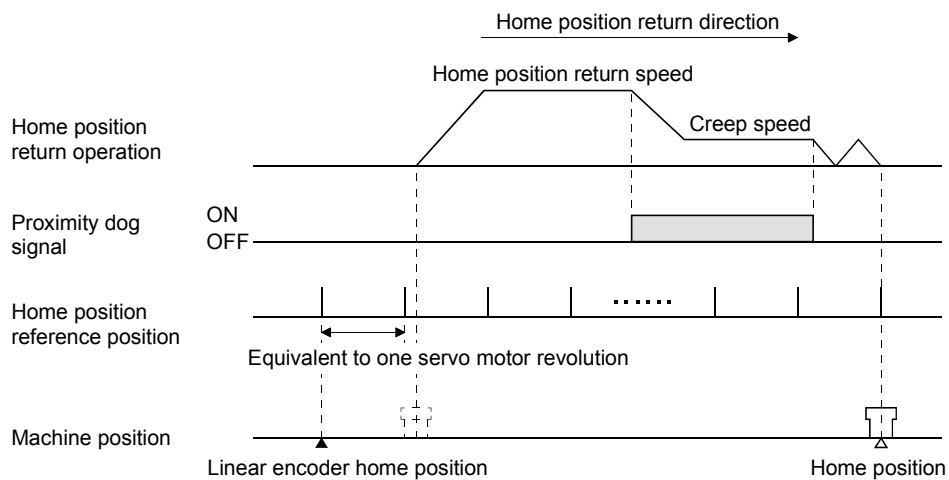

4. OPERATION AND FUNCTIONS

(2) About proximity dog type home position return using incremental linear encoder

(a) When the linear encoder home position (reference mark) exists in the home position return direction

When an incremental linear encoder is used, the home position is the position per servo motor revolution to the Linear encoder home position (reference mark) passed through first after a home position return start.

In the case of a proximity dog type home position return, the nearest position after proximity dog OFF is the home position.

Set one linear encoder home position in the full stroke, and set it in the position that can always be passed through after a home position return start.

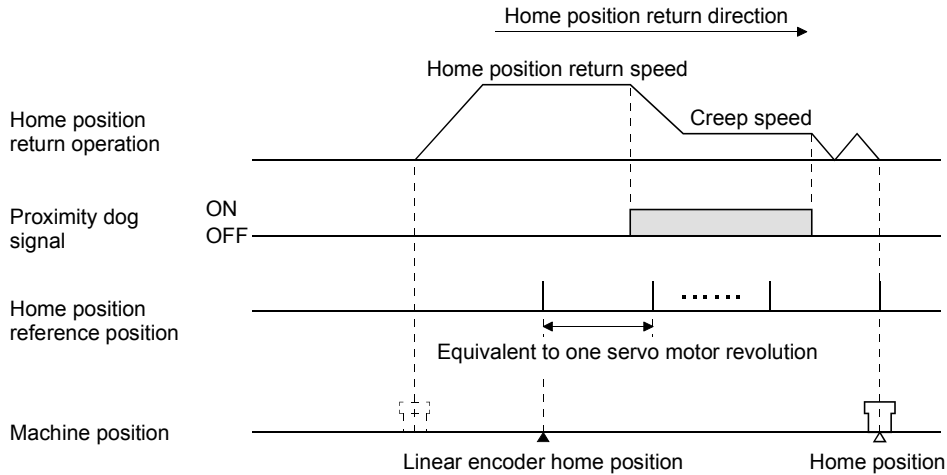

(b) When the linear encoder home position does not exist in the home position return direction

If a home position return is started at the position where the linear encoder home position (reference mark) does not exist in the home position return direction, a home position return error occurs in the controller, the error definition changes depending on the controller type. When starting a home position return at the position where the linear encoder home position (reference mark) does not exist in the home position return direction, move the axis up to the stroke end on the side opposite to the home position return direction by jog operation, etc. of the controller once, then make a home position return.

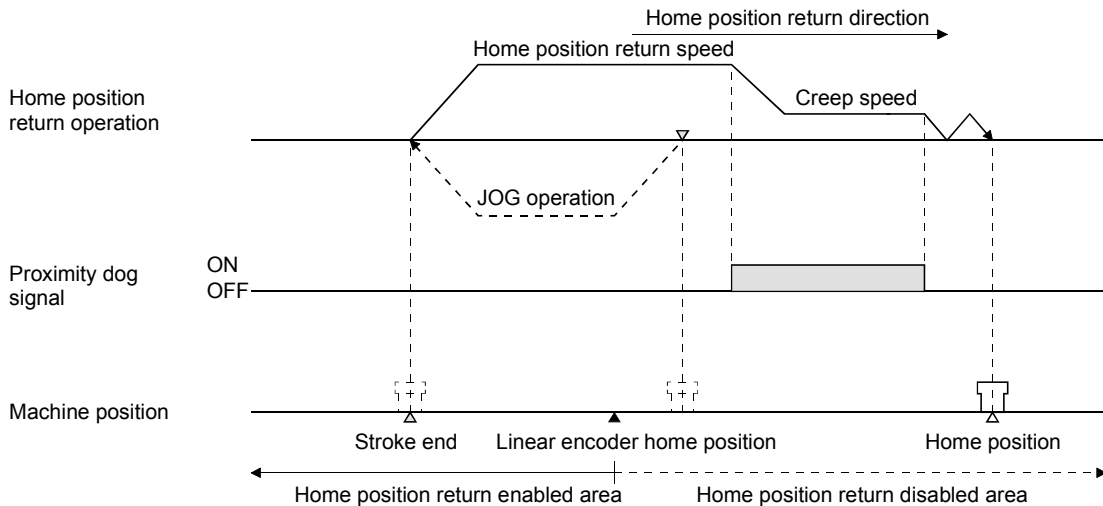

POINT

- To execute a home position return securely, start a home position return after moving the axis to the opposite stroke end by jog operation, etc. of the controller.
- To execute a home position return securely, start a home position return after moving the axis to the opposite stroke end if the incremental linear encoder does not have a linear encoder home position (reference mark). Always provide a linear encoder home position (reference mark). (One place in the fully stroke)

4. OPERATION AND FUNCTIONS

(3) About dog type home position return when using the ABZ-phase pulse train specification rotary encoder

The home position using a ABZ-phase pulse train specification rotary encoder as a load side encoder is as described below. It is the position per servo motor revolution, starting at the position where the Z-phase of the load side encoder is passed through first after power-on of the servo amplifier.

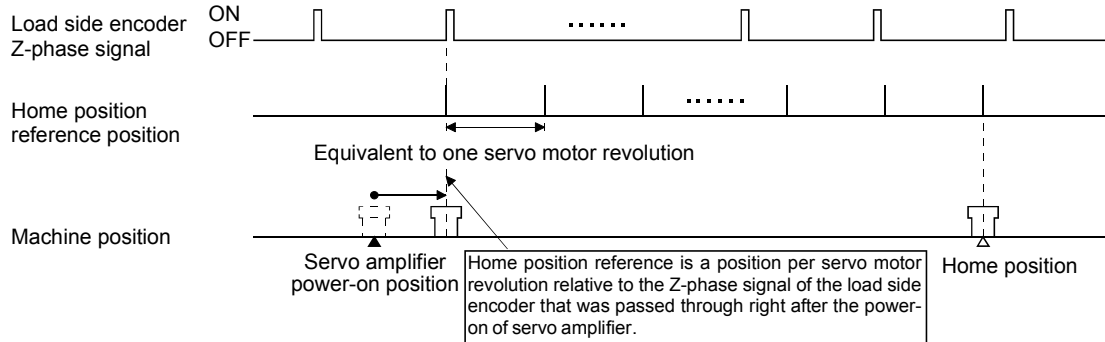

The home position reference position is set relative to the Z-phase position of the load side encoder that is passed through first after power-on of the servo amplifier.

In Case A and Case B where the power-on position differs as shown below, the power-on position must be noted since the axis cannot stop at the same home position return position.

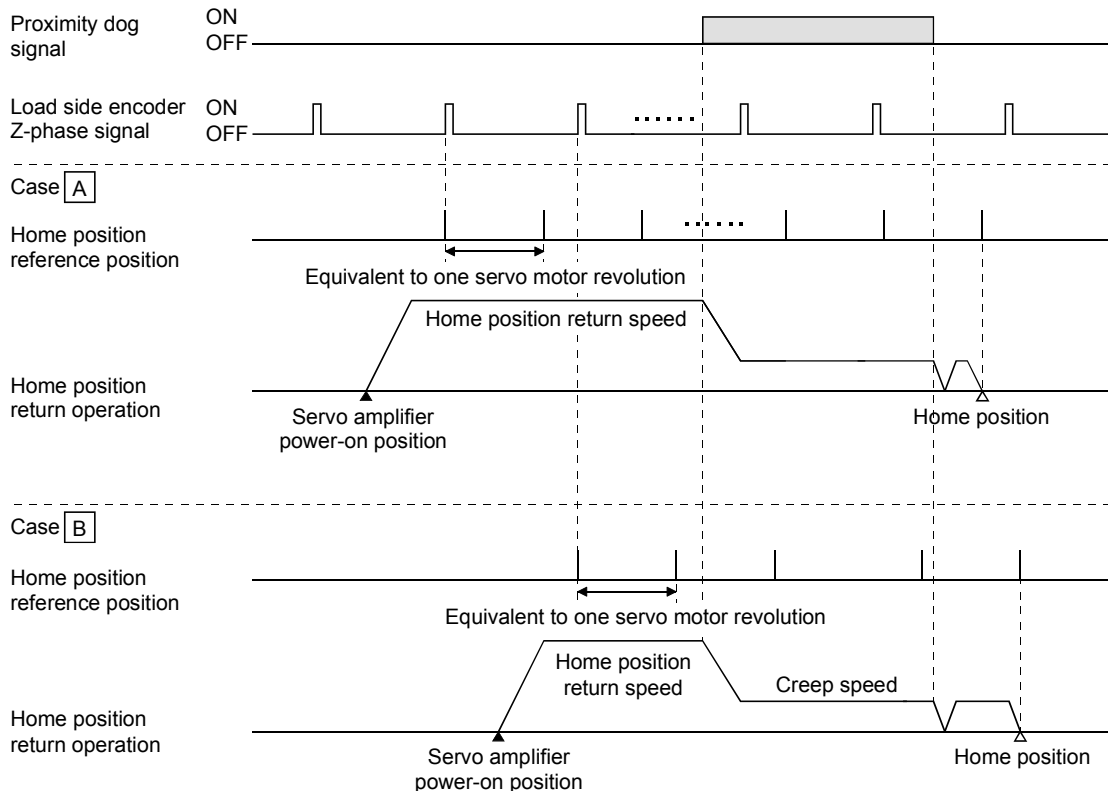

4. OPERATION AND FUNCTIONS

To always make a home position return to the same position, perform the following operation. Once move the rotary encoder to the stroke end opposite to the home position return direction with the JOG operation of controller, etc. and then perform a home position return.

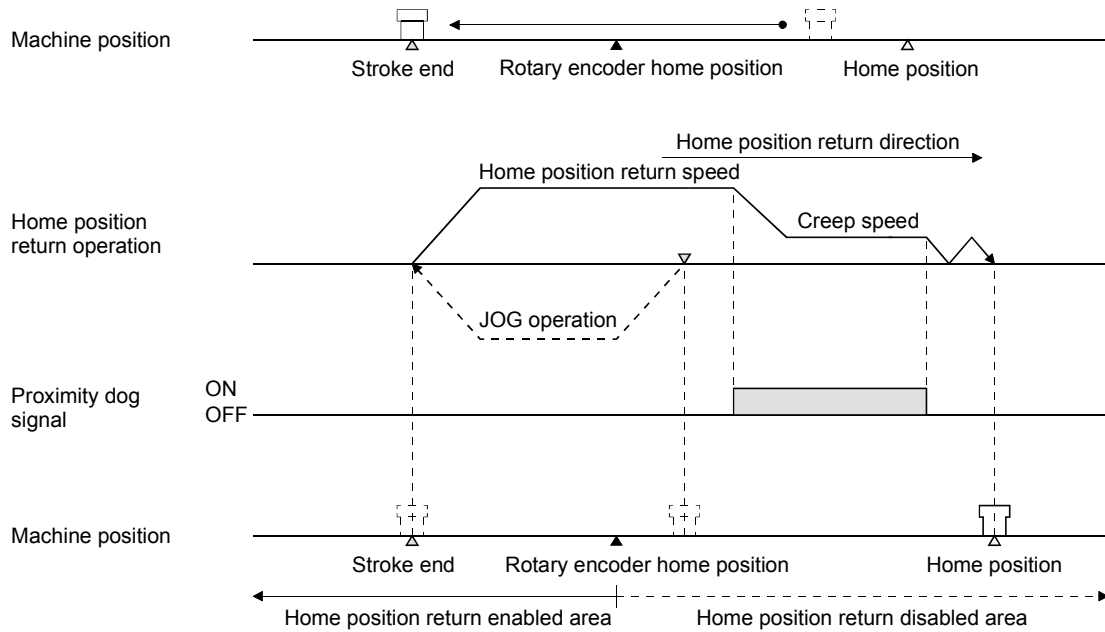

- (4) About dog type home position return when using the rotary encoder of a serial communication servo motor
 The home position for when using the rotary encoder of a serial communication servo motor for the load side encoder is at the load side Z-phase position.

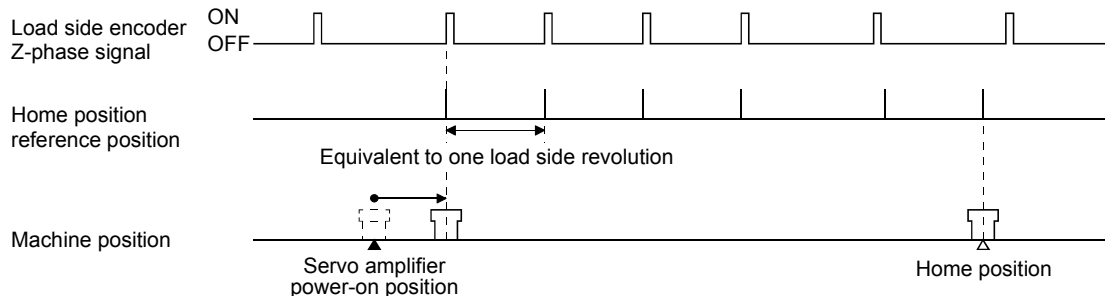

- (5) About data setting type (Common to all load side encoders)
 In the data setting type home position return method, pass through a scale home position (reference mark) and the Z-phase signal of the rotary encoder, and then make a home position return.
 When the machine has no distance of one motor encoder revolution until the Z-phase of the rotary encoder is passed through, a home position return can be made by changing the parameter No.PC17 (home position setting condition selection) setting if the home position is not yet passed through.

4. OPERATION AND FUNCTIONS

4.3 Operation from controller

The fully closed loop control compatible servo amplifier can be used with any of the following controllers.

Servo system controller	Model	Remarks
Motion controller	Q17□DCPU/ Q17□HCPU/ Q170MCPU	Speed control (II) instructions (VVF and VVR) cannot be used.
Positioning module	QD74MH□/QD75MH□	

An absolute type linear scale is required to configure an absolute position detection system.

The battery (MR-J3BAT) need not be fitted to the servo amplifier.

4.3.1 Operation from controller

Positioning operation from the controller is basically performed like the MR-J3-□B servo amplifier.

4.3.2 Servo system controller setting

When using fully closed loop system, make the following setting.

Set the other servo parameters and positioning control parameters as in the MR-J3-□B servo amplifier.

Parameter No.PA01, PC17, PC26, PC27, PE01, PE03 to PE05, PE34 and PE35 are written to the servo amplifier and then are enabled using any of the methods indicated by ○ in Parameter valid conditions.

Parameter No.PE06 to PE08 are enabled at setting regardless of the valid conditions.

Setting item		Parameter valid conditions		Settings	
		Controller reset	Power OFF→ON	Motion controller Q17□DCPU/ Q17□HCPU/ Q170MCPU	Positioning module QD74MH□/ QD75MH□
Command resolution				Load side encoder resolution unit	
MR-J3-□B-RJ006 Fully closed loop servo amplifier setting				MR-J3-B fully closed loop	
Motor setting				Automatic setting	
Servo parameters	Serial encoder cable selection (parameter No.PC26, PC27)	×	○	Set the items as required.	
	Home position setting condition selection (parameter No.PC17)	○	○		
	Fully closed loop selection (parameter No.PA01, PE01)	×	○		
	Fully closed loop selection 2 (parameter No.PE03)	○	○		
	Fully closed loop control error detection speed deviation error detection level (parameter No.PE06)	Valid at setting regardless of the valid conditions			
	Fully closed loop control error detection position deviation error detection level (parameter No.PE07)	Valid at setting regardless of the valid conditions			
	Fully closed loop electronic gear numerator (parameter No.PE04, PE34)	×	○		
	Fully closed loop electronic gear denominator (parameter No.PE05, PE35)	×	○		
	Fully closed loop dual feedback filter (parameter No.PE08)	Valid at setting regardless of the valid conditions			
	Positioning control parameters	Unit setting			
Number of pulses per revolution (AP)		For the setting methods, refer to (1) (2) in this section.			
Movement amount per revolution (AL)					

4. OPERATION AND FUNCTIONS

4.4 Functions

4.4.1 Fully closed loop control error detection

If fully closed loop control becomes unstable for some reason, the speed at servo motor side may increase abnormally.

The fully closed loop control error detection function is a protective function designed to pre-detect it and stop operation.

The fully closed loop control error detection function has two different detection methods, speed deviation and position deviation, and errors are detected only when the corresponding functions are made valid by setting Fully closed loop function selection (parameter No.PE03).

The detection level setting can be changed using the parameters (No.PE06, PE07).

(1) Parameters

The fully closed loop control error detection function is selected.

Parameter No.PE03

0	0	0	
---	---	---	--

Fully closed loop control error detection function selection
0: Invalid
1: Speed deviation error detection
2: Position deviation error detection
3: Speed deviation error/position deviation error detection

(2) Fully closed loop control error detection function

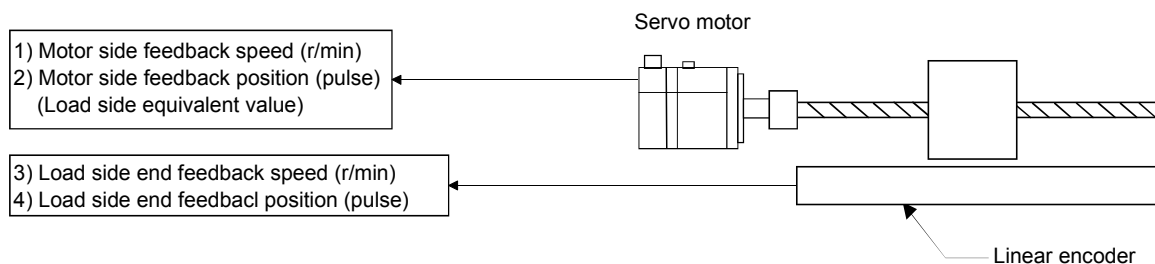

(a) Speed deviation error detection

Set "□□□1" in parameter No.PE03 to make the speed deviation error detection valid.

Parameter No.PE03

			1
--	--	--	---

Speed deviation error detection

Comparing the motor side feedback speed (1)) and load side feedback speed (3)), if the difference is not less than the set value (1 to the permissible speed r/min) of parameter No.PE06 (fully closed loop control speed deviation error detection level), the function generates an alarm (fully closed loop control error detection (42)) and stops. The initial value of parameter No.PE06 is 400r/min. Change the set value as required.

4. OPERATION AND FUNCTIONS

(b) Position deviation error detection

Set "□□□2" in parameter No.PA03 to make the position deviation error detection valid.

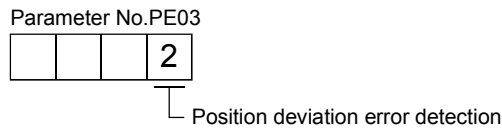

Comparing the motor side feedback position (2) and load side feedback position (4)), if the difference is not less than the set value (1 to 20000kpulse) of parameter No.PE07 (fully closed loop control position deviation error detection level), the function generates an alarm (fully closed loop control error detection (42)) and stops. The initial value of parameter No.PE07 is 100kpulse. Change the set value as required.

(c) Detecting multiple deviation errors

When setting parameter No.PE03 as shown below, multiple deviation errors can be detected. For the error detection method, refer to (a) (b) in this section.

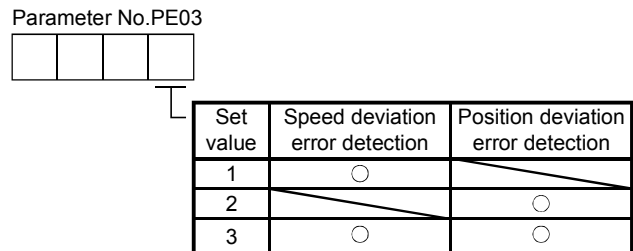

4.4.2 Auto tuning function

The auto tuning function is the same as that of the MR-J3-□B servo amplifier. For full information, refer to the MR-J3-□B Servo Amplifier Instruction Manual.

4.4.3 Machine analyzer function

The machine analyzer function of the MR Configurator is the same as that of the MR-J3-□B servo amplifier. For full information, refer to the MR-J3-□B Servo Amplifier Instruction Manual.

This function is activated by the feedback of the motor encoder. It is irrelevant to the load side encoder.

4. OPERATION AND FUNCTIONS

4.4.4 Test operation mode

Test operation can be performed by combining the MR Configurator software that runs on the personal computer and the servo amplifier.

This servo amplifier cannot use motor-less operation.

For details on the test operation, refer to the MR-J3-□B Servo Amplifier Instruction Manual.

Function	Item	Usability	Remarks
Test operation mode	Jog operation	Usable	Performed by the feedback of the motor encoder. It is irrelevant to the load side encoder.
	Positioning operation	Usable	In the setting of parameter No.PA01, the operations can be set in the motor encoder unit resolution unit or the load side encoder resolution unit.
	Program operation	Usable	In the setting of parameter No.PE01, semi closed loop control/fully closed loop control can be set. However, the semi closed loop control is always set only if parameter No.PE01 is set to "□□□1". For details, refer to section 4.1.2.
	Output signal (DO) forced output	Usable	Same as the MR-J3-□B servo amplifier function.
	Motor-less operation	Unusable	Not supported.

4.5 Absolute position detection system under fully closed loop system

POINT
<ul style="list-style-type: none"> When using a rotary encoder, the absolute position detection system cannot be configured.

An absolute type linear encoder is necessary to configure an absolute position detection system under fully closed loop control using a linear encoder.

In this case, the encoder battery (MR-J3BAT) need not be installed to the servo amplifier.

Make setting to make Absolute position detection valid in the servo parameter (Parameter No.PA03). The system can be used in the following limited conditions.

(1) Using conditions

- 1) Use an absolute type linear encoder with the load side encoder.
- 2) Select Always fully closed loop (Parameter No.PA01 = □□1□, Parameter No.PE01 = □□□0).

(2) Absolute position detection range using encoder

Encoder type	Absolute position detection enabled range
Linear encoder (Serial Interface)	Movable distance range of scale (within 32-bit absolute position data)

(3) Alarm detection

The absolute position-related alarm (25) and warnings (92, 9F) are not detected.

4. OPERATION AND FUNCTIONS

4.6 About MR Configurator

Using MR Configurator can confirm if the parameter setting is normal or if the servo motor and the load side encoder operate properly.

(1) Batch monitor display

Select "MR-J3-B fully closed loop" in the system setting of the set-up menu.

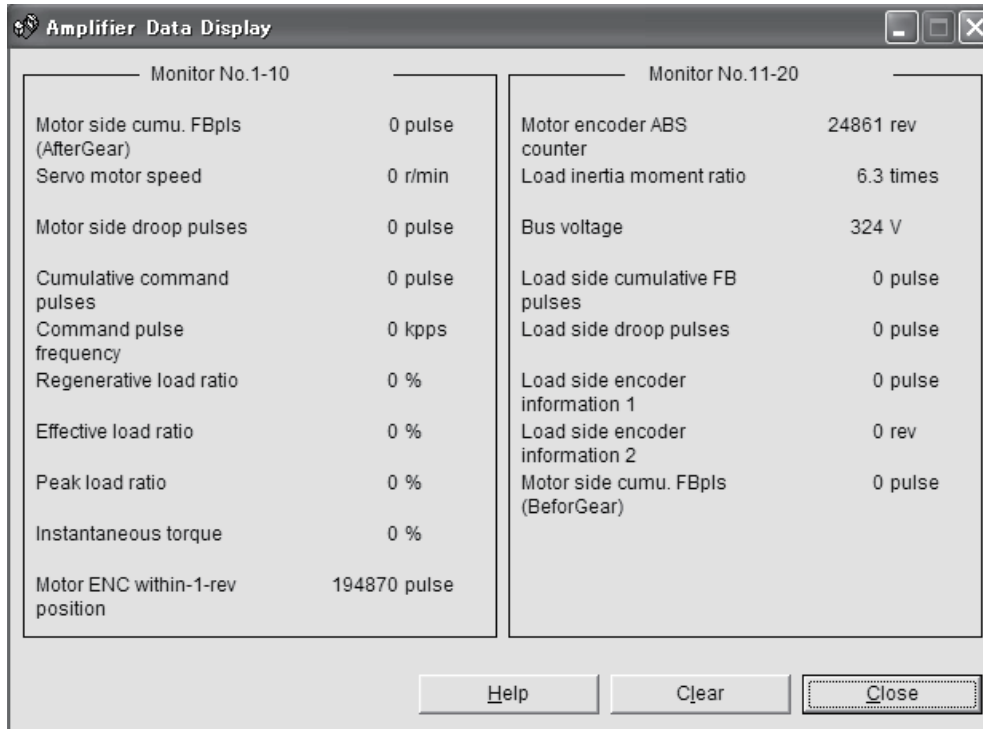

Name	Explanation	Unit
Motor side cumu. FBpls (AfterGear)	Feedback pulses from the servo motor encoder are counted and displayed. (Load side encoder unit) When the set value exceeds 999999999, it starts with 0. Click "Clear" to reset the value to 0. The "-" symbol is indicated for reverse.	pulse
Servo motor speed	The servo motor speed is displayed. It is displayed rounding off 0.1r/min unit. The "-" symbol is indicated for reverse.	r/min
Motor side droop pulses	Droop pulses of the deviation counter between a motor side position and a command are displayed. The "-" symbol is indicated for reverse.	pulse
Cumulative command pulses	Position command input pulses are counted and displayed. Click "Clear" to reset the value to 0. The "-" symbol is indicated for reverse command.	pulse
Command pulse frequency	The frequency of position command input pulses is counted and displayed. The "-" symbol is indicated for reverse command.	kpps
Regenerative load ratio	The proportion of regenerative powers to permissive regenerative powers is indicated in percentage. Permissive regenerative powers differ according to the absence or presence of a regenerative option. Set parameter No.PA02 correctly according to the regenerative option.	%
Effective load ratio	The continuous effective load torque is displayed. The effective value is displayed considering a rated torque as 100%.	%

4. OPERATION AND FUNCTIONS

Name	Explanation	Unit
Peak load ratio	The maximum occurrence torque is displayed. The maximum value for the past 15 seconds is displayed considering a rated torque as 100%.	%
Instantaneous torque	The instantaneous occurrence torque is displayed. The value of torque being occurred is displayed in real time considering a rated torque as 100%.	%
Motor ENC within-1-rev position	The position in servo motor side 1-revolution is displayed in the encoder pulse unit. When the value exceeds the maximum number of pulses, it resets to 0. When the servo motor rotates in the CCW direction, the value is added.	pulse
Motor encoder ABS counter	The movement amount from the home position (0) is displayed as multi-revolution counter value of the absolute position encoder in the absolute position detection system.	rev
Load inertia moment ratio	The estimated value of the servo motor shaft conversion load inertia moment ratio to the servo motor inertia moment is displayed.	Multiplier (× 1)
Bus voltage	The voltage (across P(+)-N(-)) of main circuit converter is displayed.	V
Load side cumulative FB pulses	Feedback pulses from the load side encoder are counted and displayed. When the set value exceeds 999999999, it starts with 0. Click "Clear" to reset the value to 0. The "-" symbol is indicated for reverse.	pulse
Load side droop pulses	Droop pulses of the deviation counter between a load side position and a command are displayed. The "-" symbol is indicated for reverse.	pulse
Load side encoder information 1	The position in load side encoder 1-revolution is displayed. For an incremental linear scale, the Z-phase counter is displayed. The value is counted up from 0 based on the home position (reference mark). It is displayed in load side encoder pulse unit. For an absolute position linear scale, the encoder absolute position is displayed.	pulse
Load side encoder information 2	Multi-revolution counter of the load side encoder is displayed. (for using a rotary encoder)	rev
Motor side cumu. FBpls (BeforeGear)	Feedback pulses from the servo motor encoder are counted and displayed. (Motor encoder unit) When the set value exceeds 999999999, it starts with 0. Click "Clear" to reset the value to 0. The "-" symbol is indicated for reverse.	pulse

4. OPERATION AND FUNCTIONS

(2) Fully closed loop diagnostic screen

Select the fully closed loop diagnostics of the diagnostics menu.

Click "Monitor start" to constantly read the monitor display items from the servo amplifier.

Then, click "Monitor stop" to stop reading.

Click "Parameter read" to read the parameter items from the servo amplifier, and then click "Parameter write" to write them.

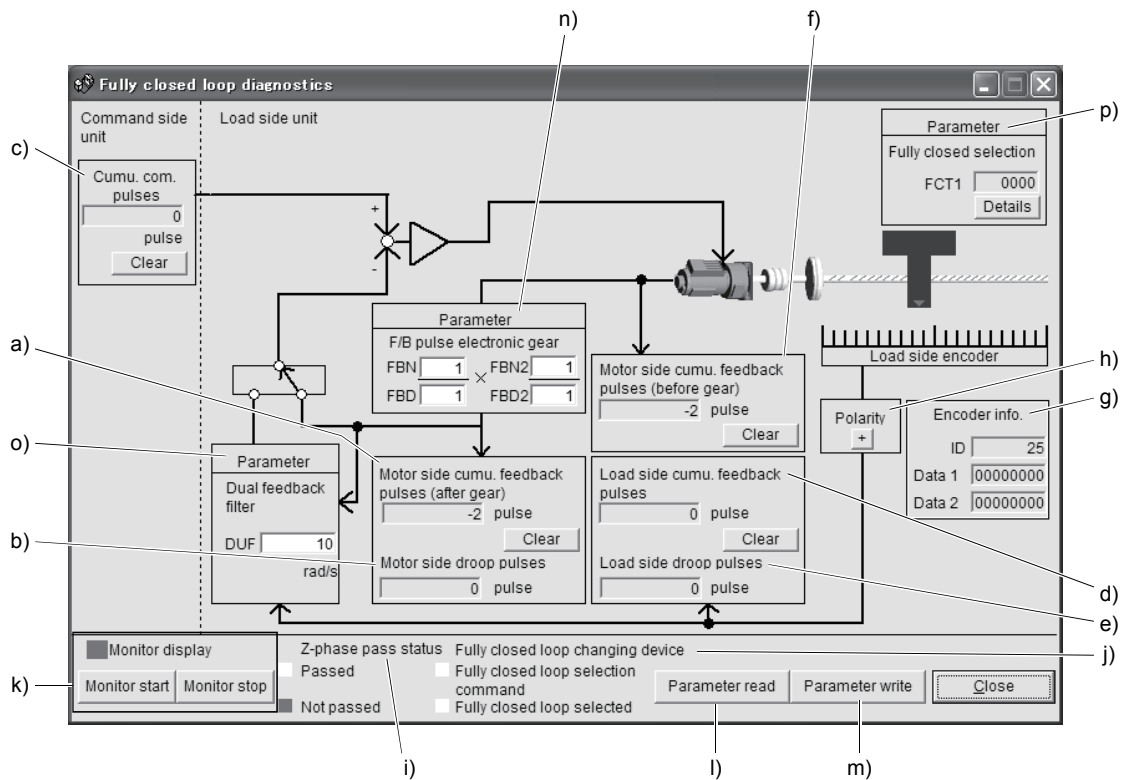

Symbol	Name	Explanation	Unit
a)	Motor side cumu. feedback pulses (after gear)	Feedback pulses from the servo motor encoder are counted and displayed. (Load side encoder unit) When the set value exceeds 999999999, it starts with 0. Click "Clear" to reset the value to 0. The "-" symbol is indicated for reverse.	pulse
b)	Motor side droop pulses	Droop pulses of the deviation counter between a motor side position and a command are displayed. The "-" symbol is indicated for reverse.	pulse
c)	Cumu. Com. pulses	Position command input pulses are counted and displayed. Click "Clear" to reset the value to 0. The "-" symbol is indicated for reverse command.	pulse
d)	Load side cumu. feedback pulses	Feedback pulses from the load side encoder are counted and displayed. When the set value exceeds 999999999, it starts with 0. Click "Clear" to reset the value to 0. The "-" symbol is indicated for reverse.	Pulse
e)	Load side droop pulses	Droop pulses of the deviation counter between a load side position and a command are displayed. The "-" symbol is indicated for reverse.	Pulse
f)	Motor side cumu. feedback pulses (before gear)	Feedback pulses from the servo motor encoder are counted and displayed. (Motor encoder unit) When the set value exceeds 999999999, it starts with 0. Click "Clear" to reset the value to 0. The "-" symbol is indicated for reverse.	pulse

4. OPERATION AND FUNCTIONS

Symbol	Name	Explanation	Unit
g)	Encoder information	The load side encoder information is displayed. The display contents differ depending on the load side encoder type. <ul style="list-style-type: none"> ▪ ID: The ID No. of the load side encoder is displayed. ▪ Data 1: For the incremental type linear encoder, the counter from powering ON is displayed. For the absolute position type linear encoder, the absolute position data is displayed. ▪ Data 2: For the incremental type linear encoder, the distance (number of pulses) from the reference mark (Z-phase) is displayed. For the absolute position type linear encoder, "00000000" is displayed. 	
h)	Polarity	A polarity is indicated as "+" or "-" according to the load side encoder polarity specified in parameter No.PC27. For address increasing direction in the motor CCW, it is indicated as "+" and for address decreasing direction in the motor CCW, as "-".	
i)	Z-phase pass status	If the fully closed loop system is "Invalid", the Z-phase pass status of the motor encoder is displayed. If the fully closed loop system is "Valid" or "Semi closed loop control/fully closed loop control switching", the Z-phase pass status of the load side encoder is displayed.	
j)	Fully closed loop changing device	Only if the fully closed loop system is "Semi closed loop control/fully closed loop control switching", the device is displayed. The state of the semi closed loop control/fully closed loop control switching bit and the inside state during selection are displayed.	
k)	Monitor display	Click the "Monitor start" button to start monitoring. Click the "Monitor stop" button to stop monitoring.	
l)	Parameter read	Click the "Parameter read" button to read all the parameter settings that can be set and displayed on this window from the servo amplifier and display them.	
m)	Parameter write	Click the "Parameter write" button to write the all parameter settings set and displayed on this window to the servo amplifier.	
n)	Parameter (Feedback pulse electronic gear)	The feedback pulse electronic gears (parameter No.PE04, PE05, PE34, PE35) are displayed/set for motor encoder pulses in this parameter. (Refer to section 4.1.5.) For details of each parameter, refer to section 5.5.2.	
o)	Parameter (Dual feedback filter)	The band of dual feedback filter (parameter No.PE08) is displayed/set in this parameter. For details of parameter, refer to section 5.5.2.	

4. OPERATION AND FUNCTIONS

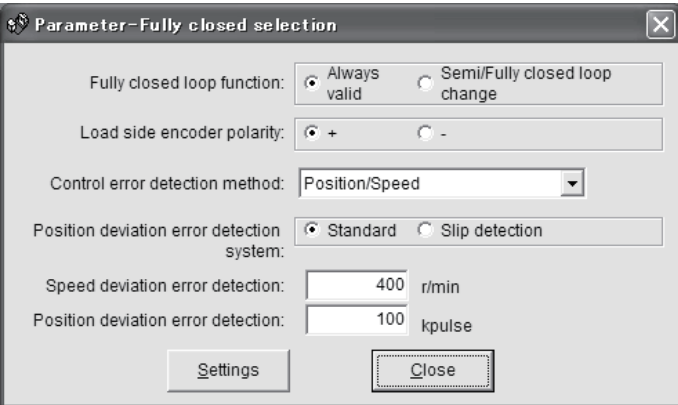
Symbol	Name	Explanation	Unit
p)	Parameter (fully closed loop selection)	<p>The parameter for the fully closed loop control is displayed/set. Click "Details" button to display the "Parameter – Fully closed selection" window.</p>  <ol style="list-style-type: none"> 1) Fully closed loop function (Parameter No.PE01) Select "Always valid" or "Semi/Fully closed loop change" for the fully closed loop control function. 2) Load side encoder polarity (Parameter No.PC27) Select "+" (encoder pulse increasing direction in the servo motor CCW) or "-" (encoder pulse decreasing direction in the servo motor CCW) for the encoder pulse count polarity. 3) Control error detection method (Parameter No.PE03) Select "Invalid", "Speed (speed deviation error detection)", "Position (position deviation error detection)" or "Position/Speed (position deviation error/speed deviation error)" for the fully closed loop control error detection function. 4) Position deviation error detection system (Parameter No.PE03) Select "Standard (always position deviation detection system)" or "Slip detection (stopping position deviation detection system)" for a detection condition regarding the fully closed loop control error and the position deviation error of the detection function. 5) Speed deviation error detection (Parameter No.PE06) Set the speed deviation error detection level to be used in the fully closed loop control error detection function. 6) Position deviation error detection (Parameter No.PE07) Set the position deviation error detection level to be used in the fully closed loop control error detection function. <p>For details of each parameter, refer to section 5.3.2 and 5.5.2. Click "Settings" to set the functions. Click "Close" to close the window.</p>	

5. PARAMETERS

5. PARAMETERS



CAUTION

- Never adjust or change the parameter values extremely as it will make operation instable.

POINT

- This chapter describes the parameters unique to the fully closed loop control compatible servo amplifier MR-J3-□B-RJ006. For the same parameters as those of MR-J3-□B servo amplifier, refer to chapter 5 of the MR-J3-□B Servo Amplifier Instruction Manual.

In this servo amplifier, the parameters are classified into the following groups on a function basis.

Parameter group	Main description
Basic setting parameters (No.PA□□)	When using this servo amplifier in the position control mode, make basic setting with these parameters.
Gain/filter parameters (No.PB□□)	Use these parameters when making gain adjustment manually.
Extension setting parameters (No.PC□□)	Use these parameters when changing settings such as analog monitor output signal or electromagnetic brake sequence output.
I/O setting parameters (No.PD□□)	Use these parameters when changing the I/O signals of the servo amplifier.
Extension control parameters (No.PE□□)	Use these parameters when selecting a function in the fully closed loop system.

When using this servo in the position control mode, mainly setting the basic setting parameters (No.PA□□) allows the setting of the basic parameters at the time of introduction.

5.1 Basic setting parameters (No.PA□□)

POINT

- Parameter whose symbol is preceded by * is made valid with the following conditions.
 - * : Set the parameter value, switch power off once after setting, and then switch it on again, or perform the controller reset.
 - ** : Set the parameter value, switch power off once, and then switch it on again.
- Never change parameters for manufacturer setting.

5. PARAMETERS

5.1.1 Parameter list

No.	Symbol	Name	Initial value	Unit	Reference
PA01	**STY	Control mode	0000h		Section 5.1.3
PA02	**REG	Regenerative option	0000h		Chapter 5 of the MR-J3-□B Servo Amplifier Instruction Manual
PA03	*ABS	Absolute position detection system	0000h		Section 5.1.4
PA04	*AOP1	Function selection A-1	0000h		Chapter 5 of the MR-J3-□B Servo Amplifier Instruction Manual
PA05		For manufacturer setting	0		
PA06			1		
PA07			1		
PA08	ATU	Auto tuning	0001h		Chapter 5 of the MR-J3-□B Servo Amplifier Instruction Manual
PA09	RSP	Auto tuning response	12		
PA10	INP	In-position range	100	pulse	Section 5.1.5
PA11		For manufacturer setting	1000.0	%	
PA12			1000.0	%	
PA13			0000h		
PA14	*POL	Rotation direction selection	0		Chapter 5 of the MR-J3-□B Servo Amplifier Instruction Manual
PA15	*ENR	Encoder output pulses	4000	pulse/rev	Section 5.1.6
PA16	*ENR2	Encoder output pulses 2	0		
PA17		For manufacturer setting	0000h		
PA18			0000h		
PA19	*BLK	Parameter write inhibit	000Fh		Chapter 5 of the MR-J3-□B Servo Amplifier Instruction Manual

5. PARAMETERS

5.1.2 Parameter write inhibit

Parameter			Initial value	Unit	Setting range
No.	Symbol	Name			
PA19	*BLK	Parameter write inhibit	000Fh		Refer to the text.

POINT
<ul style="list-style-type: none"> This parameter is made valid when power is switched off, then on after setting, or when the controller reset has been performed.

In the factory setting, this servo amplifier allows changes to the basic setting parameter, gain/filter parameter, extension setting parameter, I/O setting parameter and extension control parameter settings. With the setting of parameter No.PA19, write can be disabled to prevent accidental changes.

The following table indicates the parameters which are enabled for reference and write by the setting of parameter No.PA19. Operation can be performed for the parameters marked ○.

Parameter No. PA19 setting	Setting operation	Basic setting parameters No.PA□□	Gain/Filter parameters No.PB□□	Extension setting parameters No.PC□□	I/O setting parameters No.PD□□	Extension control parameters No.PE□□
0000h	Reference	○				
	Write	○				
000Bh	Reference	○	○	○		
	Write	○	○	○		
000Ch	Reference	○	○	○	○	
	Write	○	○	○	○	
000Fh (initial value)	Reference	○	○	○	○	○
	Write	○	○	○	○	○
100Bh	Reference	○				
	Write	Parameter No. PA19 only				
100Ch	Reference	○	○	○	○	○
	Write	Parameter No. PA19 only				

5. PARAMETERS

5.1.3 Selecting a control mode

Parameter			Initial value	Unit	Setting range
No.	Symbol	Name			
PA01	**STY	Control mode	0000h		Refer to the text.

POINT
<ul style="list-style-type: none"> This parameter value and switch power off once, then switch it on again to make that parameter setting valid.

Select a control mode.

The initial value of this parameter is set to "□□0□" (semi closed loop system).

When using the fully closed loop system, make sure to set the value to "□□1□". In this case, the value can be set to the fully closed loop system by the parameter No.PE01 setting and the semi closed loop system/fully closed loop system switching bit of the controller command. (Refer to section 1.5.)

Parameter No.PA01

0	0	□	0
---	---	---	---

Control mode selection
 0: Semi closed loop system
 1: Fully closed loop system

5.1.4 Using absolute position detection system

Parameter			Initial value	Unit	Setting range
No.	Symbol	Name			
PA03	*ABS	Absolute position detection system	0000h		Refer to the text.

POINT
<ul style="list-style-type: none"> This parameter is made valid when power is switched off, then on after setting, or when the controller reset has been performed. This parameter cannot be used in the speed control mode.

Set this parameter when using the absolute position detection system in the position control mode.

Parameter No.PA03

0	0	0	□
---	---	---	---

Selection of absolute position detection system (refer to chapter 12 of the MR-J3-□B Servo Amplifier Instruction Manual)
 0: Used in incremental system
 1: Used in absolute position detection system
 In the following cases, the parameter error (37) occurs, and absolute position detecting system cannot be used.

- Linear encoder of incremental type is used.
- Switching between semi closed/fully closed loop system is set valid.

5. PARAMETERS

5.1.5 In-position range

Parameter			Initial value	Unit	Setting range
No.	Symbol	Name			
PA10	INP	In-position range	100	pulse	0 to 65535

POINT
▪ This parameter cannot be used in the speed control mode.

Set the range, where In position (INP) is output, in the command pulse unit.

For the semi closed loop system, set it in the motor encoder unit. For the fully closed loop system, set it in the load side encoder unit.

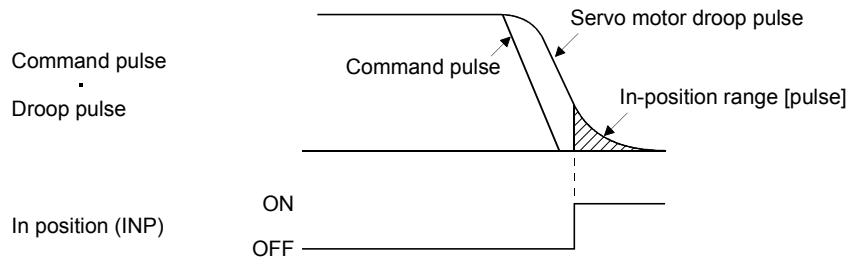

5.1.6 Encoder output pulse

Parameter			Initial value	Unit	Setting range
No.	Symbol	Name			
PA15	*ENR	Encoder output pulse	4000	pulse/rev	1 to 65535
PA16	*ENR2	Encoder output pulse 2	0		0 to 65535

POINT
▪ This parameter is made valid when power is switched off, then on after setting, or when the controller reset has been performed.

Used to set the encoder pulses (A-phase, B-phase) output by the servo amplifier.

Set the value 4 times greater than the A-phase, B-phase pulses.

You can use parameter No.PC03 to choose the output pulse setting or output division ratio setting.

The number of A · B-phase pulses actually output is 1/4 times greater than the preset number of pulses.

The maximum output frequency is 4.6Mpps (after multiplication by 4). Use this parameter within this range.

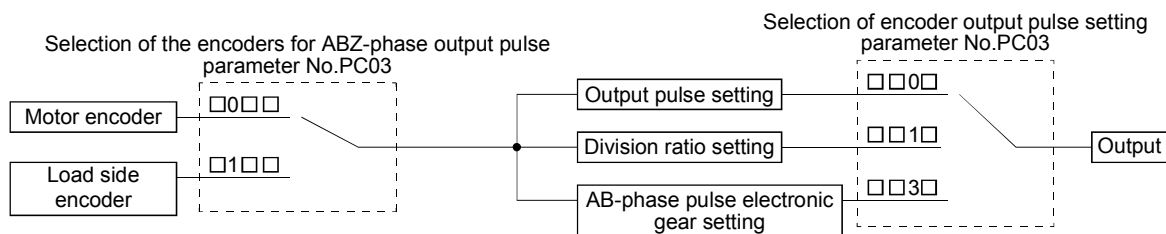

5. PARAMETERS

(1) For output pulse designation

Set "□□0□" (initial value) in parameter No.PC03. When parameter No.PC03 has been set to "□1□□", the parameter error (37) occurs.

Set the number of pulses per servo motor revolution.

Output pulse = set value [pulses/rev]

For instance, set "5600" to Parameter No.PA15, the actually A · B-phase output pulses are as indicated below.

$$A \cdot B\text{-phase output pulses} = \frac{5600}{4} = 1400[\text{pulse}]$$

(2) For output division ratio setting

Set "□□1□" in parameter No.PC03.

The number of pulses per servo motor revolution is divided by the set value.

$$\text{Output pulse} = \frac{\text{Resolution per servo motor revolution}}{\text{Set value}} [\text{pulses/rev}]$$

For instance, set "8" to Parameter No.PA15, the actually output A/B-phase pulses are as indicated below.

$$A \cdot B\text{-phase output pulses} = \frac{262144}{8} \cdot \frac{1}{4} = 8192[\text{pulse}]$$

(3) For output electronic gear ratio setting

Set "□□3□" in parameter No.PC03.

The resolution per servo motor revolution is set by parameter No.PA15, PA16.

$$\text{Output pulse} = \text{Resolution per servo motor revolution} \times \frac{\text{Set value of parameter No.PA15}}{\text{Set value of parameter No.PA16}} [\text{pulses/rev}]$$

For instance, set "3" to Parameter No.PA15 and "32" to Parameter No.PA16, the actually A · B-phase output pulses are as indicated below.

$$A \cdot B\text{-phase output pulses} = 262144 \times \frac{3}{32} \times \frac{1}{4} = 6144 [\text{pulse}]$$

5. PARAMETERS

5.2 Gain/filter parameters (No.PB□□)

POINT
<ul style="list-style-type: none"> The gain/filter parameter (No.PB□□) is the same as that of MR-J3□B servo amplifier. For details, refer to the MR-J3-□B Servo Amplifier Instruction Manual. Parameter whose symbol is preceded by * is made valid with the following conditions.
<p>* : Set the parameter value, switch power off once after setting, and then switch it on again, or perform the controller reset.</p>

No.	Symbol	Name	Initial value	Unit	Reference
PB01	FILT	Adaptive tuning mode (Adaptive filter II)	0000h		Chapter 5 of the MR-J3-□B Servo Amplifier Instruction Manual
PB02	VRFT	Vibration suppression control tuning mode (Advanced vibration suppression control)	0000h		
PB03		For manufacturer setting	0		
PB04	FFC	Feed forward gain	0	%	
PB05		For manufacturer setting	500		
PB06	GD2	Ratio of load inertia moment to servo motor inertia moment	7.0	Multi- plier (× 1)	
PB07	PG1	Model loop gain	24	rad/s	
PB08	PG2	Position loop gain	37	rad/s	
PB09	VG2	Speed loop gain	823	rad/s	
PB10	VIC	Speed integral compensation	33.7	ms	
PB11	VDC	Speed differential compensation	980		
PB12		For manufacturer setting	0		
PB13	NH1	Machine resonance suppression filter 1	4500	Hz	
PB14	NHQ1	Notch shape selection 1	0000h		
PB15	NH2	Machine resonance suppression filter 2	4500	Hz	
PB16	NHQ2	Notch shape selection 2	0000h		
PB17		Automatic setting parameter			
PB18	LPF	Low-pass filter setting	3141	rad/s	
PB19	VRF1	Vibration suppression control vibration frequency setting	100.0	Hz	
PB20	VRF2	Vibration suppression control resonance frequency setting	100.0	Hz	
PB21		For manufacturer setting	0.00		
PB22			0.00		
PB23	VFBF	Low-pass filter selection	0000h		
PB24	*MVS	Slight vibration suppression control selection	0000h		
PB25		For manufacturer setting	0000h		
PB26	*CDP	Gain changing selection	0000h		
PB27	CDL	Gain changing condition	10		
PB28	CDT	Gain changing time constant	1	ms	
PB29	GD2B	Gain changing ratio of load inertia moment to servo motor inertia moment	7.0	Multi- plier (× 1)	
PB30	PG2B	Gain changing position loop gain	37	rad/s	
PB31	VG2B	Gain changing speed loop gain	823	rad/s	
PB32	VICB	Gain changing speed integral compensation	33.7	ms	
PB33	VRF1B	Gain changing vibration suppression control vibration frequency setting	100.0	Hz	
PB34	VRF2B	Gain changing vibration suppression control resonance frequency setting	100.0	Hz	
PB35		For manufacturer setting	0.00		
PB36			0.00		
PB37			100		
PB38			0.0		
PB39			0.0		

5. PARAMETERS

No.	Symbol	Name	Initial value	Unit	Reference
PB40		For manufacturer setting	0.0		Chapter 5 of the MR-J3-□B Servo Amplifier Instruction Manual
PB41			1125		
PB42			1125		
PB43			0004h		
PB44			0.0		
PB45			0000h		

5. PARAMETERS

5.3 Extension setting parameters (No.PC□□)

POINT
<ul style="list-style-type: none"> ▪ Parameter whose symbol is preceded by * is made valid with the following conditions. * : Set the parameter value, switch power off once after setting, and then switch it on again, or perform the controller reset. ** : Set the parameter value, switch power off once, and then switch it on again.

5.3.1 Parameter list

No.	Symbol	Name	Initial value	Unit	Reference
PC01	ERZ	Error excessive alarm level	3	rev	Chapter 5 of the MR-J3-□B Servo Amplifier Instruction Manual
PC02	MBR	Electromagnetic brake sequence output	0	ms	
PC03	*ENRS	Encoder output pulses selection	0000h		Section 5.3.2
PC04	**COP1	Function selection C-1	0000h		Chapter 5 of the MR-J3-□B Servo Amplifier Instruction Manual
PC05	**COP2	Function selection C-2	0000h		
PC06	*COP3	Function selection C-3	0000h		
PC07	ZSP	Zero speed	50	r/min	Chapter 5 of the MR-J3-□B Servo Amplifier Instruction Manual
PC08		For manufacturer setting	0		
PC09	MOD1	Analog monitor output 1	0000h		Section 5.3.2
PC10	MOD2	Analog monitor output 2	0001h		
PC11	MO1	Analog monitor 1 offset	0	mV	Chapter 5 of the MR-J3-□B Servo Amplifier Instruction Manual
PC12	MO2	Analog monitor 2 offset	0	mV	
PC13		For manufacturer setting	0		
PC14			0		
PC15			0		
PC16			0000h		
PC17	**COP4	Function selection C-4	0000h		Chapter 5 of the MR-J3-□B Servo Amplifier Instruction Manual
PC18		For manufacturer setting	0000h		
PC19			0000h		
PC20	*COP7	Function selection C-7	0000h		Chapter 5 of the MR-J3-□B Servo Amplifier Instruction Manual
PC21	*BPS	Alarm history clear	0000h		
PC22		For manufacturer setting	0000h		
PC23			0000h		
PC24			0000h		
PC25			0000h		
PC26	**COP8	Function selection C-8	0100h		Section 5.3.2
PC27	**COP9	Function selection C-9	0000h		
PC28		For manufacturer setting	0000h		
PC29			0000h		
PC30			0000h		
PC31			0000h		
PC32			0000h		

5. PARAMETERS

5.3.2 List of details

No.	Symbol	Name and function	Initial value	Unit	Setting range																										
PC03	*ENRS	<p>Encoder output pulse selection</p> <p>Use to select the, encoder output pulse direction and encoder output pulse setting.</p> <div style="border: 1px solid black; padding: 5px; margin: 10px 0;"> <table border="1" style="display: inline-table; border-collapse: collapse;"> <tr> <td style="width: 20px; text-align: center;">0</td> <td style="width: 20px;"></td> <td style="width: 20px;"></td> <td style="width: 20px;"></td> </tr> </table> <p style="margin-top: 5px;">Encoder output pulse phase changing Changes the phases of A · B-phase encoder output pulses.</p> <table border="1" style="display: inline-table; border-collapse: collapse; text-align: center;"> <thead> <tr> <th rowspan="2">Set value</th> <th colspan="2">Servo motor rotation direction</th> </tr> <tr> <th>CCW</th> <th>CW</th> </tr> </thead> <tbody> <tr> <td>0</td> <td>A-phase B-phase </td> <td>A-phase B-phase </td> </tr> <tr> <td>1</td> <td>A-phase B-phase </td> <td>A-phase B-phase </td> </tr> </tbody> </table> <p style="margin-top: 5px;">Encoder output pulse setting selection (Note) 0: Output pulse designation (When parameter No.PC03 is set to "□1□□", the parameter error (37) occurs.) 1: Division ratio setting 3: AB-phase pulse electronic gear setting (The electronic gear is set in parameter No.PA15, PA16.)</p> <p style="margin-top: 5px;">Selection of the encoders for ABZ-phase output pulse (Note)</p> <table border="1" style="display: inline-table; border-collapse: collapse; text-align: center; margin-top: 10px;"> <thead> <tr> <th rowspan="2">Set value</th> <th colspan="2">Control mode</th> </tr> <tr> <th>Semi closed loop system (□□0□ in parameter No.PA01)</th> <th>Fully closed loop system (□□1□ in parameter No.PA01)</th> </tr> </thead> <tbody> <tr> <td>0 (Motor encoder)</td> <td colspan="2">Motor encoder (in the motor encoder unit)</td> </tr> <tr> <td>1 (Load side encoder)</td> <td>Parameter error (37)</td> <td>Load side encoder (in the load side encoder unit)</td> </tr> </tbody> </table> </div>	0				Set value	Servo motor rotation direction		CCW	CW	0	A-phase B-phase	A-phase B-phase	1	A-phase B-phase	A-phase B-phase	Set value	Control mode		Semi closed loop system (□□0□ in parameter No.PA01)	Fully closed loop system (□□1□ in parameter No.PA01)	0 (Motor encoder)	Motor encoder (in the motor encoder unit)		1 (Load side encoder)	Parameter error (37)	Load side encoder (in the load side encoder unit)	0000h		Refer to Name and function column.
0																															
Set value	Servo motor rotation direction																														
	CCW	CW																													
0	A-phase B-phase	A-phase B-phase																													
1	A-phase B-phase	A-phase B-phase																													
Set value	Control mode																														
	Semi closed loop system (□□0□ in parameter No.PA01)	Fully closed loop system (□□1□ in parameter No.PA01)																													
0 (Motor encoder)	Motor encoder (in the motor encoder unit)																														
1 (Load side encoder)	Parameter error (37)	Load side encoder (in the load side encoder unit)																													

Note. For details, refer to section 5.1.6.

5. PARAMETERS

No.	Symbol	Name and function	Initial value	Unit	Setting range																																										
PC09	MOD1	<p>Analog monitor 1 output Used to selection the signal provided to the analog monitor 1 (MO1) output. (Refer to section 5.3.3)</p> <div style="border: 1px solid black; display: inline-block; padding: 2px;"> <table border="1" style="border-collapse: collapse;"> <tr> <td style="width: 20px; text-align: center;">0</td> <td style="width: 20px; text-align: center;">0</td> <td style="width: 20px;"></td> <td style="width: 20px;"></td> </tr> </table> </div> <p style="margin-left: 40px;">└─ Analog monitor 1 (MO1) output selection</p> <table border="1" style="border-collapse: collapse; margin-left: 40px;"> <thead> <tr> <th style="width: 30px;">Setting</th> <th>Item</th> </tr> </thead> <tbody> <tr><td>00</td><td>Servo motor speed ($\pm 8V/\text{max. speed}$)</td></tr> <tr><td>01</td><td>Torque ($\pm 8V/\text{max. torque}$)</td></tr> <tr><td>02</td><td>Servo motor speed ($+8V/\text{max. speed}$)</td></tr> <tr><td>03</td><td>Torque ($+8V/\text{max. torque}$)</td></tr> <tr><td>04</td><td>Current command ($\pm 8V/\text{max. current command}$)</td></tr> <tr><td>05</td><td>Speed command ($\pm 8V/\text{max. speed}$) Speed conversion of command pulse for position control, speed command for speed control, and no output for torque control</td></tr> <tr><td>06</td><td>Motor side droop pulses ($\pm 10V/100$ pulses) (Note)</td></tr> <tr><td>07</td><td>Motor side droop pulses ($\pm 10V/1000$ pulses) (Note)</td></tr> <tr><td>08</td><td>Motor side droop pulses ($\pm 10V/10000$ pulses) (Note)</td></tr> <tr><td>09</td><td>Motor side droop pulses ($\pm 10V/100000$ pulses) (Note)</td></tr> <tr><td>0D</td><td>Bus voltage ($\pm 8V/400V$)</td></tr> <tr><td>10</td><td>Load side droop pulses ($\pm 10V/100$ pulses) (Note)</td></tr> <tr><td>11</td><td>Load side droop pulses ($\pm 10V/1000$ pulses) (Note)</td></tr> <tr><td>12</td><td>Load side droop pulses ($\pm 10V/10000$ pulses) (Note)</td></tr> <tr><td>13</td><td>Load side droop pulses ($\pm 10V/100000$ pulses) (Note)</td></tr> <tr><td>14</td><td>Load side droop pulses ($\pm 10V/1000000$ pulses) (Note)</td></tr> <tr><td>15</td><td>Motor side · load side position deviation ($\pm 10V/100000$ pulses)</td></tr> <tr><td>16</td><td>Motor side · load side speed deviation ($\pm 8V/\text{Max.speed}$)</td></tr> </tbody> </table> <p>Note. Output in the load side encoder unit for the fully closed loop control and in the motor encoder unit for the semi closed loop control.</p>	0	0			Setting	Item	00	Servo motor speed ($\pm 8V/\text{max. speed}$)	01	Torque ($\pm 8V/\text{max. torque}$)	02	Servo motor speed ($+8V/\text{max. speed}$)	03	Torque ($+8V/\text{max. torque}$)	04	Current command ($\pm 8V/\text{max. current command}$)	05	Speed command ($\pm 8V/\text{max. speed}$) Speed conversion of command pulse for position control, speed command for speed control, and no output for torque control	06	Motor side droop pulses ($\pm 10V/100$ pulses) (Note)	07	Motor side droop pulses ($\pm 10V/1000$ pulses) (Note)	08	Motor side droop pulses ($\pm 10V/10000$ pulses) (Note)	09	Motor side droop pulses ($\pm 10V/100000$ pulses) (Note)	0D	Bus voltage ($\pm 8V/400V$)	10	Load side droop pulses ($\pm 10V/100$ pulses) (Note)	11	Load side droop pulses ($\pm 10V/1000$ pulses) (Note)	12	Load side droop pulses ($\pm 10V/10000$ pulses) (Note)	13	Load side droop pulses ($\pm 10V/100000$ pulses) (Note)	14	Load side droop pulses ($\pm 10V/1000000$ pulses) (Note)	15	Motor side · load side position deviation ($\pm 10V/100000$ pulses)	16	Motor side · load side speed deviation ($\pm 8V/\text{Max.speed}$)	0000h		Refer to Name and function column.
0	0																																														
Setting	Item																																														
00	Servo motor speed ($\pm 8V/\text{max. speed}$)																																														
01	Torque ($\pm 8V/\text{max. torque}$)																																														
02	Servo motor speed ($+8V/\text{max. speed}$)																																														
03	Torque ($+8V/\text{max. torque}$)																																														
04	Current command ($\pm 8V/\text{max. current command}$)																																														
05	Speed command ($\pm 8V/\text{max. speed}$) Speed conversion of command pulse for position control, speed command for speed control, and no output for torque control																																														
06	Motor side droop pulses ($\pm 10V/100$ pulses) (Note)																																														
07	Motor side droop pulses ($\pm 10V/1000$ pulses) (Note)																																														
08	Motor side droop pulses ($\pm 10V/10000$ pulses) (Note)																																														
09	Motor side droop pulses ($\pm 10V/100000$ pulses) (Note)																																														
0D	Bus voltage ($\pm 8V/400V$)																																														
10	Load side droop pulses ($\pm 10V/100$ pulses) (Note)																																														
11	Load side droop pulses ($\pm 10V/1000$ pulses) (Note)																																														
12	Load side droop pulses ($\pm 10V/10000$ pulses) (Note)																																														
13	Load side droop pulses ($\pm 10V/100000$ pulses) (Note)																																														
14	Load side droop pulses ($\pm 10V/1000000$ pulses) (Note)																																														
15	Motor side · load side position deviation ($\pm 10V/100000$ pulses)																																														
16	Motor side · load side speed deviation ($\pm 8V/\text{Max.speed}$)																																														
PC10	MOD2	<p>Analog monitor 2 output Used to selection the signal provided to the analog monitor 2 (MO2) output. (Refer to section 5.3.3)</p> <div style="border: 1px solid black; display: inline-block; padding: 2px;"> <table border="1" style="border-collapse: collapse;"> <tr> <td style="width: 20px; text-align: center;">0</td> <td style="width: 20px; text-align: center;">0</td> <td style="width: 20px;"></td> <td style="width: 20px;"></td> </tr> </table> </div> <p style="margin-left: 40px;">└─ Analog monitor 2 (MO2) output selection The settings are the same as those of the analog monitor 1 output. For details, refer to the parameter No.PC09.</p>	0	0			0001h		Refer to Name and function column.																																						
0	0																																														

5. PARAMETERS

No.	Symbol	Name and function	Initial value	Unit	Setting range				
PC26	** COP8	<p>Function selection C-8 Used to select the communication system of the serial interface encoder cable to be connected to the CN2L connector.</p> <table border="1" style="margin-left: 20px;"> <tr> <td style="width: 20px; height: 20px;"></td> <td style="width: 20px; height: 20px; text-align: center;">1</td> <td style="width: 20px; height: 20px; text-align: center;">0</td> <td style="width: 20px; height: 20px; text-align: center;">0</td> </tr> </table> <p style="margin-left: 20px;">└── Load side encoder cable communication system selection 0: 2-wire type 1: 4-wire type If the setting is incorrect, the load side encoder error1 (70) or load side encoder error2 (71) occurs.</p>		1	0	0	0100h		Refer to Name and function column.
	1	0	0						
PC27	** COP9	<p>Function Selection C-9 Polarity of the encoder connected to the CN2L connector and the Z-phase connection judgement of the ABZ-phase input interface encoder are selected.</p> <table border="1" style="margin-left: 20px;"> <tr> <td style="width: 20px; height: 20px; text-align: center;">0</td> <td style="width: 20px; height: 20px;"></td> <td style="width: 20px; height: 20px; text-align: center;">0</td> <td style="width: 20px; height: 20px;"></td> </tr> </table> <p style="margin-left: 20px;">└── Selection of encoder pulse count polarity 0: Encoder pulse increasing direction on the servo motor CCW 1: Encoder pulse decreasing direction on the servo motor CCW</p> <p style="margin-left: 20px;">└── Selection of ABZ-phase input interface encoder Z-phase connection judgement function Alarm judgement function without the Z-phase connection is selected when the ABZ-phase input interface encoder is connected. 0: Alarm valid If not connected, the load side encoder error 2 (71) occurs. 1: Alarm invalid Even if not connected, the load side encoder error 2 (71) does not occur.</p>	0		0		0000h		Refer to Name and function column.
0		0							

5. PARAMETERS

5.3.3 Analog monitor

The servo status can be output to two channels in terms of voltage.

(1) Setting

Change the following digits of parameter No.PC09,PC10.

Parameter No.PC09

0	0		
---	---	--	--

Analog monitor (MO1) output selection
(Signal output to across MO1-LG)

Parameter No.PC10

0	0		
---	---	--	--

Analog monitor (MO2) output selection
(Signal output to across MO2-LG)

Parameters No.PC11 and PC12 can be used to set the offset voltages to the analog output voltages. The setting range is between -999 and 999 mV.

Parameter No.	Description	Setting range [mV]
PC11	Used to set the offset voltage for the analog monitor 1 (MO1).	-999 to 999
PC12	Used to set the offset voltage for the analog monitor 2 (MO2).	

(2) Set content

The servo amplifier is factory-set to output the servo motor speed to analog monitor 1 (MO1) and the torque to analog monitor (MO2). The setting can be changed as listed below by changing the parameter No.PC14 and PC12 value.

Refer to (3) for the measurement point.

Setting	Output item	Description	Setting	Output item	Description
00	Servo motor speed		01	Torque (Note 2)	
02	Servo motor speed		03	Torque (Note 2)	
04	Current command		05	Speed command	

5. PARAMETERS

Setting	Output item	Description	Setting	Output item	Description
06	Motor side droop pulses (Note 1) (±10V/100 pulses)		07	Motor side droop pulses (Note 1) (±10V/1000 pulses)	
08	Motor side droop pulses (Note 1) (±10V/10000 pulses)		09	Motor side droop pulses (Note 1) (±10V/100000 pulses)	
0D	Bus voltage		10	Load side droop pulses (Note 1) (±10V/100 pulses)	
11	Machine side droop pulses (Note 1) (±10V/1000 pulses)		12	Load side droop pulses (Note 1) (±10V/10000 pulses)	
13	Load side droop pulses (Note 1) (±10V/100000 pulses)		14	Load side droop pulses (Note 1) (±10V/1M pulses)	
15	Motor side * load side position deviation (Note 1) (±10V/100000 pulses)		16	Motor side * load side speed deviation	

Note 1. Output in the load side encoder unit for the fully closed loop control and in the motor encoder unit for the semi closed loop control.

2. Outputs 8V at the maximum torque.

5. PARAMETERS

(3) Analog monitor block diagram (fully closed loop)

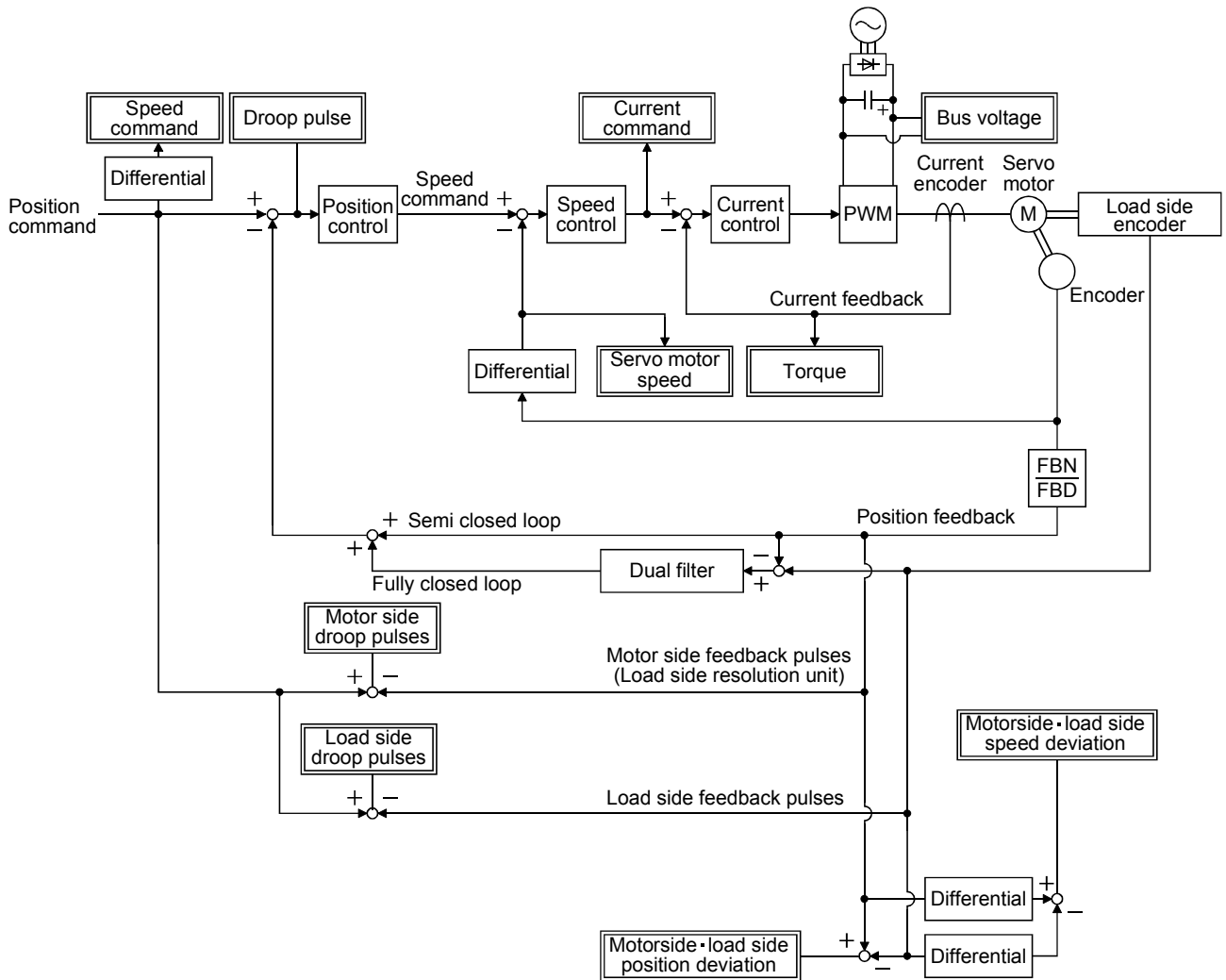

5. PARAMETERS

5.4 I/O setting parameters (No.PD□□)

POINT
<ul style="list-style-type: none"> Parameter whose symbol is preceded by * is made valid with the following conditions.
* : Set the parameter value, switch power off once after setting, and then switch it on again, or perform the controller reset.

5.4.1 Parameter list

No.	Symbol	Name	Initial value	Unit	Reference
PD01		For manufacturer setting	0000h		Chapter 5 of the MR-J3- □B Servo Amplifier Instruction Manual
PD02			0000h		
PD03			0000h		
PD04			0000h		
PD05			0000h		
PD06			0000h		
PD07	*D01	Output signal device selection 1 (CN3-pin 13)	0005h		
PD08	*D02	Output signal device selection 2 (CN3-pin 9)	0004h		
PD09	*D03	Output signal device selection 3 (CN3-pin 15)	0003h		
PD10		For manufacturer setting	0000h		
PD11			0004h		
PD12			0000h		
PD13			0000h		
PD14	*D0P3	Function selection D-3	0000h		
PD15		For manufacturer setting	0000h		
PD16			0000h		
PD17			0000h		
PD18			0000h		
PD19			0000h		
PD20			0000h		
PD21			0000h		
PD22			0000h		
PD23			0000h		
PD24			0000h		
PD25			0000h		
PD26			0000h		
PD27			0000h		
PD28			0000h		
PD29			0000h		
PD30			0000h		
PD31			0000h		
PD32			0000h		

5. PARAMETERS

5.5 Extension control parameters (No. PE□□)

POINT
<ul style="list-style-type: none"> Parameter whose symbol is preceded by * is made valid with the following conditions.
<ul style="list-style-type: none"> * : Set the parameter value, switch power off once after setting, and then switch it on again, or perform the controller reset.
<ul style="list-style-type: none"> ** : Set the parameter value, switch power off once, and then switch it on again.

5.5.1 Parameter list

No.	Symbol	Name	Initial value	Unit
PE01	**FCT1	Fully closed loop selection 1	0000h	
PE02		For manufacturer setting	0102h	
PE03	*FCT2	Fully closed loop selection 2	0003h	
PE04	**FBN	Fully closed loop feedback pulse electronic gear numerator 1	1	
PE05	**FBD	Fully closed loop feedback pulse electronic gear denominator 1	1	
PE06	BC1	Fully closed loop control speed deviation error detection level	400	r/min
PE07	BC2	Fully closed loop control position deviation error detection level	100	kpulse
PE08	DUF	Fully closed loop dual feedback filter	10	rad/s
PE09		For manufacturer setting	0000h	
PE10	FCT3	Fully closed loop selection 3	0000h	
PE11		For manufacturer setting	0	
PE12			40	
PE13			FFFEh	
PE14			0111h	
PE15			20	
PE16			0000h	
PE17			0000h	
PE18			0000h	
PE19			0000h	
PE20			0000h	
PE21			0000h	
PE22			0000h	
PE23			0000h	
PE24			0000h	
PE25			0000h	
PE26			0000h	
PE27			0000h	
PE28			0000h	
PE29			0000h	
PE30		0000h		
PE31		0000h		
PE32		0000h		
PE33		0000h		
PE34	**FBN2	Fully closed loop feedback pulse electronic gear numerator 2	1	
PE35	**FBD2	Fully closed loop feedback pulse electronic gear denominator 2	1	
PE36		For manufacturer setting	0.0	
PE37			0.00	
PE38			0.00	
PE39			0000h	
PE40			0000h	

5. PARAMETERS

5.5.2 List of details

No.	Symbol	Name and function	Initial value	Unit	Setting range										
PE01	**FCT1	<p>Fully closed loop Selection 1 Select the semi closed loop control/fully closed loop control.</p> <p>Parameter No. PE01</p> <table border="1" style="margin-left: 20px;"> <tr> <td style="width: 20px; text-align: center;">0</td> <td style="width: 20px; text-align: center;">0</td> <td style="width: 20px; text-align: center;">0</td> <td style="width: 20px; text-align: center;">□</td> </tr> </table> <p style="margin-left: 40px;">Fully closed loop control selection 0: Always fully closed loop control 1: Selection using the control command of controller</p> <table border="1" style="margin-left: 40px; width: 150px;"> <thead> <tr> <th style="width: 50%;">Selection using the control command of controller</th> <th style="width: 50%;">Control method</th> </tr> </thead> <tbody> <tr> <td style="text-align: center;">OFF</td> <td style="text-align: center;">Semi closed loop control</td> </tr> <tr> <td style="text-align: center;">ON</td> <td style="text-align: center;">Fully closed loop control</td> </tr> </tbody> </table> <p style="margin-left: 40px;">When parameter No. PA01 control configuration is set to "□□1□" (fully closed loop system), this setting is enabled.</p>	0	0	0	□	Selection using the control command of controller	Control method	OFF	Semi closed loop control	ON	Fully closed loop control	0000h		Refer to Name and function column.
0	0	0	□												
Selection using the control command of controller	Control method														
OFF	Semi closed loop control														
ON	Fully closed loop control														
PE02		<p>For manufacturer setting Do not change this value by any means.</p>	0102h												
PE03	**FCT2	<p>Fully closed loop Selection 2 Set the fully closed loop control error detection function, position deviation error detection system and fully closed loop control error reset.</p> <table border="1" style="margin-left: 20px;"> <tr> <td style="width: 20px; text-align: center;">□</td> <td style="width: 20px; text-align: center;">0</td> <td style="width: 20px; text-align: center;">□</td> <td style="width: 20px; text-align: center;">□</td> </tr> </table> <p style="margin-left: 40px;">Fully closed loop control error detection function selection 0: Invalid 1: Speed deviation error detection 2: Position deviation error detection 3: Speed deviation error/position deviation error detection</p> <p style="margin-left: 40px;">Position deviation error detection system selection Selects a detection condition regarding the fully closed loop control error and the position deviation error of the detection function. 0: Standard position deviation detection system (constant detection) 1: Position deviation detection system at stop (detected with command set to 0)</p> <p style="margin-left: 40px;">Fully closed loop control error reset selection Selects an alarm reset condition from the controller when the fully closed loop control error detection (42) occurs. 0: Reset disabled (reset by powering OFF enabled) 1: Reset enabled</p>	□	0	□	□	0003h		Refer to Name and function column.						
□	0	□	□												
PE04	**FBN	<p>Fully closed loop control feedback pulse electronic gear 1 numerator Used to set the numerator of the electronic gear to the motor encoder pulse. Set the electronic gear so that the number of pulses for one servo motor revolution is converted to the resolution of the load side encoder.</p>	1		1 to 65535										
PE05	**FBD	<p>Fully closed loop control feedback pulse electronic gear 1 denominator Used to set the denominator of the electronic gear to the motor encoder pulse. Set the electronic gear so that the number of pulses for one servo motor revolution is converted to the resolution of the load side encoder.</p>	1		1 to 65535										

5. PARAMETERS

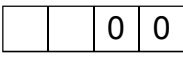
No.	Symbol	Name and function	Initial value	Unit	Setting range
PE06	BC1	Fully closed loop control speed deviation error detection level Used to set the speed deviation error detection level of the fully closed loop control error detection. Valid/invalid of this function can be selected in parameter No.PE03(FCT2). Note. If the software version is A0, an alarm error (37) occurs when a value exceeding the permissible speed is set. If the software version is B0, the alarm error (37) does not occur when a value exceeding the permissible speed is set, and the value is set within the permissible speed.	400	r/min	1 to 50000 (Note)
PE07	BC2	Fully closed loop control position deviation error detection level Used to set the position deviation error detection level of the fully closed loop control error detection. Valid/invalid of this function can be selected in parameter No.PE03(FCT2).	100	kpulse	1 to 20000
PE08	DUF	Fully closed loop dual feedback filter Used to set the band of the dual feedback filter. For the dual feedback filter, refer to section 1.5.2.	10	rad/s	0 to 4500
PE09		For manufacturer setting Do not change this value by any means.	0000h		
PE10	FCT3	Fully closed loop selection 3 Used to set the monitor information of the controller.  <p> Droop pulse monitor setting for controller display Sets the encoder to be used for the droop pulse monitor for controller display. 0: Motor encoder 1: Load side encoder 2: Difference between the motor side and load side For the semi closed loop control, the motor encoder is used regardless of the settings. </p> <p> Cumulative feedback pulses monitor setting for controller display Sets the encoder to be used for the cumulative feedback pulses monitor for controller display. 0: Motor encoder 1: Load side encoder For the semi closed loop control, the motor encoder is used regardless of the settings. </p>	0000h		Refer to Name and function column.
PE11		For manufacturer setting	0		
PE12		Do not change this value by any means.	40		
PE13			FFFEh		
PE14			0111h		
PE15			20		
PE16			0000h		
PE17			0000h		
PE18			0000h		
PE19			0000h		
PE20			0000h		
PE21			0000h		
PE22			0000h		
PE23			0000h		
PE24			0000h		
PE25			0000h		
PE26			0000h		
PE27			0000h		

5. PARAMETERS

No.	Symbol	Name and Function	Initial Value	Unit	Setting Range
PE28		For manufacturer setting	0000h		
PE29		Do not change this value by any means.	0000h		
PE30			0000h		
PE31			0000h		
PE32			0000h		
PE33			0000h		
PE34	**FBN2	Fully closed loop control feedback pulse electronic gear 2 numerator Used to set the numerator of the electronic gear to the motor encoder pulse. Set the electronic gear so that the number of pulses for one servo motor revolution is converted to the resolution of the load side encoder. When the set value is "0", it is identified as "1" inside.	1		0 to 32767
PE35	**FBD2	Fully closed loop control feedback pulse electronic gear 2 denominator Used to set the denominator of the electronic gear to the motor encoder pulse. Set the electronic gear so that the number of pulses for one servo motor revolution is converted to the resolution of the load side encoder. When the set value is "0", it is identified as "1" inside.	1		0 to 32767
PE36		For manufacturer setting	0.0		
PE37		Do not change this value by any means.	0.00		
PE38			0.00		
PE39			0000h		
PE40			0000h		

6. TROUBLESHOOTING

6. TROUBLESHOOTING

POINT
<ul style="list-style-type: none"> Alarms and warnings are basically the same as those of MR-J3-□B servo amplifier. This chapter describes the contents different from those of MR-J3-□B servo amplifier. As soon as an alarm occurs, make the servo off status and interrupt the main circuit power. Remedies for warnings are the same as those of MR-J3-□B servo amplifier. Refer to chapter 8 of the MR-J3-□B Servo Amplifier Instruction Manual.

If an alarm has occurred, refer to this chapter and remove its cause.

6.1 Alarms and warning list

When a fault occurs during operation, the corresponding alarm or warning is displayed. Refer to section 6.2 of this manual and section 8.2 of the MR-J3-□B Servo Amplifier Instruction Manual at an alarm occurrence and section 6.3 of this manual and section 8.3 of the MR-J3-□B Servo Amplifier Instruction Manual at a warning occurrence, and then take the appropriate action. When an alarm occurs, the ALM turns OFF.

After its cause has been removed, the alarm can be deactivated in any of the methods marked ○ in the alarm deactivation column. The alarm is automatically canceled after removing the cause of occurrence.

	Display	Name	Alarm deactivation		
			Power OFF→ON	Error reset	CPU reset
Alarms	10	Undervoltage	○	○	○
	12	Memory error 1(RAM)	○	△	△
	13	Clock error	○	△	△
	15	Memory error 2(EEP-ROM)	○	△	△
	16	Encoder error 1 (At power on)	○	△	△
	17	Board error	○	△	△
	19	Memory error 3(Flash-ROM)	○	△	△
	1A	Motor combination error	○	△	△
	20	Encoder error 2 (During runtime)	○	△	△
	21	Encoder error 3 (During runtime)	○	△	△
	24	Main circuit error	○	○	○
	28	Linear encoder error 2	○	△	△
	2A	Linear encoder error 1	○	△	△
	30	Regenerative error	(Note 1) ○	(Note 1) ○	(Note 1) ○
	31	Overspeed	○	○	○
	32	Overcurrent	○	△	△
	33	Overvoltage	○	○	○
	34	Receive error 1	○	(Note 2) ○	○
	35	Command frequency alarm	○	○	○
	36	Receive error 2	○	○	○
	37	Parameter error	○	△	△
	42	Fully closed loop control error detection	○	(Note 3) ○	(Note 3) ○
	45	Main circuit device overheat	(Note 1) ○	(Note 1) ○	(Note 1) ○
	46	Servo motor overheat	(Note 1) ○	(Note 1) ○	(Note 1) ○
	47	Cooling fan alarm	○	△	△
	50	Overload 1	(Note 1) ○	(Note 1) ○	(Note 1) ○
	51	Overload 2	(Note 1) ○	(Note 1) ○	(Note 1) ○
	52	Error excessive	○	○	○
70	Load side encoder error 1	○	△	△	
71	Load side encoder error 2	○	△	△	
8A	USB communication time-out error	○	○	○	
8E	USB communication error	○	○	○	
888	Watchdog	○	△	△	

	Display	Name
Warnings	96	Home position setting error
	E0	Excessive regeneration warning
	E1	Overload warning 1
	E4	Parameter warning
	E6	Servo forced stop warning
	E7	Controller emergency stop warning
	E8	Cooling fan speed reduction warning
	E9	Main circuit off warning
	EC	Overload warning 2
	ED	Output watt excess warning

Note 1. Deactivate the alarm about 30 minutes of cooling time after removing the cause of occurrence.

2. In some controller communication status, the alarm factor may not be removed.

3. Set parameter No.PE03 to "1□□□" to deactivate.

6. TROUBLESHOOTING

6.2 Remedies for alarms



CAUTION

- When any alarm has occurred, eliminate its cause, ensure safety, then reset the alarm, and restart operation. Otherwise, injury may occur.
- As soon as an alarm occurs, mark Servo-off and power off the main circuit and control circuit.

POINT

- When any of the following alarms has occurred, do not deactivate the alarm and resume operation repeatedly. To do so will cause the servo amplifier/servo motor to fail. Remove the cause of occurrence, and leave a cooling time of more than 30 minutes before resuming operation. To protect the main circuit elements, any of these servo alarms cannot be deactivated from the servo system controller until the specified time elapses after its occurrence. Judging the load changing condition until the alarm occurs, the servo amplifier calculates this specified time automatically.
 - Regenerative error (30)
 - Servo motor overhear (46)
 - Overload 2 (51)
 - Main circuit device overhear (45)
 - Overload 1 (50)
- The alarm can be deactivated by switching power off, then on or by the error reset command ▪ CPU reset from the servo system controller. For details, refer to section 6.1.

When an alarm occurs, the trouble (ALM) switches off and the dynamic brake is operated to stop the servo motor. At this time, the display indicates the alarm No.

The servo motor comes to a stop. Remove the cause of the alarm in accordance with this section. MR Configurator may be used to refer to the cause.

Display	Name	Definition	Cause	Action
10	Undervoltage	Refer to chapter 8 of the MR-J3-□B Servo Amplifier Instruction Manual.		
12	Memory error 1 (RAM)			
13	Clock error			
15	Memory error 2 (EEP-ROM)			
16	Encoder error 1 (At power on)			
17	Board error 2			
19	Memory error 3 (Flash ROM)			
1A	Motor combination error			
20	Encoder error 2 (During runtime)			
21	Encoder error 3 (During runtime)			
24	Main circuit error			

6. TROUBLESHOOTING

Display	Name	Definition	Cause	Action
28	Linear encoder error 2	Working environment of linear encoder is not normal.	1. The temperature of linear encoder is high.	Check the temperature of linear encoder and contact with the linear encoder manufacturer.
			2. The signal level of linear encoder has dropped.	Check the installation of the linear encoder.
2A	Linear encoder error 1	An alarm is output from the linear encoder.	1. The speed of linear encoder has exceeded the range of use.	Change the speed of linear encoder within the range of use.
			2. Noise entered.	Take the noise reduction measures.
			3. Alarm of the linear encoder	Contact with the linear encoder manufacturer.
			4. Defective installation positions of the scale and head	Adjust the positions of the scale and head.
30	Regenerative error	Refer to chapter 8 of the MR-J3-□B Servo Amplifier Instruction Manual.		
31	Overspeed			
32	Overcurrent			
33	Overload			
34	Receive error 1			
35	Command frequency error			
36	Receive error 2			
37	Parameter error	Parameter setting is wrong.	1. Servo amplifier fault caused the parameter setting to be rewritten.	Change the servo amplifier.
			2. There is a parameter whose value was set to outside the setting range by the controller.	Change the parameter value to within the setting range.
			3. The number of write times to EEPROM exceeded 100,000 due to parameter write, etc.	Change the servo amplifier.
42	Fully closed loop control error detection	A fully closed loop control error has occurred.	1. The resolution of the load side encoder differs from the setting value.	Review the settings of parameter No. PE04, PE05 (fully closed loop control feedback pulse electronic gear). Check the installation of the load side encoder.
			2. Mismatch of the load side encoder installation direction	Check the installation direction of the load side encoder. Review the encoder pulse count polarity selection in parameter No. PC27.
			3. The position deviation exceeded the detection level.	Review the operation conditions. Review the setting of parameter No. PE07 (fully closed loop control position deviation error detection level) as required.
			4. The speed deviation exceeded the detection level.	Review the operation conditions. Review the setting of parameter No. PE06 (fully closed loop control speed deviation error detection level) as required.
45	Main circuit device overheat	Refer to chapter 8 of the MR-J3-□B Servo Amplifier Instruction Manual.		
46	Servo motor overheat			
47	Cooling fan alarm			
50	Overload 1			
51	Overload 2			
52	Error excessive			

6. TROUBLESHOOTING

Display	Name	Definition	Cause	Action
70	Load side encoder error 1	An error occurs in the communication between the load side encoder and the servo amplifier.	1. CN2L connector is disconnected.	Connect correctly.
			2. Faulty of the load side encoder cable	Repair or change the cable.
			3. Wrong wiring of the load side encoder cable	Review the wiring connection.
			4. For the serial interface encoder, the load side encoder cable type (2-wire, 4-wire) selection was wrong in the parameter setting.	Correct the setting in the fourth digit of parameter No.PC26 (encoder cable communication system selection).
			5. The startup timing is slow.(For the load side encoder with the external power supply input)	Turn on the external power supply, and then turn on the control power supply of servo amplifier.
			6. The power supply voltage dropped.(For the load side encoder with the external power supply input)	Check the power supply capacity and voltage.
71	Load side encoder error 2	An error occurs in the communication between the load side encoder and the servo amplifier.	1. CN2L connector is disconnected.	Connect correctly.
			2. Faulty of the load side encoder cable	Repair or change the cable.
			3. Wrong wiring of the load side encoder cable	Review the wiring connection.
			4. The power supply voltage dropped.(For the load side encoder with the external power supply input)	Check the power supply capacity and voltage.
			5. For the serial interface encoder, the load side encoder cable type (2-wire, 4-wire) selection was wrong in the parameter setting.	Correct the setting in the fourth digit of parameter No.PC26 (encoder cable communication system selection).
			6. For ABZ-phase input interface encoder, the alarm judgement without the Z-phase disconnection was not set to "invalid" in the parameter when using the load side encoder without Z-phase.	For the load side encoder without Z-phase, set parameter No.PC27 to "□1□□".
8A	USB communication time-out error	Refer to chapter 8 of the MR-J3-□B Servo Amplifier Instruction Manual.		
8E	USB communication error			
(Note) 888	Watchdog			

Note. At power-on, "888" appears instantaneously, but it is not an error.

6. TROUBLESHOOTING

6.3 Detailed explanation of linear encoder error 1 (2A)

If the cause of Linear encoder error 1(2A) occurrence is not identified, confirm the details shown on the following table according to the alarm detailed information for the alarm history display of MR Configurator, and then contact with the linear encoder manufacturer.

Table 6.1 Detailed explanation of linear encoder error 1(2A) for each manufacturer

Detail information bit	Linear encoder error 1 (2A) details				
	Mitutoyo Corporation		Sony Manufacturing Systems Corporation	Heidenhain Corporation	Renishaw Inc.
	AT343A/AT543A	ST741/ST743			
Bit7	Optical overspeed	Servo alarm	—	Overspeed error	—
Bit6	ROM · RAM error	Signal strength alarm	—	—	Overspeed
Bit5	EEPROM error	Signal strength error	Encoder alarm	EEPROM error	—
Bit4	CPU error	Transducer error	—	CPU error	—
Bit3	Capacitive error	ABS detection error	—	ABS data error	—
Bit2	Photoelectric error	Hardware error	—	INC data error	—
Bit1	Photoelectric · capacitive data mismatch	Initialization error	Encoder warning	Scale level error INC/ABS data mismatch error —	Level error
Bit0	Initialization error	Overspeed error	—	Initialization error	—

As an example, the following describes the detailed information when Linear encoder error 1(2A) occurs in the linear encoder AT343A manufactured by Mitutoyo Corporation.

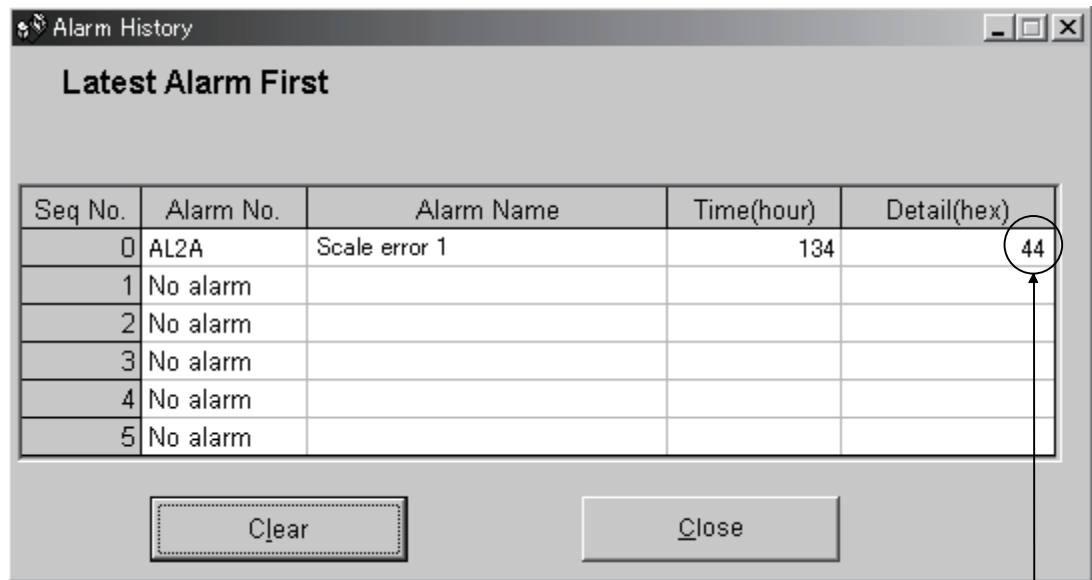

Alarm details : 44h

In this case, the alarm detailed information of Linear encoder error 1(2A) is "44". This numeral is indicated in hexadecimal number. Convert "44" of hexadecimal number to a binary-coded form as shown below.

	bit7	Bit6	Bit5	Bit4	Bit3	Bit2	Bit1	Bit0
44h =	0	1	0	0	0	1	0	0

The digits for bit6 and bit2 are "1". Check the details of the bit being "1" in Table 6.1. In this case, the occurrences of ROM · RAM error (bit6) and Photoelectric error (bit2) are identified.

7. OUTLINE DRAWINGS

7. OUTLINE DRAWINGS

POINT

- For the outline drawings of connectors, refer to section 9.2 of the MR-J3-□B Servo Amplifier Instruction Manual. For the connector for CN2L, refer to the outline drawings of the connector for CN2 since it is the same as that for CN2.

(1) MR-J3-10B-RJ006 • MR-J3-20B-RJ006
 MR-J3-10B1-RJ006 • MR-J3-20B1-RJ006

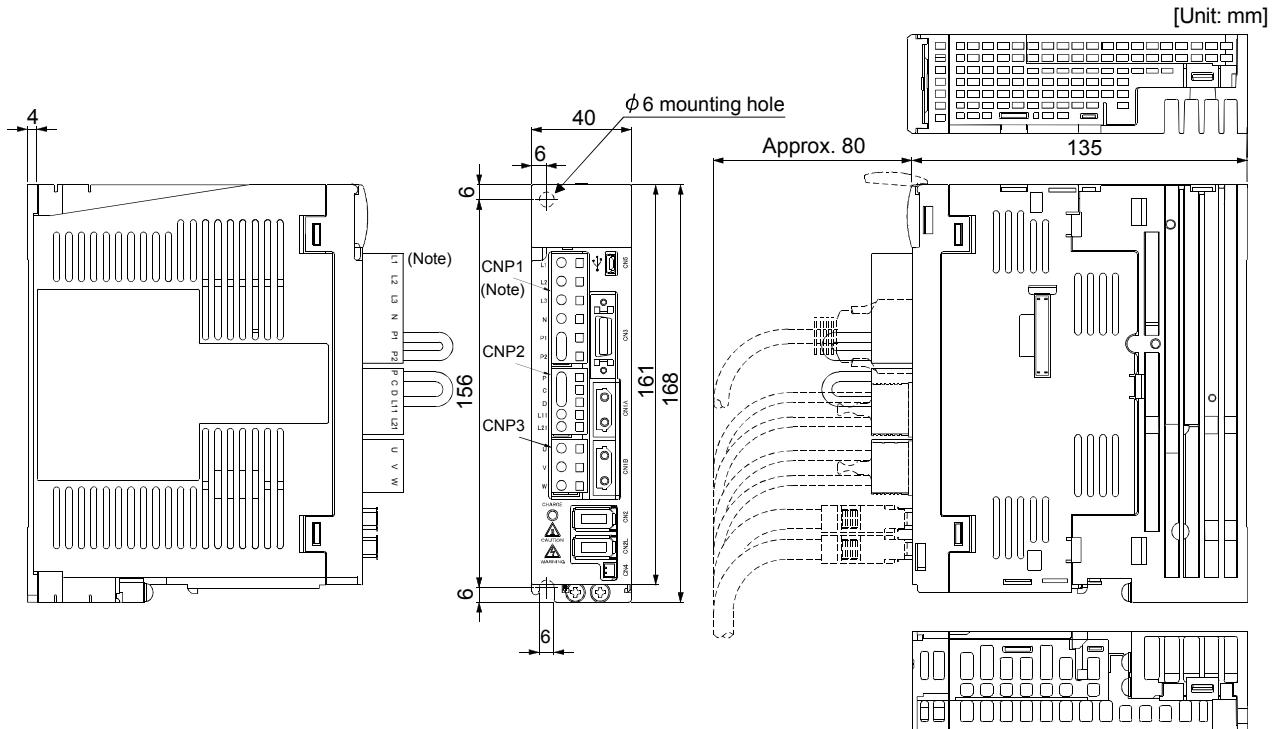

Note. This data applies to the 3-phase or 1-phase 200 to 230VAC power supply models.
 For 1-phase, 100 to 120VAC power supply, refer to the terminal signal layout.

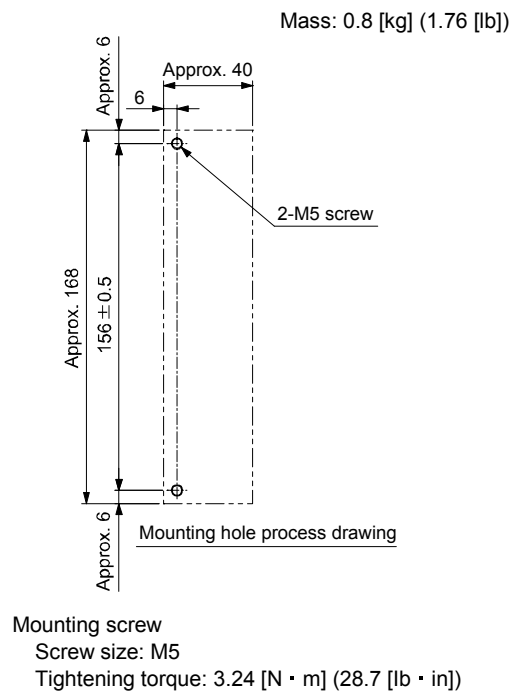
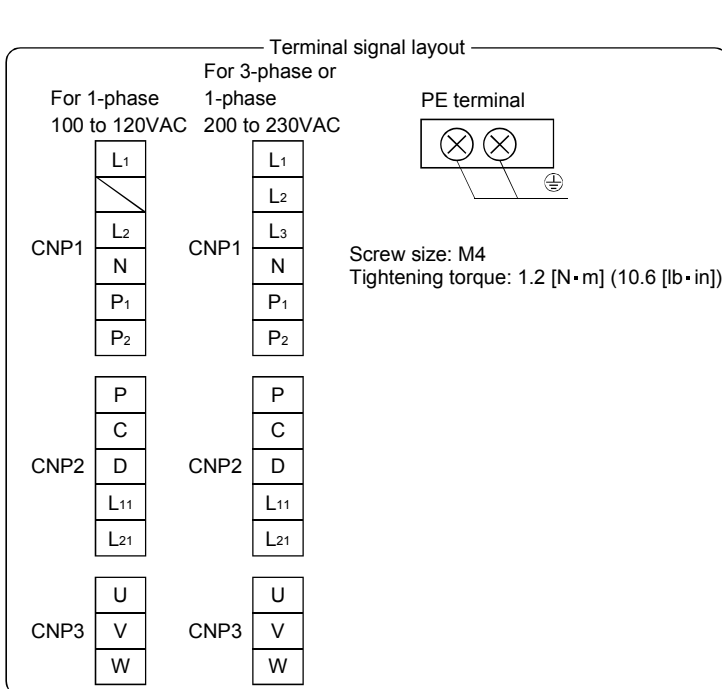

7. OUTLINE DRAWINGS

(2) MR-J3-40B-RJ006 • MR-J3-60B-RJ006
MR-J3-40B1-RJ006

[Unit: mm]

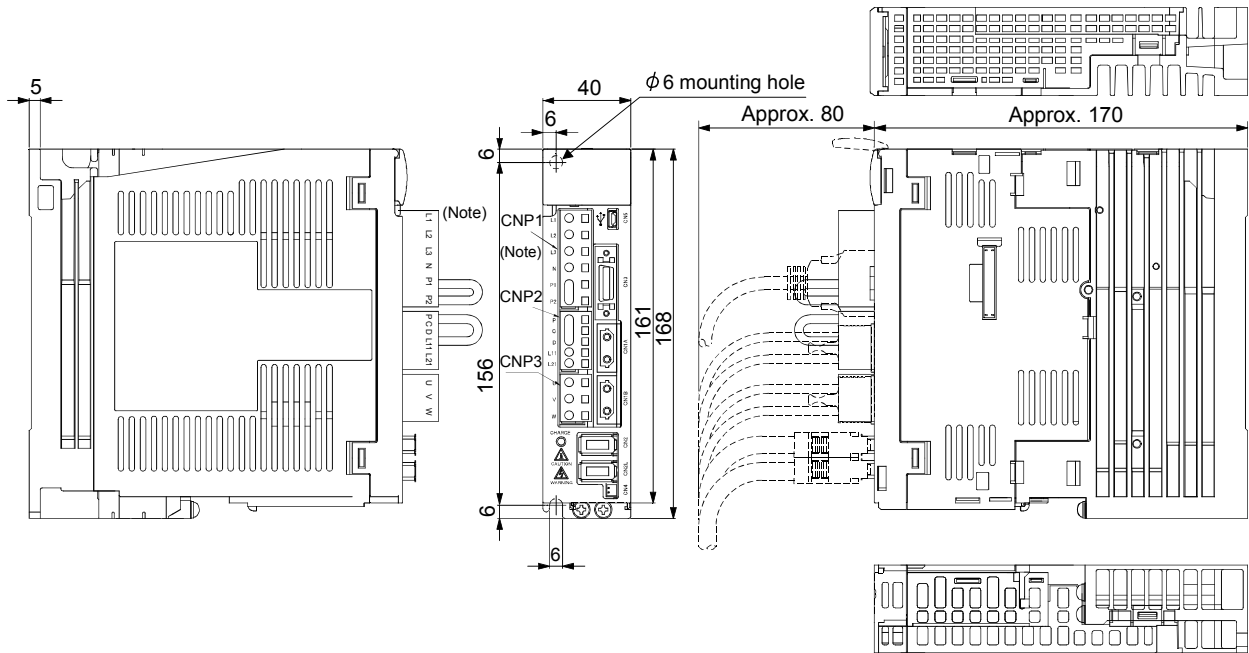

Note. This data applies to the 3-phase or 1-phase 200 to 230VAC power supply models.
For 1-phase, 100 to 120VAC power supply, refer to the terminal signal layout.

Mass: 1.0 [kg] (2.21 [lb])

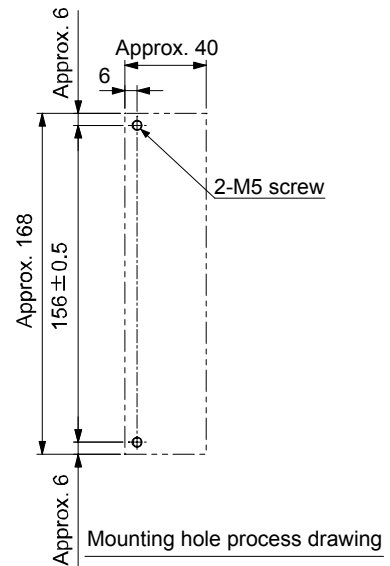
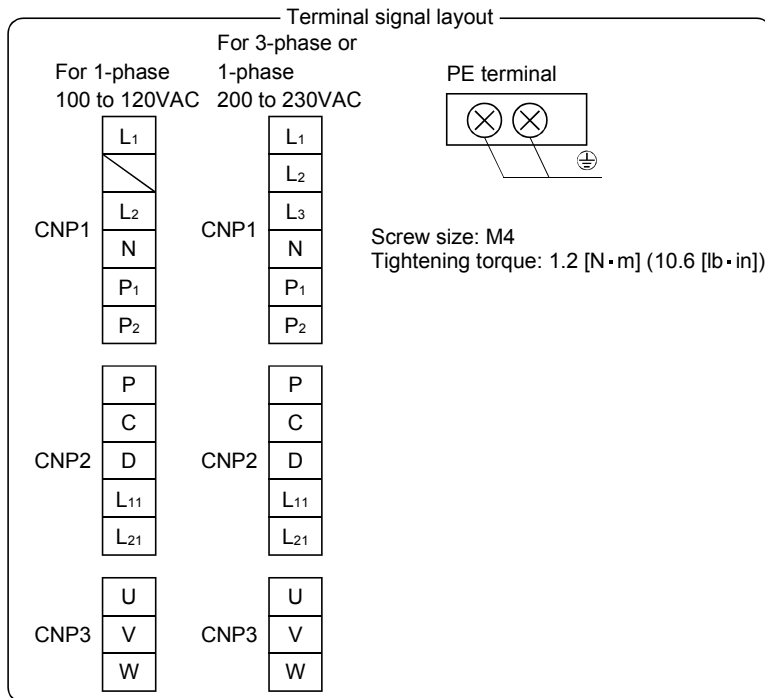

Mounting screw
Screw size: M5
Tightening torque: 3.24 [N·m] (28.7 [lb·in])

7. OUTLINE DRAWINGS

(3) MR-J3-70B-RJ006 • MR-J3-100B-RJ006

[Unit: mm]

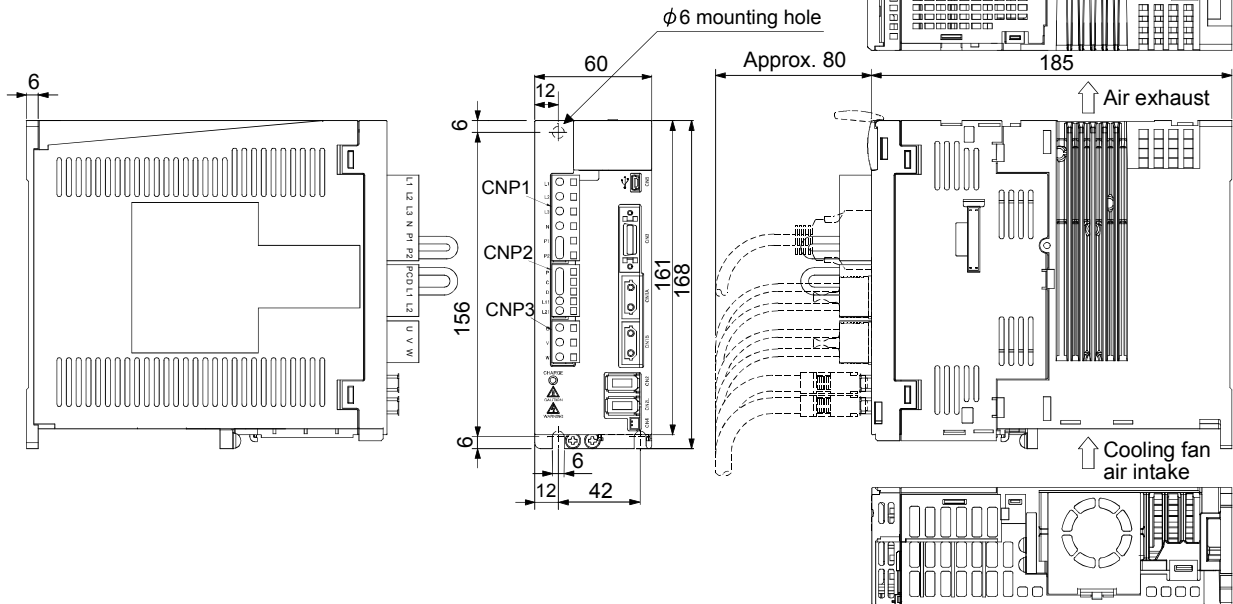

Mass: 1.4 [kg] (3.09 [lb])

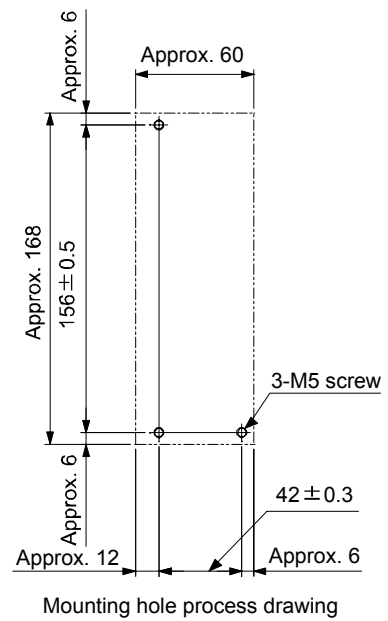
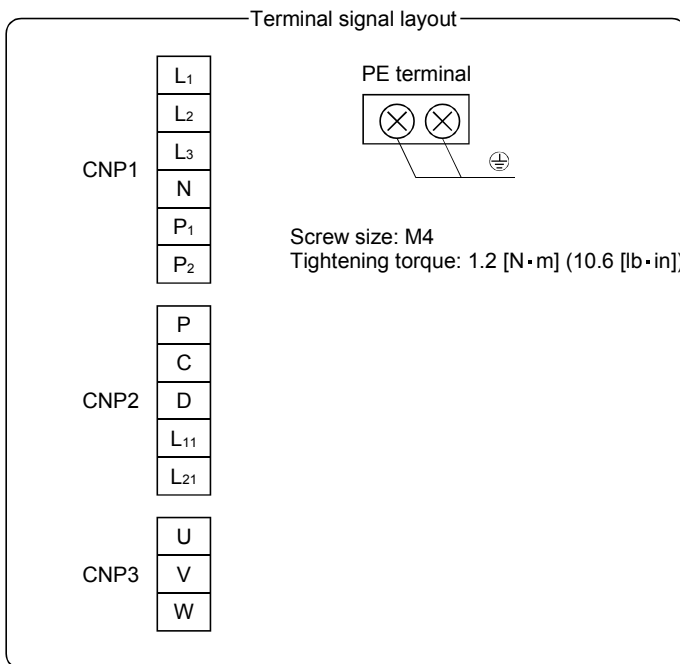

Mounting screw
Screw size: M5
Tightening torque: 3.24 [N·m] (28.7 [lb·in])

7. OUTLINE DRAWINGS

(4) MR-J3-60B4-RJ006 • MR-J3-100B4-RJ006

[Unit: mm]

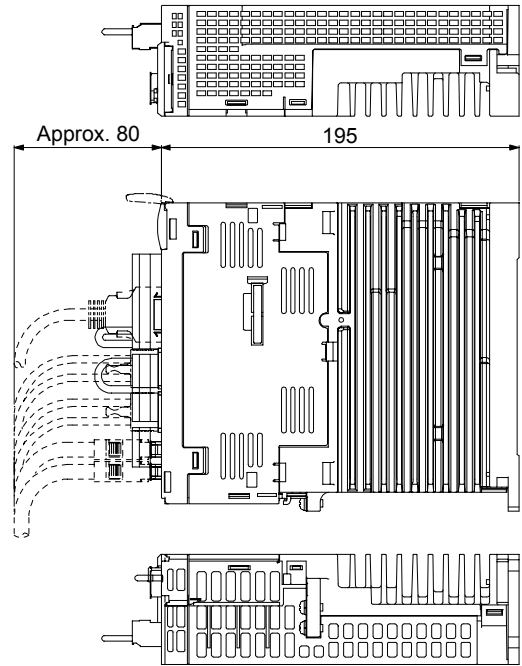
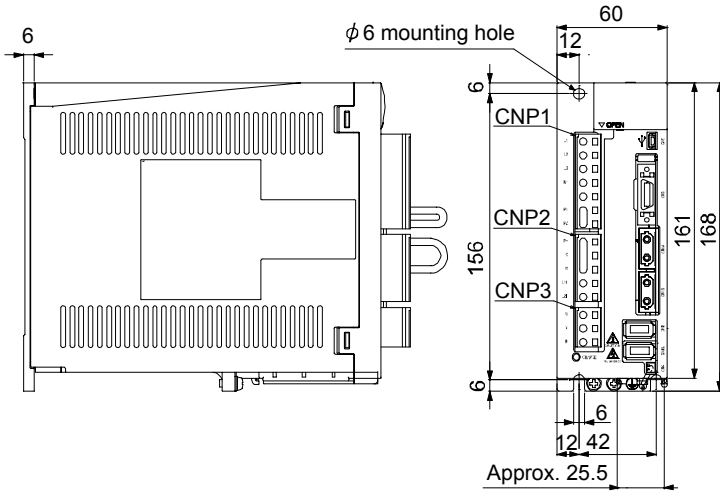

Mass: 1.7 [kg] (3.75 [lb])

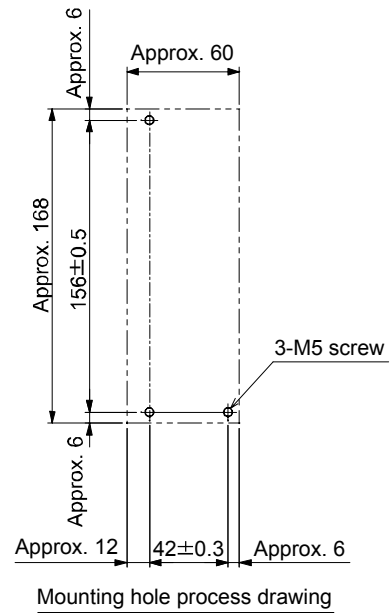
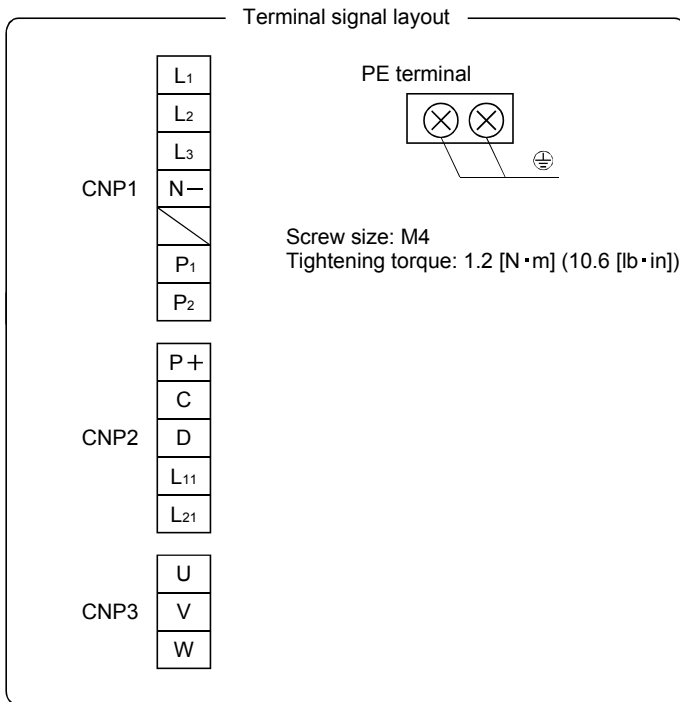

Mounting screw
Screw size: M5
Tightening torque: 3.24 [N·m]

7. OUTLINE DRAWINGS

(5) MR-J3-200B(4)-RJ006

POINT

- Connectors (CNP1, CNP2, and CNP3) and appearance of MR-J3-200B-RJ006 servo amplifier have been changed from April 2008 production. For existing servo amplifier, refer to appendix 4.

[Unit: mm]

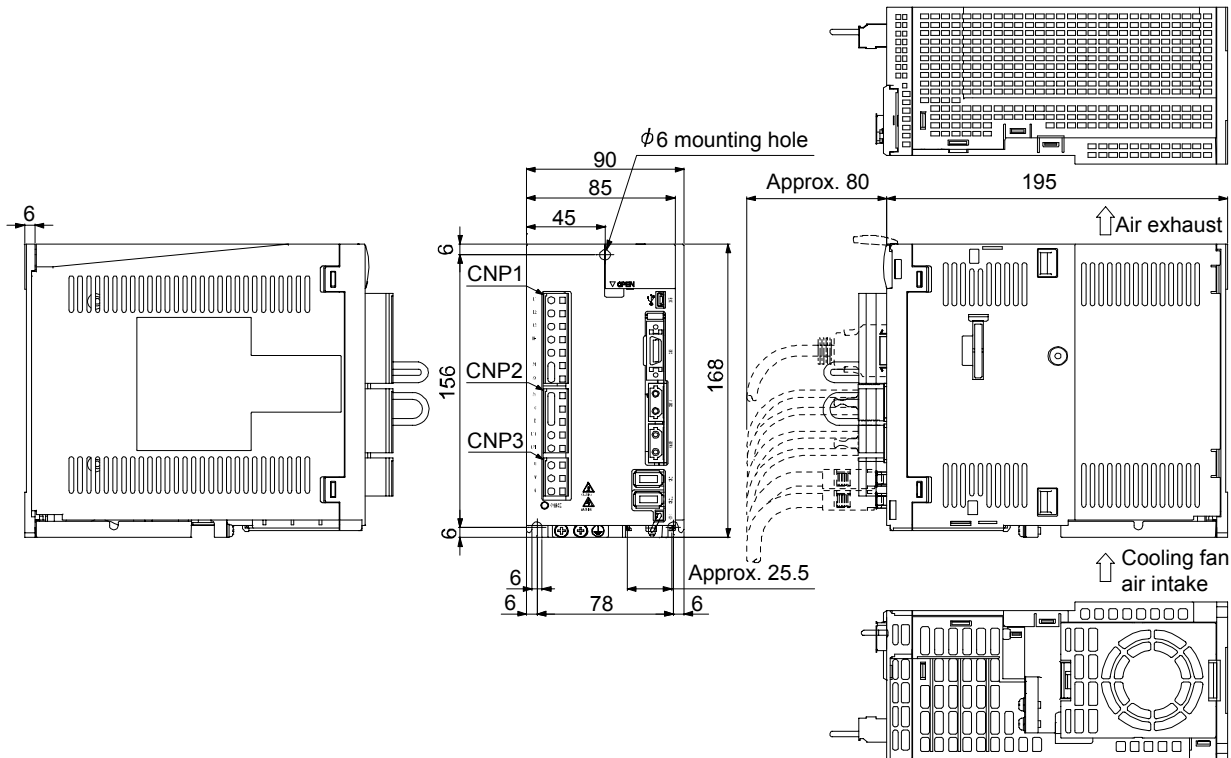

Mass: 2.1 [kg] (4.63 [lb])

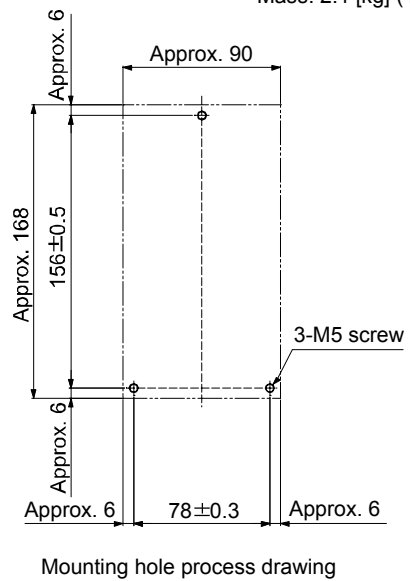
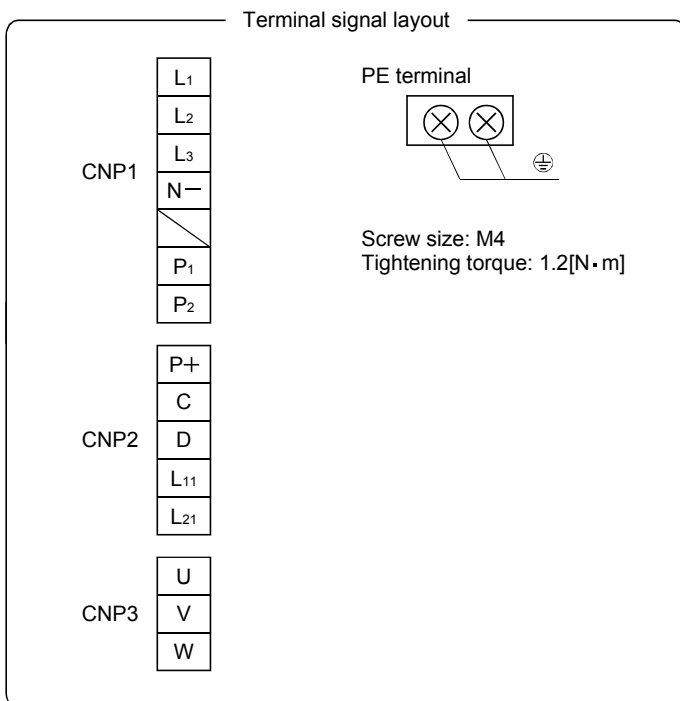

Mounting screw
Screw size: M5
Tightening torque: 3.24 [N · m]

7. OUTLINE DRAWINGS

(6) MR-J3-350B-RJ006

[Unit: mm]

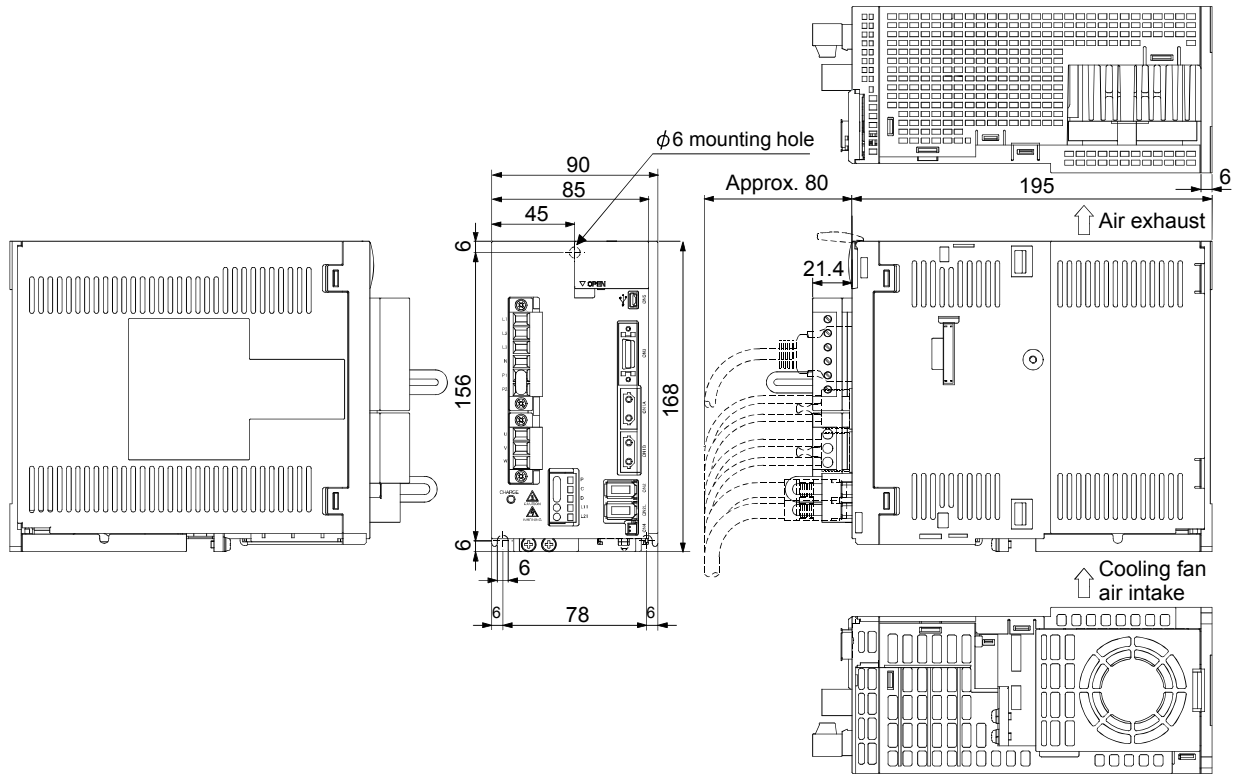

Mass: 2.3 [kg] (5.07 [lb])

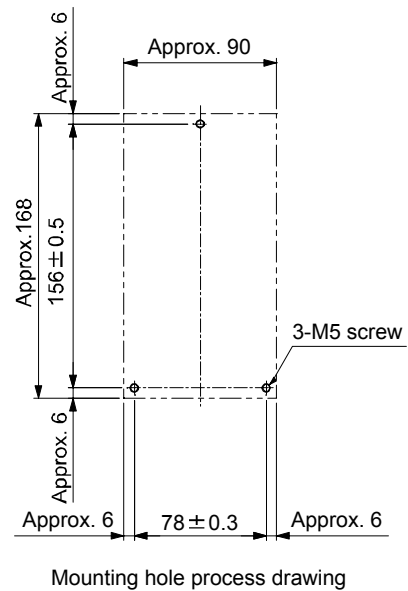
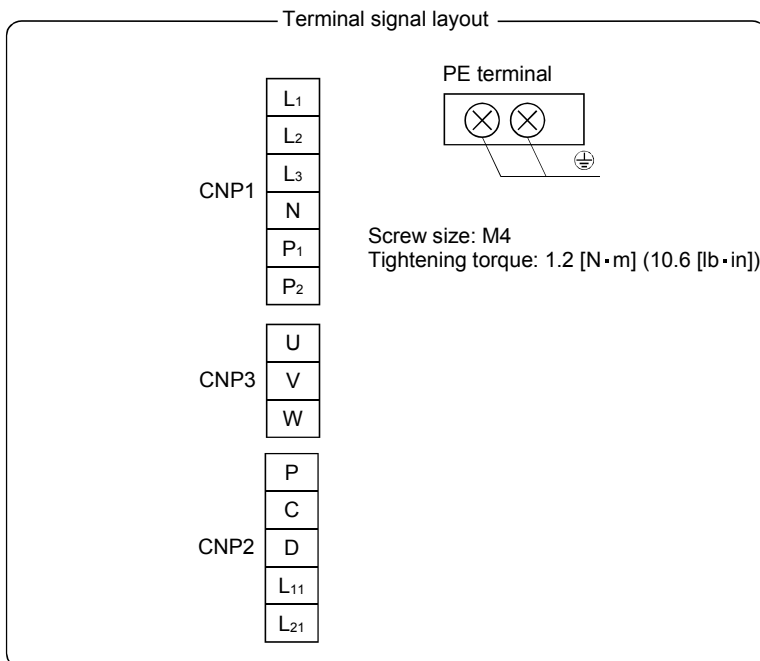

Mounting screw
Screw size: M5
Tightening torque: 3.24 [N·m] (28.7 [lb·in])

7. OUTLINE DRAWINGS

(7) MR-J3-350B4-RJ006 • MR-J3-500B(4)-RJ006

[Unit: mm]

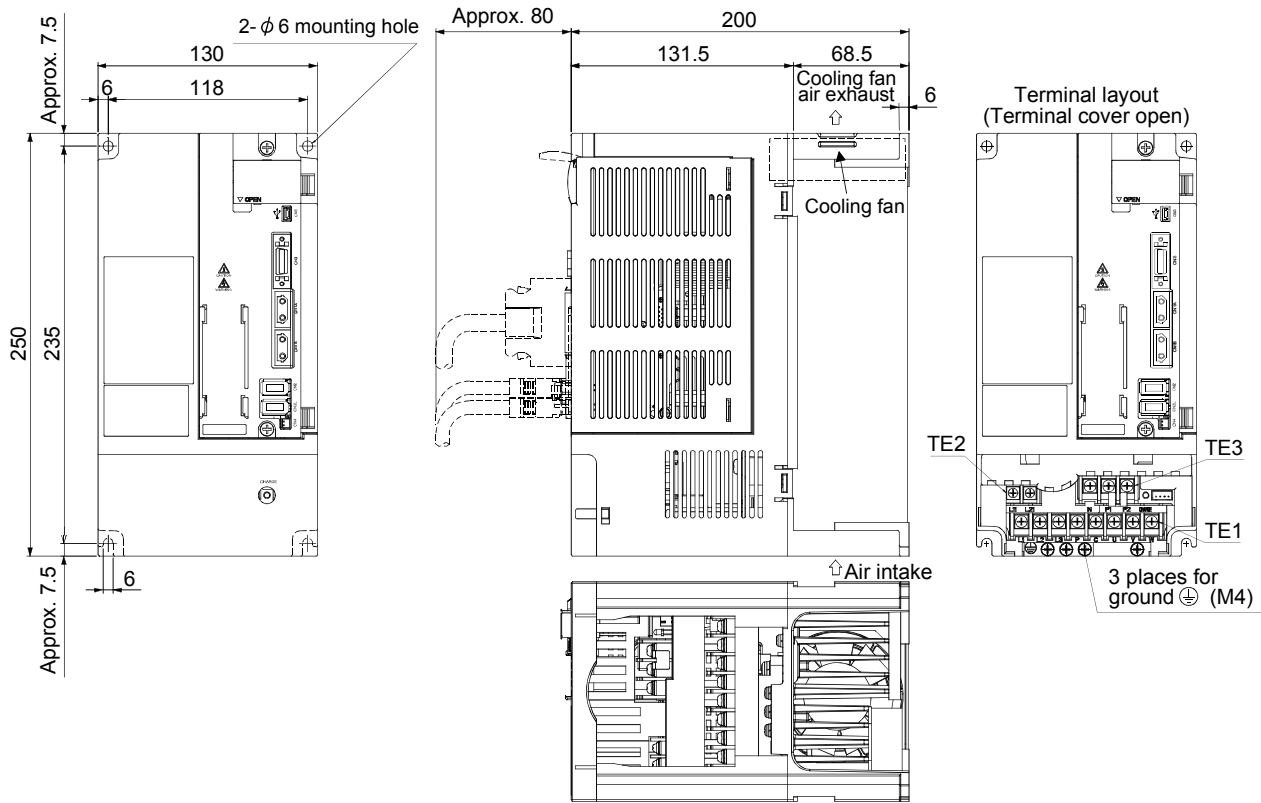

Mass: 4.6 [kg] (10.1 [lb])

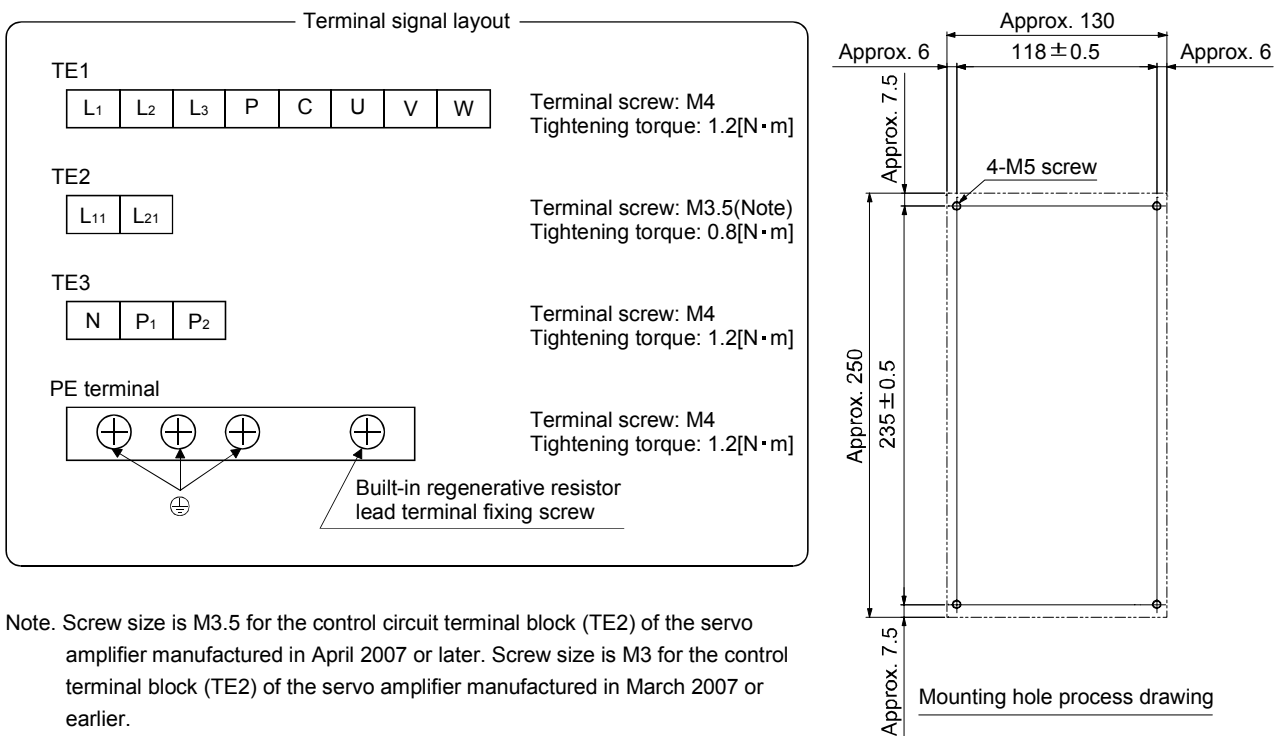

Note. Screw size is M3.5 for the control circuit terminal block (TE2) of the servo amplifier manufactured in April 2007 or later. Screw size is M3 for the control terminal block (TE2) of the servo amplifier manufactured in March 2007 or earlier.

Mounting screw
Screw size: M5
Tightening torque: 3.24 [N · m] (28.7 [lb · in])

7. OUTLINE DRAWINGS

(8) MR-J3-700B(4)-RJ006

[Unit: mm]

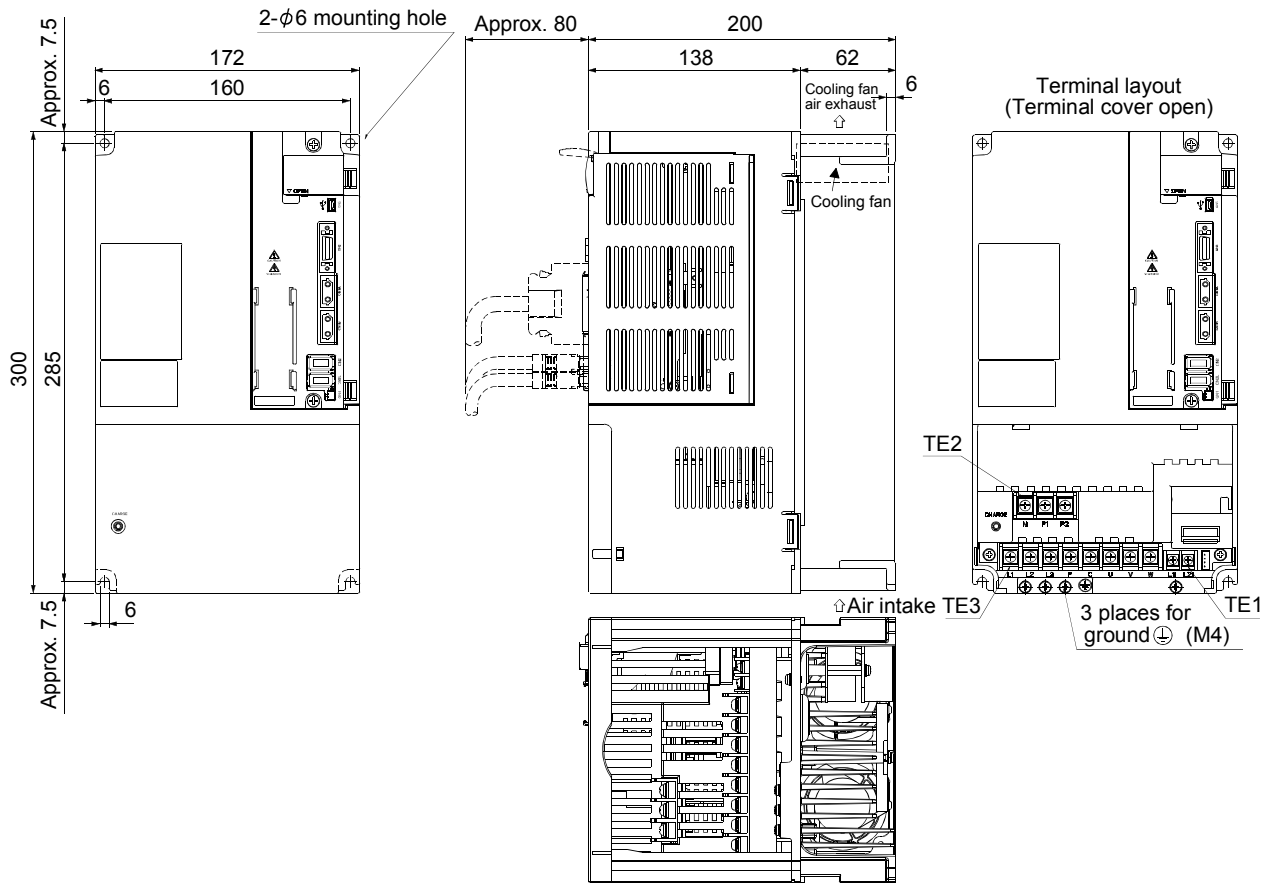

Mass: 6.2 [kg] (13.7[lb])

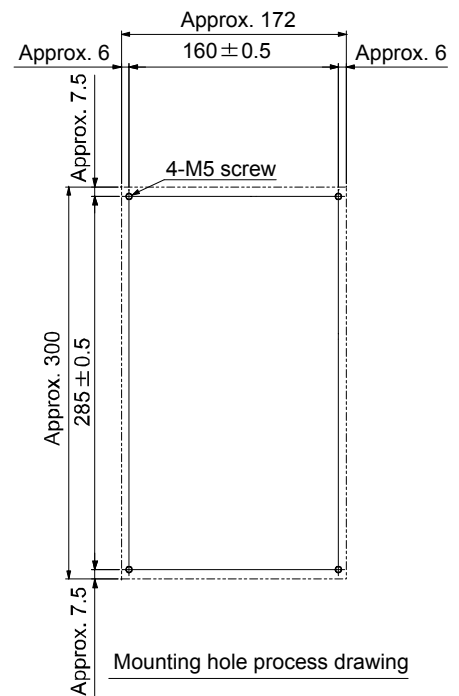
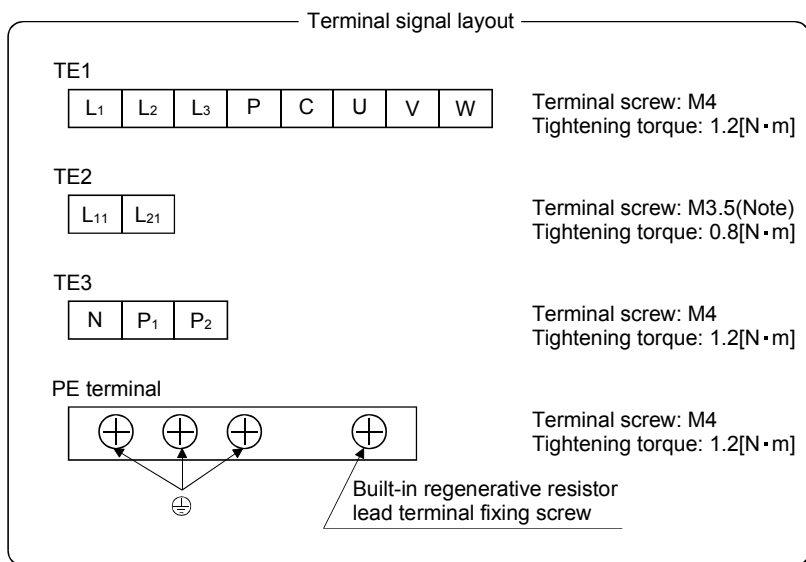

Note. Screw size is M3.5 for the control circuit terminal block (TE2) of the servo amplifier manufactured in April 2007 or later. Screw size is M3 for the control terminal block (TE2) of the servo amplifier manufactured in March 2007 or earlier.

Mounting screw
Screw size: M5
Tightening torque: 3.24 [N·m] (28.7 [lb·in])

7. OUTLINE DRAWINGS

(9) MR-J3-11KB(4)-RJ006 to 22KB(4)-RJ006

[Unit: mm]

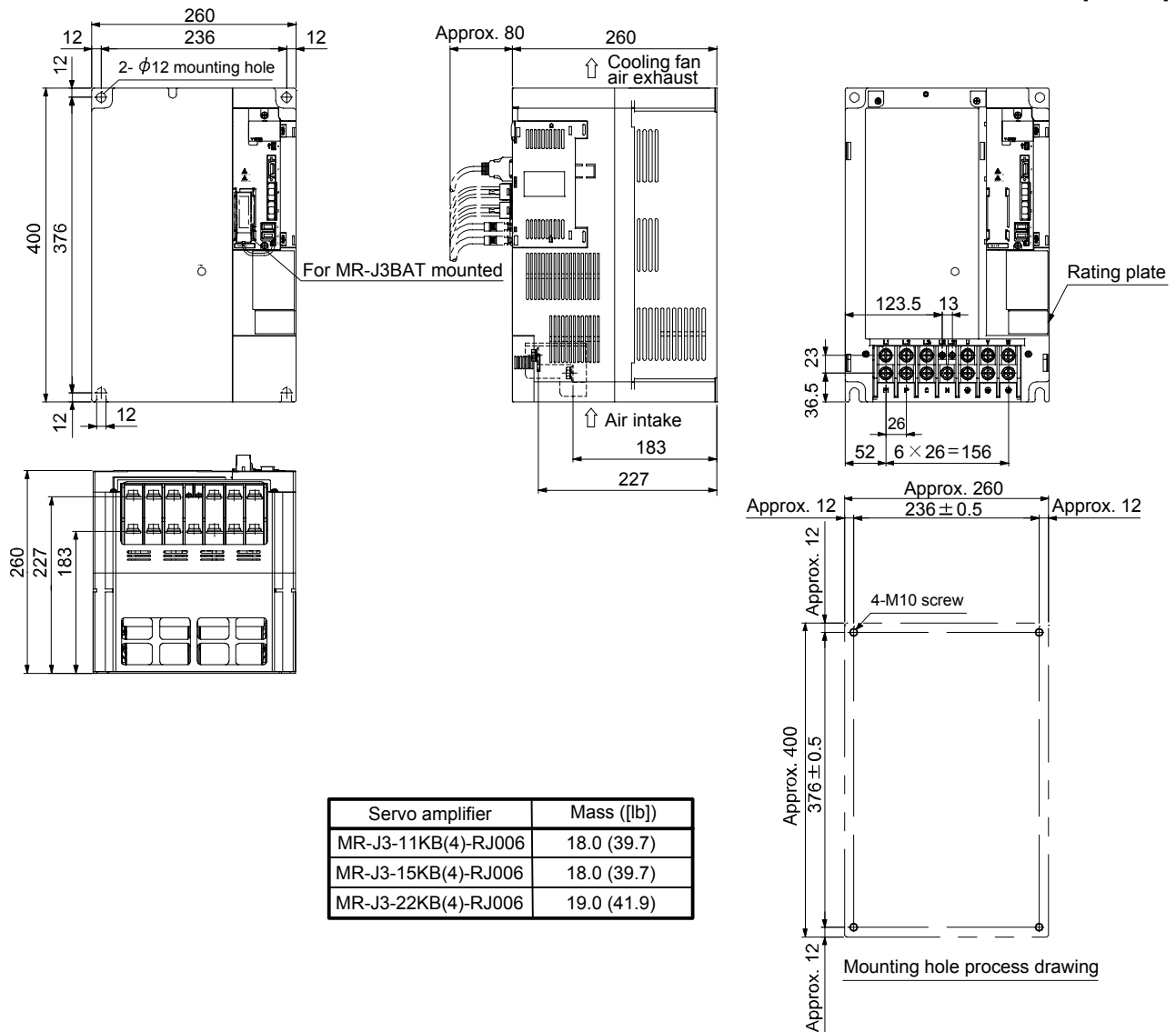

Terminal signal layout

L ₁	L ₂	L ₃	L ₁₁ , L ₂₁	U	V	W
P ₁	P	C	N	⊕	⊕	⊕

		L ₁ · L ₂ · L ₃ · U · V · W · P ₁ · P · C · N · ⊕	L ₁₁ · L ₂₁
MR-J3-11KB(4)-RJ006	Terminal screw	M6	M4
MR-J3-15KB(4)-RJ006	Tightening torque [N · m]	3.0	1.2
MR-J3-22KB(4)-RJ006	Terminal screw	M8	M4
	Tightening torque [N · m]	6.0	1.2

Mounting screw

Servo amplifier	Terminal screw	Tightening torque [N · m] ([lb · in])
MR-J3-11KB(4)-RJ006	M10	26.5 (234.5)
MR-J3-15KB(4)-RJ006		
MR-J3-22KB(4)-RJ006		

APPENDIX

App. 1 Parameter list

POINT
<ul style="list-style-type: none"> Parameter whose symbol is preceded by * is made valid with the following conditions.
* : Set the parameter value, switch power off once after setting, and then switch it on again, or perform the controller reset.
**: Set the parameter value, switch power off once, and then switch it on again.

Basic setting parameters (PA□□)		
No.	Symbol	Name
PA01	**STY	Control mode
PA02	**REG	Regenerative option
PA03	*ABS	Absolute position detection system
PA04	*AOP1	Function selection A-1
PA05 to PA07		For manufacturer setting
PA08	ATU	Auto tuning
PA09	RSP	Auto tuning response
PA10	INP	In-position range
PA11 to PA13		For manufacturer setting
PA14	*POL	Rotation direction selection
PA15	*ENR	Encoder output pulses
PA16	*ENR2	Encoder output pulses 2
PA17 to PA18		For manufacturer setting
PA19	*BLK	Parameter write inhibit

Gain/filter parameters (PB□□)		
No.	Symbol	Name
PB01	FILT	Adaptive tuning mode (Adaptive filter II)
PB02	VRFT	Vibration suppression control tuning mode (Advanced vibration suppression control)
PB03		For manufacturer setting
PB04	FFC	Feed forward gain
PB05		For manufacturer setting
PB06	GD2	For manufacturer setting Ratio of load inertia moment to servo motor inertia moment
PB07	PG1	Model loop gain
PB08	PG2	Position loop gain
PB09	VG2	Speed loop gain
PB10	VIC	Speed integral compensation
PB11	VDC	Speed differential compensation
PB12		For manufacturer setting
PB13	NH1	Machine resonance suppression filter 1
PB14	NHQ1	Notch shape selection 1
PB15	NH2	Machine resonance suppression filter 2
PB16	NHQ2	Notch shape selection 2
PB17		Automatic setting parameter
PB18	LPF	Low-pass filter setting
PB19	VRF1	Vibration suppression control vibration frequency setting
PB20	VRF2	Vibration suppression control resonance frequency setting
PB21 to PB22		For manufacturer setting
PB23	VFBF	Low-pass filter selection
PB24	*MVS	Slight vibration suppression control selection
PB25		For manufacturer setting
PB26	*CDP	Gain changing selection
PB27	CDL	Gain changing condition
PB28	CDT	Gain changing time constant
PB29	GD2B	Gain changing ratio of load inertia moment to servo motor inertia moment
PB30	PG2B	Gain changing position loop gain
PB31	VG2B	Gain changing speed loop gain
PB32	VICB	Gain changing speed integral compensation
PB33	VRF1B	Gain changing vibration suppression control vibration frequency setting
PB34	VRF2B	Gain changing vibration suppression control resonance frequency setting
PB35 to PB45		For manufacturer setting

APPENDIX

Extension setting parameters (PC□□)			I/O setting parameters (PD□□)																																																								
No.	Symbol	Name	No.	Symbol	Name																																																						
PC01	ERZ	Error excessive alarm level	PD01	/	For manufacturer setting																																																						
PC02	MBR	Electromagnetic brake sequence output	to PD06																																																								
PC03	*ENRS	Encoder output pulses selection	PD07			*D01	Output signal device selection 1 (CN3-pin 13)																																																				
PC04	**COP1	Function selection C-1	PD08			*D02	Output signal device selection 2 (CN3-pin 9)																																																				
PC05	**COP2	Function selection C-2	PD09			*D03	Output signal device selection 3 (CN3-pin 15)																																																				
PC06	*COP3	Function selection C-3	PD010			/	For manufacturer setting																																																				
PC07	ZSP	Zero speed	to PD13																																																								
PC08	/	For manufacturer setting																																																									
PC09	MOD1	Analog monitor output 1	PD14	*D0P3	Function selection D-3																																																						
PC10	MOD2	Analog monitor output 2	PD15	/	For manufacturer setting																																																						
PC11	MO1	Analog monitor 1 offset	to PD32																																																								
PC12	MO2	Analog monitor 2 offset																																																									
PC13	/	For manufacturer setting																																																									
to PC16																																																											
PC17	**COP4	Function selection C-4	<table border="1"> <thead> <tr> <th colspan="3">Extension control parameters (PE□□)</th> </tr> <tr> <th>No.</th> <th>Symbol</th> <th>Name</th> </tr> </thead> <tbody> <tr> <td>PE01</td> <td>**FCT</td> <td>Fully closed loop selection 1</td> </tr> <tr> <td>PE02</td> <td>/</td> <td>For manufacturer setting</td> </tr> <tr> <td>PE03</td> <td>*FCT2</td> <td>Fully closed loop selection 2</td> </tr> <tr> <td>PE04</td> <td>**FBN</td> <td>Fully closed loop feedback pulse electronic gear numerator 1</td> </tr> <tr> <td>PE05</td> <td>**FBD</td> <td>Fully closed loop feedback pulse electronic gear denominator 1</td> </tr> <tr> <td>PE06</td> <td>BC1</td> <td>Fully closed loop control speed deviation error detection level</td> </tr> <tr> <td>PE07</td> <td>BC2</td> <td>Fully closed loop control position deviation error detection level</td> </tr> <tr> <td>PE08</td> <td>DUF</td> <td>Fully closed loop dual feedback filter</td> </tr> <tr> <td>PE09</td> <td>/</td> <td>For manufacturer setting</td> </tr> <tr> <td>PE10</td> <td>FCT3</td> <td>Fully closed loop selection 3</td> </tr> <tr> <td>PE11</td> <td>/</td> <td>For manufacturer setting</td> </tr> <tr> <td>to PE33</td> <td></td> <td></td> </tr> <tr> <td>PE34</td> <td>**FBN2</td> <td>Fully closed loop feedback pulse electronic gear numerator 2</td> </tr> <tr> <td>PE35</td> <td>**FBD2</td> <td>Fully closed loop feedback pulse electronic gear denominator 2</td> </tr> <tr> <td>PE36</td> <td>/</td> <td>For manufacturer setting</td> </tr> <tr> <td>to PE40</td> <td></td> <td></td> </tr> </tbody> </table>			Extension control parameters (PE□□)			No.	Symbol	Name	PE01	**FCT	Fully closed loop selection 1	PE02	/	For manufacturer setting	PE03	*FCT2	Fully closed loop selection 2	PE04	**FBN	Fully closed loop feedback pulse electronic gear numerator 1	PE05	**FBD	Fully closed loop feedback pulse electronic gear denominator 1	PE06	BC1	Fully closed loop control speed deviation error detection level	PE07	BC2	Fully closed loop control position deviation error detection level	PE08	DUF	Fully closed loop dual feedback filter	PE09	/	For manufacturer setting	PE10	FCT3	Fully closed loop selection 3	PE11	/	For manufacturer setting	to PE33			PE34	**FBN2	Fully closed loop feedback pulse electronic gear numerator 2	PE35	**FBD2	Fully closed loop feedback pulse electronic gear denominator 2	PE36	/	For manufacturer setting	to PE40		
Extension control parameters (PE□□)																																																											
No.	Symbol	Name																																																									
PE01	**FCT	Fully closed loop selection 1																																																									
PE02	/	For manufacturer setting																																																									
PE03	*FCT2	Fully closed loop selection 2																																																									
PE04	**FBN	Fully closed loop feedback pulse electronic gear numerator 1																																																									
PE05	**FBD	Fully closed loop feedback pulse electronic gear denominator 1																																																									
PE06	BC1	Fully closed loop control speed deviation error detection level																																																									
PE07	BC2	Fully closed loop control position deviation error detection level																																																									
PE08	DUF	Fully closed loop dual feedback filter																																																									
PE09	/	For manufacturer setting																																																									
PE10	FCT3	Fully closed loop selection 3																																																									
PE11	/	For manufacturer setting																																																									
to PE33																																																											
PE34	**FBN2	Fully closed loop feedback pulse electronic gear numerator 2																																																									
PE35	**FBD2	Fully closed loop feedback pulse electronic gear denominator 2																																																									
PE36	/	For manufacturer setting																																																									
to PE40																																																											
PC18	/	For manufacturer setting																																																									
PC19	/	For manufacturer setting																																																									
PC20	*COP7	Function selection C-7																																																									
PC21	*BPS	Alarm history clear																																																									
PC22	/	For manufacturer setting																																																									
to PC25																																																											
PC26	**COP8	Function selection C-8																																																									
PC27	**COP9	Function selection C-9																																																									
PC28	/	For manufacturer setting																																																									
to PC32																																																											

App. 2 Signal layout recording paper

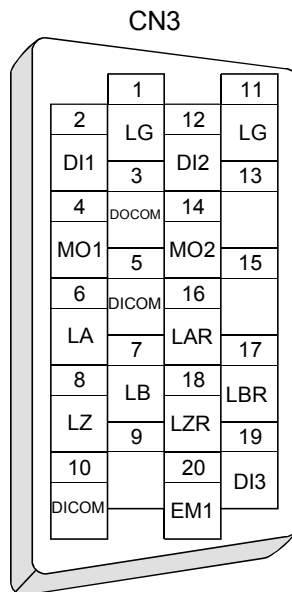

APPENDIX

App. 3 Change of connector sets to the RoHS compatible products

The following connector sets have changed to RoHS compliant since September 2006. RoHS compliant and non-RoHS compliant connector sets may be mixed based on availability. Only the components of the connector set that have changed are listed below.

Model	Current product	RoHS compatible product
MR-J3SCNS	Amplifier connector (3M or equivalent of 3M)	Amplifier connector (3M or equivalent of 3M)
MR-ECNM	36210-0100JL (Receptacle) (Note)	36210-0100PL (Receptacle)

Note. RoHS compatible 36210-0100FD may be packed with current connector sets.

App. 4 MR-J3-200B-RJ006 servo amplifiers manufactured before March 2008

Connectors (CNP1, CNP2, and CNP3) and appearance of MR-J3-200B-RJ006 servo amplifier have been changed from April 2008 production. The difference between new MR-J3-200B-RJ006 servo amplifier and existing servo amplifier is described in this appendix. Sections within parentheses in the following sections indicate corresponding sections of the instruction manual.

App. 4.1 Parts identification (1.8.1 Parts identification)

Name/Application	Detailed explanation
Display The 3-digit, seven-segment LED shows the servo status and alarm number.	Refer to the MR-J3-□B Servo Amplifier Instruction Manual.
Rotary axis setting switch (SW1) SW1 Used to set the axis No. of servo amplifier.	
Test operation select switch (SW2-1) SW2 Used to perform the test operation mode by using MR Configurator. Spare (Be sure to set to the "Down" position).	
Main circuit power supply connector (CNP1) Connect the input power supply.	Section 2.2
USB communication connector (CN5) Connect the personal computer.	Refer to the MR-J3-□B Servo Amplifier Instruction Manual.
I/O signal connector (CN3) Used to connect digital I/O signals. More over an analog monitor is output.	Section 2.3 Section 2.4
Servo motor power connector (CNP3) Connect the servo motor.	Section 2.2
SSCNET III cable connector (CN1A) Used to connect the servo system controller or the front axis servo amplifier.	Refer to the MR-J3-□B Servo Amplifier Instruction Manual.
SSCNET III cable connector (CN1B) Used to connect the rear axis servo amplifier. For the final axis, puts a cap.	
Encoder connector (CN2) Used to connect the servo motor encoder.	Chapter 3
Load side encoder connector (CN2L) Connect the load side encoder.	
Connector for manufacturer setting (CN4) Not used for this servo amplifier.	
Control circuit connector (CNP2) Connect the control circuit power supply/regenerative option.	Section 2.2
Battery holder Not used for this servo amplifier.	
Charge lamp Lit to indicate that the main circuit is charged. While this lamp is lit, do not reconnect the cables.	
Protective earth (PE) terminal (⊕) Ground terminal.	Section 2.2
Rating plate	Section 1.6

Fixed part (3 places)

App. 4.2 Configuration including auxiliary equipment (1.9 Configuration including auxiliary equipment)

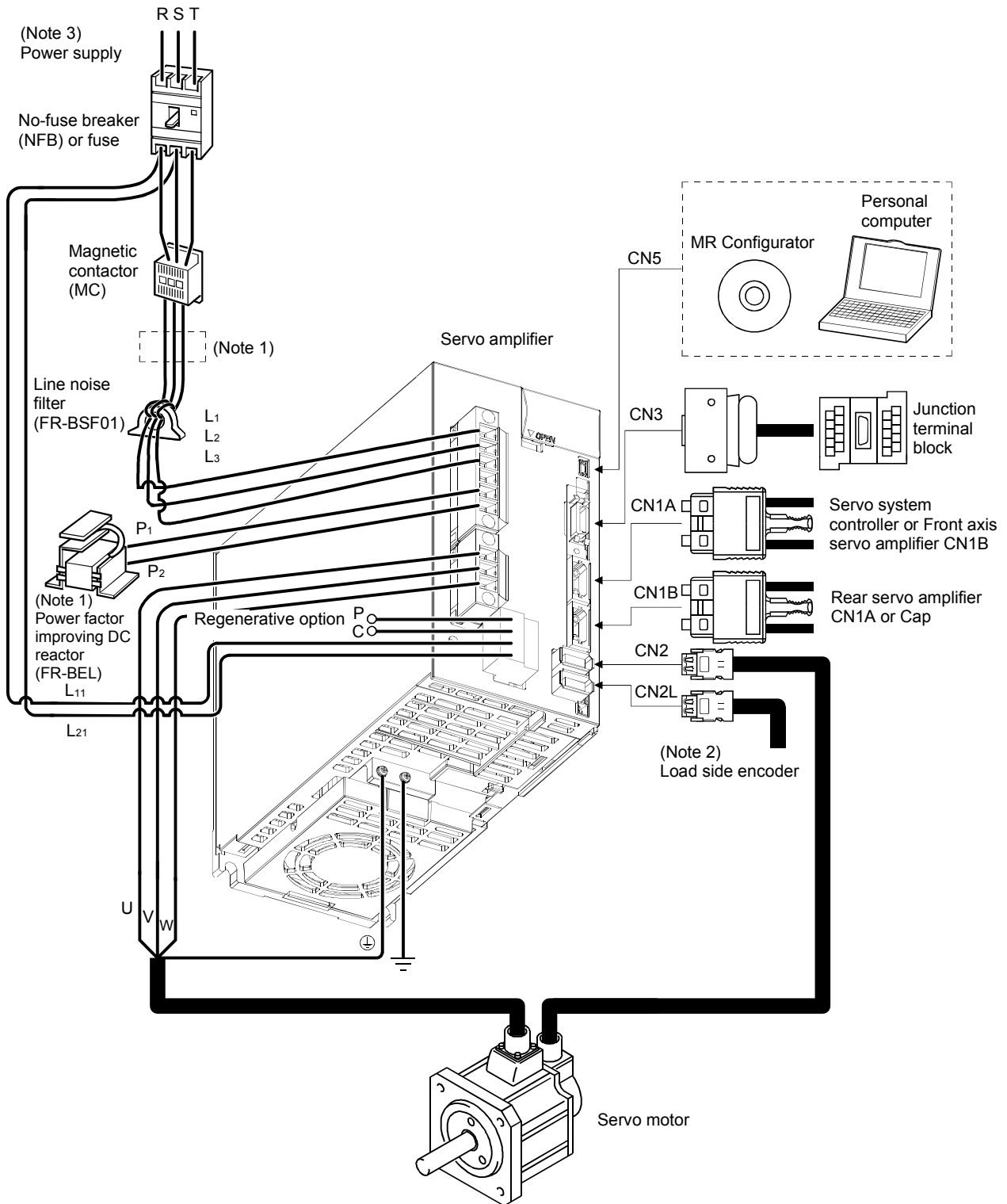

- Note 1. The power factor improving AC reactor can also be used. In this case, the power factor improving DC reactor cannot be used. When not using the power factor improving DC reactor, short P₁ and P₂.
2. For the configuration of the ABZ-phase pulse train interface or serial communication specification linear encoder/rotary encoder, refer to section 1.10.
3. Refer to section 1.3 for the power supply specification.

App. 5 Compliance with the european EC directives

App. 5.1 What are EC directives?

The EC directives were issued to standardize the regulations of the EU countries and ensure smooth distribution of safety-guaranteed products. In the EU countries, the machinery directive (effective in January, 1995), EMC directive (effective in January, 1996) and low voltage directive (effective in January, 1997) of the EC directives require that products to be sold should meet their fundamental safety requirements and carry the CE marks (CE marking). CE marking applies also to machines and equipment into which servos have been installed.

(1) EMC directive

The EMC directive applies to the servo units alone. This servo is designed to comply with the EMC directive. The EMC directive also applies the servo-incorporated machines and equipment. This requires the EMC filters to be used with the servo-incorporated machines and equipment to comply with the EMC directive. For specific EMC directive conforming methods, refer to the EMC Installation Guidelines (IB(NA)67310).

(2) Low voltage directive

The low voltage directive applies also to servo units alone. This servo is designed to comply with the low voltage directive.

(3) Machine directive

Not being machines, the servo amplifiers need not comply with this directive.

App. 5.2 For compliance

(1) Servo amplifiers and servo motors used

Use the servo amplifiers and servo motors which standard product.

Servo amplifier : MR-J3-10B-RJ006 to MR-J3-22KB-RJ006
 MR-J3-10B1-RJ006 to MR-J3-40B1-RJ006
 MR-J3-60B4-RJ006 to MR-J3-22KB4-RJ006

Servo motor series : HF-MP□ · HF-KP□ · HF-SP□ · HF-SP□4 · HC-RP□ · HC-UP□ ·
 HC-LP□ · HA-LP□ · HA-LP□4

(2) Structure

The control circuit provide safe separation to the main circuit in the servo amplifier.

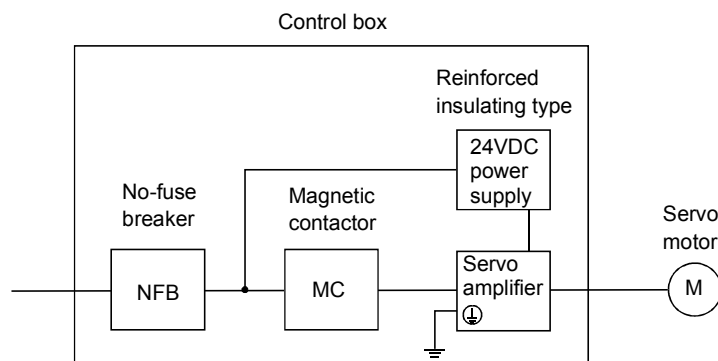

APPENDIX

(3) Environment

(a) Operate the servo amplifier at or above pollution degree 2 set forth in IEC/EN 60664-1. For this purpose, install the servo amplifier in a control box which is protected against water, oil, carbon, dust, dirt, etc. (IP54).

(b) Environment

Environment		Conditions	
(Note 1) Ambient Temperature	In operation	[°C]	(Note 2) 0 to 55
		[°F]	32 to 131
	In storage, In transportation	[°C]	-20 to 65
		[°F]	-4 to 149
Ambient Humidity	In operation, In storage, In transportation	90% RH or less	
Maximum Altitude	In operation, In storage	1000m or less	
	In transportation	10000m or less	

Note 1. Ambient temperature is the internal temperature of the control box.

2. The servo amplifier 200V 3.5kW or less and 100V 400W or less can be mounted closely. In this case, keep the ambient temperature within 0 to 45°C (32 to 113°F) or use the servo amplifier with 75% or less of the effective load ratio.

(4) Power supply

(a) This servo amplifier can be supplied from star-connected supply with earthed neutral point of overvoltage category III set forth in IEC/EN 60664-1. However, when using the neutral point of 400V system for single phase supply, a reinforced insulating transformer is required in the power input section.

(b) For the interface power supply, use a 24VDC power supply with reinforced insulation on I/O terminals.

(5) Grounding

(a) To prevent an electric shock, the protective earth (PE) terminal (marked ⊕) of the servo amplifier must be connected to the protective earth (PE) of the control box.

(b) Do not connect two ground cables to the same protective earth (PE) terminal. Always connect cables to the terminals one-to-one.

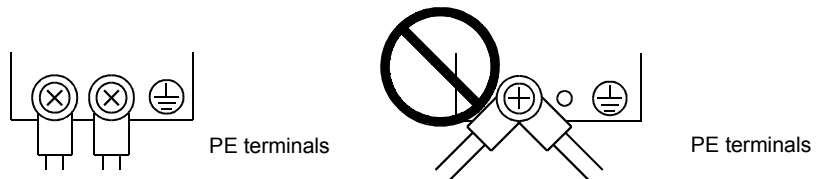

(c) If an earth leakage circuit breaker is used, always earth the protective earth (PE) terminal of the servo amplifier to prevent an electric shock.

(6) Wiring

- (a) The cables to be connected to the terminal block of the servo amplifier must have crimping terminals provided with insulating tubes to prevent contact with adjacent terminals.

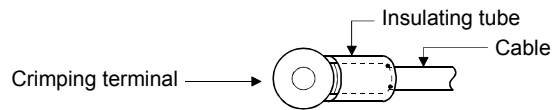

- (b) Use the servo motor side power connector which complies with the IEC/EN Standard. The IEC/EN Standard-compliant power connector sets are available from us as options.
- (c) The servo amplifier must install in the metal cabinet (control box).

(7) Peripheral devices, options

- (a) Use the circuit breaker and magnetic contactor models which are IEC/EN Standard-compliant products given in section 11.2 of the MR-J3-□B Servo Amplifier Instruction Manual.

Use a type B (Note) breaker. When it is not used, provide insulation between the servo amplifier and other device by double insulation or reinforced insulation, or install a transformer between the main power supply and servo amplifier.

Note. Type A: AC and pulse detectable

Type B: Both AC and DC detectable

- (b) The sizes of the wires given in section 11.11 of the MR-J3-□B Servo Amplifier Instruction Manual meet the following conditions. For use in any other conditions, follow Table 5 and Annex C of IEC/EN 60204-1.
- Ambient temperature : 40°C (104°F)
 - Sheath : PVC (polyvinyl chloride)
 - Installation on wall surface or open table tray

- (c) Use the EMC filter for noise reduction.

(8) Performing EMC tests

When EMC tests are run on a machine/device into which the servo amplifier has been installed, it must conform to the electromagnetic compatibility (immunity/emission) standards after it has satisfied the operating environment/electrical equipment specifications.

For the other EMC directive guidelines on the servo amplifier refer to the EMC Installation Guidelines (IB(NA)67310).

APPENDIX

App. 6 Compliance with UL/C-UL standard

This servo amplifier is designed to comply with UL 508C, CSA C22.2 No.14.

(1) Servo amplifiers and servo motors used

Use the servo amplifiers and servo motors which standard product.

Servo amplifier	Servo motor						
	HF-KP	HF-MP	HF-SP	HC-RP	HC-UP	HC-LP	HA-LP
MR-J3-10B(1)-RJ006	053 · 13	053 · 13					
MR-J3-20B(1)-RJ006	23	23					
MR-J3-40B(1)-RJ006	43	43					
MR-J3-60B-RJ006			51 · 52			52	
MR-J3-70B-RJ006	73	73			72		
MR-J3-100B-RJ006			81 · 102			102	
MR-J3-200B-RJ006			121 · 201 · 152 · 202	103 · 153	152	152	
MR-J3-350B-RJ006			301 · 352	203	202	202	
MR-J3-500B-RJ006			421 · 502	353 · 503	352 · 502	302	502
MR-J3-700B-RJ006			702				601 · 701M · 702
MR-J3-11KB-RJ006							801 · 12K1 · 11K1M · 11K2
MR-J3-15KB-RJ006							15K1 · 15K1M · 15K2
MR-J3-22KB-RJ006							20K1 · 25K1 · 22K1M · 22K2

Servo amplifier	Servo motor	
	HF-SP	HA-LP
MR-J3-60B4-RJ006	524	
MR-J3-100B4-RJ006	1024	
MR-J3-200B4-RJ006	1524 · 2024	
MR-J3-350B4-RJ006	3524	
MR-J3-500B4-RJ006	5024	
MR-J3-700B4-RJ006	7024	6014 · 701M4
MR-J3-11KB4-RJ006		8014 · 12K14 · 11K1M4 · 11K24
MR-J3-15KB4-RJ006		15K14 · 15K1M4 · 15K24
MR-J3-22KB4-RJ006		20K14 · 22K1M4 · 22K24

APPENDIX

(2) Installation

The MR-J3 series have been approved as the products which have been installed in the electrical enclosure.

The minimum enclosure size is based on 150% of each MR-J3 combination.

And also, design the enclosure so that the ambient temperature in the enclosure is 55°C (131°F) or less, refer to the spec manual.

The servo amplifier must install in the metal cabinet (control box).

(3) Short circuit rating (SCCR: Short Circuit Current Rating)

Suitable For Use In A Circuit Capable Of Delivering Not More Than 100 kA rms Symmetrical Amperes, 500 Volts Maximum.

(4) Flange

Mount the servo motor on a flange which has the following size or produces an equivalent or higher heat dissipation effect.

Flange size [mm]	Servo motor					
	HF-MP HF-KP	HF-SP	HC-RP	HC-UP	HC-LP	HA-LP
250 × 250 × 6	053 · 13 · 23					
250 × 250 × 12	43	51 · 81 52(4) to 152(4)	103 to 203		52 to 152	
300 × 300 × 12	73					
300 × 300 × 20		121 · 201 202(4) · 352(4)			202 · 302	
550 × 550 × 30			353 · 503	72 · 152		
650 × 650 × 35		502(4) · 702(4)		202 to 502		601 to 12K1 8014 to 12K14 701M(4) to 15K1M(4) 502 to 22K2 11K24 to 22K24
950 × 950 × 35						15K1 to 25K1 15K14 to 20K14 22K1M · 22K1M4

(5) About wiring protection

For installation in United States, branch circuit protection must be provided, in accordance with the National Electrical Code and any applicable local codes.

For installation in Canada, branch circuit protection must be provided, in accordance with the Canada Electrical Code and any applicable provincial codes.

APPENDIX

(6) Options, peripheral devices

Use the UL/C-UL Standard-compliant products.

Use the no-fuse breaker (UL489 Listed MCCB) or a Class T fuse indicated in the table below.

Servo amplifier	No-fuse breaker (Note)		Fuse	
	Current	Voltage AC	Current	Voltage AC
MR-J3-10B(1)-RJ006 · 20B-RJ006	30A frame 5A	240V	10A	300V
MR-J3-40B-RJ006 · 20B1-RJ006	30A frame 10A		15A	
MR-J3-60B-RJ006 to 100B-RJ006 · 40B1-RJ006	30A frame 15A		20A	
MR-J3-200B-RJ006	30A frame 20A		40A	
MR-J3-350B-RJ006	30A frame 30A		70A	
MR-J3-500B-RJ006	50A frame 50A		125A	
MR-J3-700B-RJ006	100A frame 75A		150A	
MR-J3-11KB-RJ006	100A frame 100A		200A	
MR-J3-15KB-RJ006	225A frame 125A		250A	
MR-J3-22KB-RJ006	225A frame 175A		350A	
MR-J3-60B4-RJ006	30A frame 5A	600Y/347V	10A	600V
MR-J3-100B4-RJ006	30A frame 10A		15A	
MR-J3-200B4-RJ006	30A frame 15A		25A	
MR-J3-350B4-RJ006	30A frame 20A		35A	
MR-J3-500B4-RJ006	30A frame 30A		50A	
MR-J3-700B4-RJ006	50A frame 40A		65A	
MR-J3-11KB4-RJ006	60A frame 60A		100A	
MR-J3-15KB4-RJ006	100A frame 75A		150A	
MR-J3-22KB4-RJ006	225A frame 125A		175A	

Note. Listed no-fuse breakers are for when the power factor improving reactor is not used.

(7) Capacitor discharge time

The capacitor discharge time is as follows. To ensure safety, do not touch the charging section for 15 minutes after power-off.

Servo amplifier	Discharge time (min)
MR-J3-10B-RJ006 · 20B-RJ006	1
MR-J3-40B-RJ006 · 60B(4)-RJ006 · 10B1-RJ006 · 20B1-RJ006	2
MR-J3-70B-RJ006	3
MR-J3-40B1-RJ006	4
MR-J3-100B(4)-RJ006	5

Servo amplifier	Discharge time (min)
MR-J3-200B(4)-RJ006 · 350B-RJ006	9
MR-J3-350B4-RJ006 · 500B(4)-RJ006 · 700B(4)-RJ006	10
MR-J3-11KB(4)-RJ006	4
MR-J3-15KB(4)-RJ006	6
MR-J3-22KB(4)-RJ006	8

APPENDIX

(8) Selection example of wires

To comply with the UL/C-UL Standard, use UL-approved copper wires rated at 60/75°C (140/167°F) for wiring.

The following table shows the wire sizes [AWG] and the crimping terminal symbols rated at 60°C (140°F). The sizes and the symbols rated at 75°C (167°F) are shown in the brackets.

Servo amplifier	(Note 3) Wires [mm ²]			
	L ₁ · L ₂ · L ₃ · ⊕	L ₁₁ · L ₂₁	U · V · W · P ₁ · P ₂ · ⊕	P · P ₂ · C
MR-J3-10B(1)-RJ006 to 40B(1)-RJ006 · 60B-RJ006 · 70B-RJ006	14(14)	16(16)	(Note 4) 14(14)	14(14)
MR-J3-100B-RJ006 · 200B-RJ006				
MR-J3-350B-RJ006	12(12)		12(12)	
(Note 1) MR-J3-500B-RJ006	10(10): a(a)	16(16): h(h)	10(10): a(a)	14(14): g(g)
(Note 1) MR-J3-700B-RJ006	8(8): b(b)		8(8): b(b)	12(12): a(a)
(Note 1) MR-J3-11KB-RJ006	6(6): c(c)	16(16): g(g)	4(4): d(c)	10(10): j(j)
(Note 1) MR-J3-15KB-RJ006	4(4): d(d)		2(3): e(d)	
(Note 1) MR-J3-22KB-RJ006	1/0(1): f(p)		-(1): -(p)	10(10): k(k)
MR-J3-60B4-RJ006	14(14)	16(16)	14(14)	14(14)
MR-J3-100B4-RJ006				
MR-J3-200B4-RJ006				
MR-J3-350B4-RJ006	14(14): g(g)	16(16): h(h)	14(14): g(g)	14(14): g(g)
(Note 1) MR-J3-500B4-RJ006	10(12): a(a)		10(12): a(a)	
(Note 1) MR-J3-700B4-RJ006	10(10): a(a)		10(10): a(a)	
(Note 1) MR-J3-11KB4-RJ006	8(10): l(j)	16(16): g(g)	8(8): l(l)	12(12): j(j)
(Note 1) MR-J3-15KB4-RJ006	6(8): c(l)		4(6): d(c)	10(10): j(j)
(Note 1) MR-J3-22KB4-RJ006	6(6): m(m)		4(6): n(m)	10(10): k(k)

Servo amplifier	Wires [mm ²]		
	B1 · B2	BU · BV · BW	OHS1 · OHS2
MR-J3-10B(1)-RJ006 to 40B(1)-RJ006 · 60B-RJ006 · 70B-RJ006	16(16)		
MR-J3-100B-RJ006 · 200B-RJ006			
MR-J3-350B-RJ006			
(Note 1) MR-J3-500B-RJ006			
(Note 1) MR-J3-700B-RJ006		(Note 2) 14(14)	(Note 2) 16(16)
(Note 1) MR-J3-11KB-RJ006			
(Note 1) MR-J3-15KB-RJ006		14(14)	16(16)
(Note 1) MR-J3-22KB-RJ006			
MR-J3-60B4-RJ006			
MR-J3-100B4-RJ006			
MR-J3-200B4-RJ006			
MR-J3-350B4-RJ006			
(Note 1) MR-J3-500B4-RJ006			
(Note 1) MR-J3-700B4-RJ006		(Note 2) 14(14)	(Note 2) 16(16)
(Note 1) MR-J3-11KB4-RJ006			
(Note 1) MR-J3-15KB4-RJ006		14(14)	16(16)
(Note 1) MR-J3-22KB4-RJ006			

Note 1. To connect these models to a terminal block, be sure to use the screws that come with the terminal block.

2. For the servo motor with a cooling fan.

3. Alphabets in the table indicate crimping tools. Refer to the following table for the crimping terminals and crimping tools.

4. To wire the servo amplifier and a HF-MP · KP servo motor, use the MR-PWS1CBL (option). To extend the wiring, use the AWG14 wire size.

APPENDIX

Table: Recommended crimping terminals

Symbol	Servo amplifier side crimping terminals				Manufacturer
	(Note 2) Crimping terminal	Applicable tool			
		Body	Head	Dice	
a	FVD5.5-4	YNT-1210S			Japan Solderless Terminal
(Note 1) b	8-4NS	YHT-8S			
c	FVD14-6	YF-1 · E-4	YNE-38	DH-122 · DH-112	
d	FVD22-6			DH-123 · DH-113	
(Note 1) e	38-6	YPT-60-21	YET-60-1	TD-124 · TD-112	
		YF-1 · E-4			
(Note 1) f	R60-8	YPT-60-21	YET-60-1	TD-125 · TD-113	
		YF-1 · E-4			
g	FVD2-4	YNT-1614			
h	FVD2-M3				
j	FVD5.5-6				
k	FVD5.5-8				
l	FVD8-6	YF-1 · E-4	YNE-38	DH-121 · DH-111	
m	FVD14-8			DH-122 · DH-112	
n	FVD22-8			DH-123 · DH-113	
(Note 1) p	R38-8			YPT-60-21	YET-60-1
		YF-1 · E-4			
q	FVD2-6	YNT-1614			

Note 1. Coat the part of crimping with the insulation tube.

- Some crimping terminals may not be mounted depending on the size. Make sure to use the recommended ones or equivalent ones.

(9) Terminal block tightening torque

Servo amplifier	Tightening torque [N · m]					
	TE1	TE2	TE3	PE	L ₁ /L ₂ /L ₃ / U/V/W/ P ₁ /P/C/N	L ₁₁ /L ₁₂
MR-J3-10B(1)-RJ006 to 40B(1)-RJ006 · 60B-RJ006 to 100B-RJ006 · 60B4-RJ006 · 100B4-RJ006 · 200B(4)-RJ006 · 350B-RJ006	1.2	0.8	1.2	1.2	1.2	0.8
MR-J3-350B4-RJ006 · 500B(4)-RJ006 · 700B(4)-RJ006						
MR-J3-11KB(4)-RJ006 · 15KB(4)-RJ006	3.0	3.0	3.0	3.0	3.0	1.2
MR-J3-22KB(4)-RJ006						

APPENDIX

(10) Overload protection characteristics

An electronic thermal relay is built in the servo amplifier to protect the servo motor and servo amplifier from overloads. The operation characteristics of the electronic thermal relay are shown below. It is recommended to use an unbalanced torque-generated machine, such as a vertical motion shaft, so that unbalanced torque is not more than 70% of the rated torque. When you carry out adhesion mounting of the servo amplifier, make circumference temperature into 0 to 45°C (32 to 113°F) or use it with 75% or less of effective load torque.

Servo amplifier MR-J3 series has solid-state servo motor overload protection. (The motor full load current is 115% rated current.)

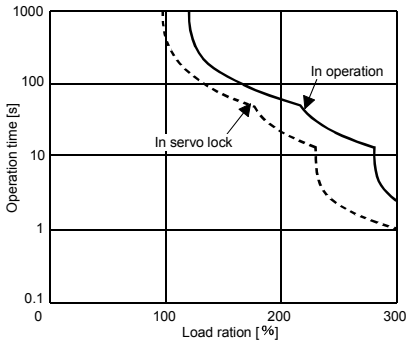

MR-J3-10B(1)-RJ006

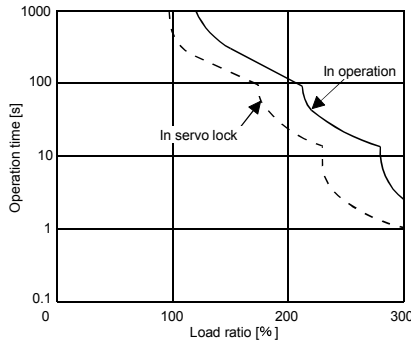

MR-J3-20B(1)-RJ006 ·
MR-J3-40B(1)-RJ006
MR-J3-60B(4)-RJ006 to
MR-J3-100B(4)-RJ006

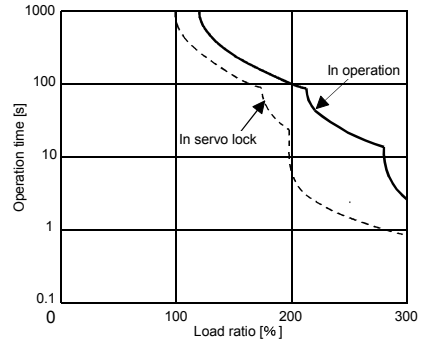

MR-J3-200B(4)-RJ006 ·
MR-J3-350B(4)-RJ006

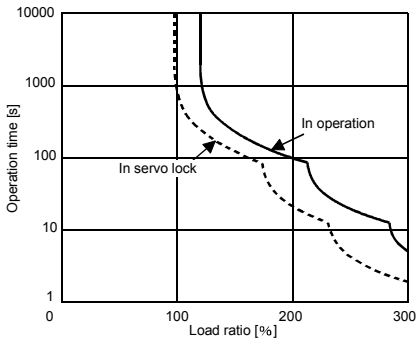

MR-J3-500B(4)-RJ006 ·
MR-J3-700B(4)-RJ006

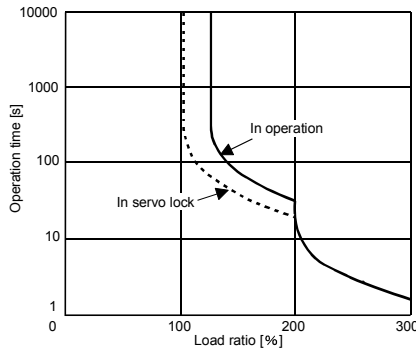

MR-J3-11KB(4)-RJ006 to
MR-J3-22KB(4)-RJ006

(11) Figure configuration

Representative configuration example to conform to the UL/C-UL standard is shown below. The earth wiring is excluded from the figure configuration.

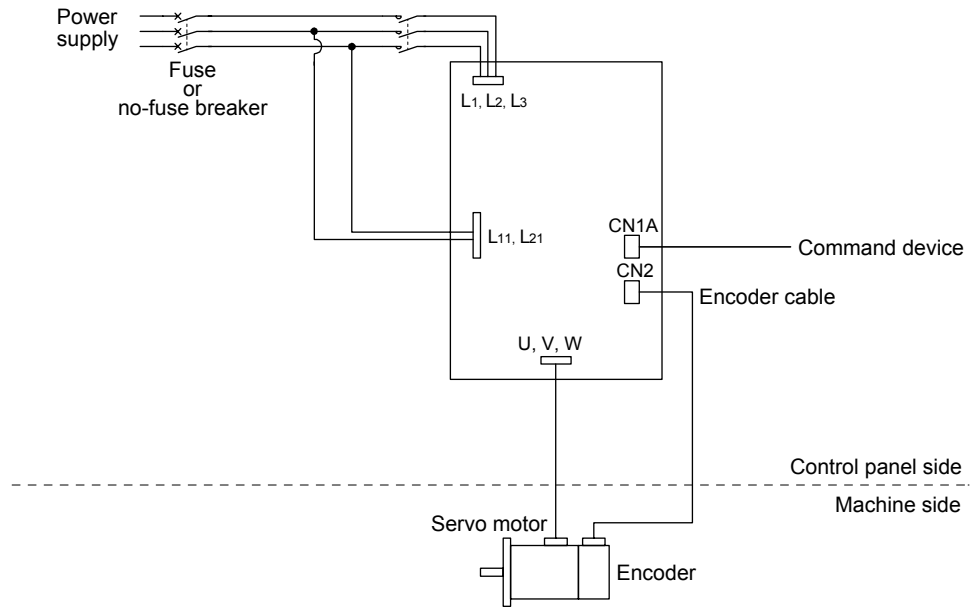

REVISIONS

*The manual number is given on the bottom left of the back cover.

Print Data	*Manual Number	Revision
Mar, 2006	SH(NA)030056-A	First edition
Nov., 2007	SH(NA)030056-B	<p>Safety Instructions</p> <p>1.To prevent electric shock Part of sentences changed</p> <p>2.To prevent fire Part of sentences changed</p> <p>4.Additional instructions (1) Table partially changed</p> <p>4.Additional instructions (2) Sentence added</p> <p>Compliance with EC directives</p> <p>2.Precautions for compliance (1) Servo amplifiers MR-J3-60B4-RJ006 to MR-J3-22KB4-RJ006 added Servo motor HF-SP4 added</p> <p>Conformance with UL/C-UL Standard (1) Servo amplifiers MR-J3-60B4-RJ006 to MR-J3-22KB4-RJ006 added Servo motor HF-SP4 added</p> <p>Conformance with UL/C-UL Standard (4) 400V class servo amplifier added</p> <p>Conformance with UL/C-UL Standard (5) Part added in table</p> <p>Section 1.3 (2) Servo amplifiers MR-J3-60B4-RJ006 to MR-J3-700B4-RJ006 added in table Note added</p> <p>Section 1.6 (2) Drawings of MR-J3-60B4-RJ006, MR-J3-100B4-RJ006 and MR-J3-200B4-RJ006 added</p> <p>Section 1.7 Servo amplifiers MR-J3-60B4-RJ006 to MR-J3-700B4-RJ006 added in table</p> <p>Section 1.8.1 (2) MR-J3-60B4-RJ006, 100B4-RJ006 added (4) MR-J3-200B4-RJ006 added 350B4, 500B(4), 700B(4) and 11KB(4) to 22KB(4) added</p> <p>Section 1.8.2 CAUTION changed to WARNING, and sentence changed</p> <p>Section 1.9 (1)(a) Note sentence partially changed</p> <p>Section 1.9 (2) MR-J3-60B4-RJ006 and MR-J3-100B4-RJ006 added (4) MR-J3-200B4-RJ006 added</p> <p>Chapter 2 WARNING partially changed</p> <p>Section 2.2 CAUTION partially changed POINT sentence added (3) Diagram for "For MR-J3-10B1-RJ006 to MR-J3-40B1-RJ006" changed (4) MR-J3-60B4-RJ006 to MR-J3-200B4-RJ006 added</p> <p>Section 2.2 (5) Cooling fan power supply added to diagram Note added (6) MR-J3-350B4-RJ006 to MR-J3-700B4-RJ006 added</p> <p>Section 2.2 (7) Note changed</p> <p>Section 2.2 (8) Note changed</p>

Print Data	*Manual Number	Revision	
Nov., 2007	SH(NA)030056-B	Section 2.4	Connector pin layout figure changed
		Section 3.1	"ST743" and "LC192M" added to linear encoder list and partially changed
		Section 3.2.1 (1)	Linear scale "ST743" added
		Section 3.2.1 (3)	Linear scale "ST743" added in table
		(c)	
		Section 3.2.1 (4)	Connector pin layout figure changed
		(a) 2)	
		Section 3.2.1 (4)	Connector pin layout figure changed
		(b) 2)	
		Section 3.2.1 (4)	Connector pin layout figure changed
		2)	
		Section 3.2.2 (1)	Linear encoder "LC192M" added
		(a)	
		Section 3.2.2 (3)	(b) LC192M (absolute position type) added
		Section 3.2.2 (4)	Linear encoder "LC192M" added in table
		(a) 1)	
		Section 3.2.2 (4)	Connector pin layout figure changed
		(a) 2)	
		Section 3.2.2 (4)	Connector pin layout figure changed
		(b) 2)	
		Section 3.2.3 (4)	POINT sentence added
		1)	
		Section 3.2.3 (4)	Connector pin layout figure changed
		2)	
		Section 3.2.4 (4)	Connector pin layout figure changed
		2)	
		Section 3.3 (3) 2)	POINT sentence added
		Section 3.4.3	Connector pin layout figure changed
		Section 4.1.5(2)	Error of formula for electronic gear setting method corrected
		Section 5.2	Error of name for parameter No.PB17 corrected
		Section 5.3.2	Name for parameter No.PC01 and sentence in Function column partially changed, and Note added
		Section 5.3.3 (3)	Block diagram partially changed
		Section 5.5.1	Error of name for parameter No.PE06 corrected
			Error of name for parameter No.PE07 corrected
		Section 5.5.2	Parameter No.PE02 added
			Sentence in Definition column of Display 28 changed
		Section 6.2	Cause of Display 70 and 71 partially changed
		Section 6.3	Alarms for ST741/ST743 added in table
		Chapter 7	(4) MR-J3-60B4-RJ006 and MR-J3-100B4-RJ006 added
			(6) MR-J3-200B4-RJ006 added
		Chapter 7 (7)	Note added
		Chapter 7 (8)	Note added
		App. 1	Error of name for parameter No.PA10 corrected
			Error of name for parameter No.PB17 corrected
		App. 3	Addition of List of RoHS Compatible Product
May, 2008	SH(NA)030056-C	(2) Wiring	"Otherwise, the servo motor may misoperate." changed to "Otherwise, the servo motor may operate unexpectedly."

Print Data	*Manual Number	Revision	
May, 2008	SH(NA)030056-C	(2) Wiring	"Connect the output terminals (U, V, W) correctly. Otherwise, the servo motor will operate improperly" changed to "Connect the wires to the correct phase terminals (U, V, W) of the servo amplifier and servo motor. Not doing so may cause unexpected operation."
		CONFORMANCE WITH UL/C-UL STANDARD	Description of (3) Short circuit rating changed
		About the wires used for wiring	Selection base temperature listed
		Section 1.3 (1)	Mass of MR-J3-200B-RJ006 changed from "2.3" to "2.1"
		Section 1.3 (2)	(Note 2) added
		Section 1.6 (2)	Case of MR-J3-200B-RJ006 shared with MR-J3-B4-RJ006
		Section 1.8.1 (3), (4)	(3) and (4) switched, MR-J3-200B-RJ006 shared with MR-J3-200B4-RJ006, Note added to (3)
		Section 1.9 (3), (4)	(3) and (4) switched, MR-J3-200B-RJ006 shared with MR-J3-200B4-RJ006, Note 4 added to (3)
		Chapter 2	"Otherwise, the servo motor may misoperate, resulting in injury." changed to "Otherwise, the servo motor may operate unexpected resulting in injury."
		Chapter 2 (1)	"N" of CNP1 changed to "N(-)" in wiring diagram "P" of CNP2 changed to "P(+)" in wiring diagram "Always connect P and D" in Note 2 changed to "Always connect P(+) and D"
		Section 2.3	Description changed to a description with the following signal assignment for DI1, DI2 and DI3 DI1: Upper stroke limit, DI2: Lower stroke limit, DI3: Proximity dog (DOG) Connection example of DI1 and DI2 changed to "Normally-closed contact"
		Section 4.3	Description of Note15 changed "QD75MH□" added as compatible controller Motion controller model "Q172HCPU/Q173HCPU" changed to "Q17□DCPU/Q17□HCPU" in table
		Section 4.3.2	Title "Controller setting (motion controller)" changed to "Servo system controller setting" Motion controller model "Q172HCPU/Q173HCPU" changed to "Q17□DCPU/Q17□HCPU" in table "QD75MH□" added under Settings in table
		Chapter 7	(5) and (6) switched, MR-J3-200B-RJ006 shared with MR-J3-200B4-RJ006, POINT added to (5)
		Appendix 4	"MR-J3-200B-RJ006 servo amplifiers manufactured before March 2008" added
Aug., 2009	SH(NA)030056-D	Electronic symbols changed throughout the manual (JIS C0617 compliant) "Servo motor Instruction Manual" changed to "Servo motor Instruction Manual (Vol.2)" "Absolute position system" changed to "absolute position detection system" AC reactor changed to power improving AC reactor to be consistent DC reactor changed to power improving DC reactor to be consistent 4. Additional Vibration condition added Instructions (1)	

Print Data	*Manual Number	Revision	
Aug., 2009	SH(NA)030056-D	4. Additional Instructions (2)	NFB changed to MC in the figure
		4. Additional Instructions (5)	Figure changed
		Conformance with UL/C-UL Standard	Contents changed in (2)Installation and (3)Short circuit rating Description of conformance with the standard changed Description of <About the wires used for wiring> moved
		Section 1.3 (1)	Item of "Mounting closely" added Vibration condition added Item of "Output" added Rated current with item of "Power supply input" added Maximum current with item of "Control circuit power supply input" added Note changed
		Section 1.3 (2)	Vibration condition added Item of "Output" added Rated current with item of "Power supply input" added Maximum current with item of "Control circuit power supply input" added
		Section 1.4	Items of "Robust disturbance compensation", "Advanced Gain search", and "Input signal selection (Device settings)" added
		Section 1.5.1	Parameter No.PE08 value changed
		Section 1.6 (2)	Note (Note 3) added above 4 in the power supply symbol section
		Section 1.7	"The same combinations apply to the models with electromagnetic brakes" changed to "The same combinations apply to the models with an electromagnetic brake and the models with a reduction gear"
		Section 2.1	Items of "Alarm occurrence timing chart (section 3.6)" and "Grounding (section 3.12)" added
		Section 2.2 (1) to (6)	Figures of connection between the servo amplifier and the servo motor changed
		Section 2.2 (1), (2), (4) to (8)	"Use only one of power factor improving DC reactor or power factor improving AC reactor" added at the end of the paragraph
		Section 2.2 (1) to (3)	Note 8 and Note 9 added
		Section 2.2 (4)	Note 9 and Note 10 added
		Section 2.2 (5), (7)	Note 9 and Note 10 added NFB added between Cooling fan and Cooling fan power supply
		Section 2.2 (6)	Note 10 and Note 11 added NFB added between Cooling fan and Cooling fan power supply
		Section 2.2 (8)	Note 11 and Note 12 added NFB added between Cooling fan and Cooling fan power supply
		Section 2.3	Note 11 sentence partially changed Description of "Q170MCP" and "QD74MH□" added to Note
		Section 2.4	Sentence below POINT section changed "For the appearances and connector... refer to the outline drawings of servo amplifier in chapter 6" changed to "...refer to chapter 7 OUTLINE DRAWINGS" Reference for the detail of CN5(USB connector) changed "Refer to section 11.6 of the MR-J3-□B Servo Amplifier Instruction Manual" changed to "Refer to section 11.8 of the MR-J3-□B Servo Amplifier Instruction Manual"

Print Data	*Manual Number	Revision	
Aug., 2009	SH(NA)030056-D	Section 2.5 Section 3.1 Section 3.2.1 (4) (c) 1) Section 3.2.2 (1) (b) Section 4.3 Section 4.3.2 Section 5.3.1 Section 5.3.2 Section 5.3.3 Section 5.3.3 (3) Section 6.1 Section 6.2 Chapter 7 (3), (5) to (9) Appendix 1 Appendix 4.3 Appendix 5 Appendix 6	D11 and D12 changed to b contact Note 3 added Linear encoder SH13 deleted(Production discontinuation) Figure partially changed Reference changed from "(5) in this section" to "(4) in this section" Description of "Q170MCP" and "QD74MH□" added Description of "Q170MCP" and "QD74MH□" added Description of "Function selection C-7" added to No.PC20 "Encoder error 2 (71)" changed to "load side encoder error 2 (71)" Sentence partially changed "Full closed loop" changed to "Fully closed loop" "Encoder error 2"changed to "Encoder error 2 (During runtime)" "Display 21 Encoder error 3 (During runtime)" added "Encoder error 2"changed to "Encoder error 2 (During runtime)" "Display 21 Encoder error 3 (During runtime)" added "Cooling fan wind direction" changed to "Cooling fan air intake (exhaust)" "Air exhaust (intake)" added Description of "Function selection C-7" added to No.PC20 "Cooling fan wind direction" changed to "Cooling fan air intake" "Air exhaust" added "Compliance with the european EC directives" added "Compliance with UL/C-UL standard" added

Warranty

1. Warranty period and coverage

We will repair any failure or defect hereinafter referred to as "failure" in our FA equipment hereinafter referred to as the "Product" arisen during warranty period at no charge due to causes for which we are responsible through the distributor from which you purchased the Product or our service provider. However, we will charge the actual cost of dispatching our engineer for an on-site repair work on request by customer in Japan or overseas countries. We are not responsible for any on-site readjustment and/or trial run that may be required after a defective unit are repaired or replaced.

[Term]

The term of warranty for Product is twelve (12) months after your purchase or delivery of the Product to a place designated by you or eighteen (18) months from the date of manufacture whichever comes first ("Warranty Period"). Warranty period for repaired Product cannot exceed beyond the original warranty period before any repair work.

[Limitations]

- (1) You are requested to conduct an initial failure diagnosis by yourself, as a general rule.
It can also be carried out by us or our service company upon your request and the actual cost will be charged. However, it will not be charged if we are responsible for the cause of the failure.
- (2) This limited warranty applies only when the condition, method, environment, etc. of use are in compliance with the terms and conditions and instructions that are set forth in the instruction manual and user manual for the Product and the caution label affixed to the Product.
- (3) Even during the term of warranty, the repair cost will be charged on you in the following cases:
 - (i) a failure caused by your improper storing or handling, carelessness or negligence, etc., and a failure caused by your hardware or software problem
 - (ii) a failure caused by any alteration, etc. to the Product made on your side without our approval
 - (iii) a failure which may be regarded as avoidable, if your equipment in which the Product is incorporated is equipped with a safety device required by applicable laws and has any function or structure considered to be indispensable according to a common sense in the industry
 - (iv) a failure which may be regarded as avoidable if consumable parts designated in the instruction manual, etc. are duly maintained and replaced
 - (v) any replacement of consumable parts (battery, fan, smoothing capacitor, etc.)
 - (vi) a failure caused by external factors such as inevitable accidents, including without limitation fire and abnormal fluctuation of voltage, and acts of God, including without limitation earthquake, lightning and natural disasters
 - (vii) a failure generated by an unforeseeable cause with a scientific technology that was not available at the time of the shipment of the Product from our company
 - (viii) any other failures which we are not responsible for or which you acknowledge we are not responsible for

2. Term of warranty after the stop of production

- (1) We may accept the repair at charge for another seven (7) years after the production of the product is discontinued. The announcement of the stop of production for each model can be seen in our Sales and Service, etc.
- (2) Please note that the Product (including its spare parts) cannot be ordered after its stop of production.

3. Service in overseas countries

Our regional FA Center in overseas countries will accept the repair work of the Product. However, the terms and conditions of the repair work may differ depending on each FA Center. Please ask your local FA center for details.

4. Exclusion of responsibility for compensation against loss of opportunity, secondary loss, etc.

Whether under or after the term of warranty, we assume no responsibility for any damages arisen from causes for which we are not responsible, any losses of opportunity and/or profit incurred by you due to a failure of the Product, any damages, secondary damages or compensation for accidents arisen under a specific circumstance that are foreseen or unforeseen by our company, any damages to products other than the Product, and also compensation for any replacement work, readjustment, start-up test run of local machines and the Product and any other operations conducted by you.

5. Change of Product specifications

Specifications listed in our catalogs, manuals or technical documents may be changed without notice.

6. Application and use of the Product

- (1) For the use of our General-Purpose AC Servo, its applications should be those that may not result in a serious damage even if any failure or malfunction occurs in General-Purpose AC Servo, and a backup or fail-safe function should operate on an external system to General-Purpose AC Servo when any failure or malfunction occurs.
- (2) Our General-Purpose AC Servo is designed and manufactured as a general purpose product for use at general industries. Therefore, applications substantially influential on the public interest for such as atomic power plants and other power plants of electric power companies, and also which require a special quality assurance system, including applications for railway companies and government or public offices are not recommended, and we assume no responsibility for any failure caused by these applications when used.
In addition, applications which may be substantially influential to human lives or properties for such as airlines, medical treatments, railway service, incineration and fuel systems, man-operated material handling equipment, entertainment machines, safety machines, etc. are not recommended, and we assume no responsibility for any failure caused by these applications when used.
We will review the acceptability of the abovementioned applications, if you agree not to require a specific quality for a specific application. Please contact us for consultation.

MODEL	
MODEL CODE	



HEAD OFFICE : TOKYO BLDG MARUNOUCHI TOKYO 100-8310